

**SERVICE MANUAL  
&  
PARTS LIST**

**MODEL: MB-4S**

# CONTENTS

Replacing the Spool Stand .....	4
Replacing the Tension Unit Cover.....	4
Replacing the Static head cover (Right) .....	5
To Replace Right Cover and Left Cover .....	6
Replacing the Base Cover and Bed Cover .....	7
Checking the Thread Paths (1) .....	8
Checking the Thread Paths (2) .....	9
Replacing the Needle .....	10
Needle and Thread Reference Table .....	11
Adjusting the Bobbin Thread Tension .....	12
Checking the Lowest Position of the Needle .....	13
Replacing the Needle Bar Rest .....	14
Replacing the Take-up Lever Cam Roller .....	15
Adjusting the Take up Lever Timing .....	16
Replacing the Presser Foot Cam .....	17-19
Replacing and Adjusting the Presser Foot (1) .....	20
Replacing and Adjusting the Presser Foot (2) .....	21
Replacing the Presser Foot Return Spring and Washer.....	22-24
Replacing the Thread Catcher.....	25
Replacing the Thread Catcher Hook .....	26

# CONTENTS

Replacing the Jump Solenoid.....	27
Adjusting a Play in the Moving Head.....	28
Replacing the Moving Head (1).....	29
Replacing the Moving Head (2).....	30
Adjusting the Needle Drop Position (Back or Forth) .....	31
Adjusting the Needle Height.....	32
Replacing the Needle Bar, Needle Spring and Cushion.....	33
Replacing the Rotation Stopper Plate .....	34
Replacing the Thread Take-up Lever.....	35
Adjusting the Check Spring Tension .....	36
Adjusting the Check Spring Stroke .....	37
Adjusting the Thread Catcher Holder .....	38
Replacing the Thread Catcher Loop Tape .....	39
Replacing the Lateral Moving Unit.....	40
Adjust the Hook Timing.....	41
Adjusting the Position of the Hook Stopper .....	42
Replacing the Thread Cutter Driving Roller.....	43
Replacing the Dynamic Cutter Blade.....	44
Replacing the Static Cutter Blade.....	45
Adjusting the Static Cutter Blade.....	46

# CONTENTS

Adjusting the Dynamic Cutter Blade.....	47
Adjusting the Bobbin Thread Holder.....	48
Adjusting the Thread Keeper .....	49
Adjusting the X-carriage Belt Tension.....	50
Replacing the X-carriage Belt.....	51
Adjusting the Y-carriage Belt Tension.....	52
Replacing the Y-carriage Belt.....	53
Adjusting the Timing Belt Tension .....	54
Replacing the Timing Belt.....	55
Adjusting the Motor Belt Tension .....	56
Replacing the Motor Belt .....	57
Replacing the DC Motor .....	58
To Reset Motor Drive Time .....	59
Adjusting the Needle Upper Shaft Timing.....	60
Adjusting the Moving Head Stop Position.....	61
Adjusting the Needle Stop Position .....	62
Adjusting the Carriage Home Position.....	63
PARTS LIST .....	64-108



## Replacing the Spool Stand

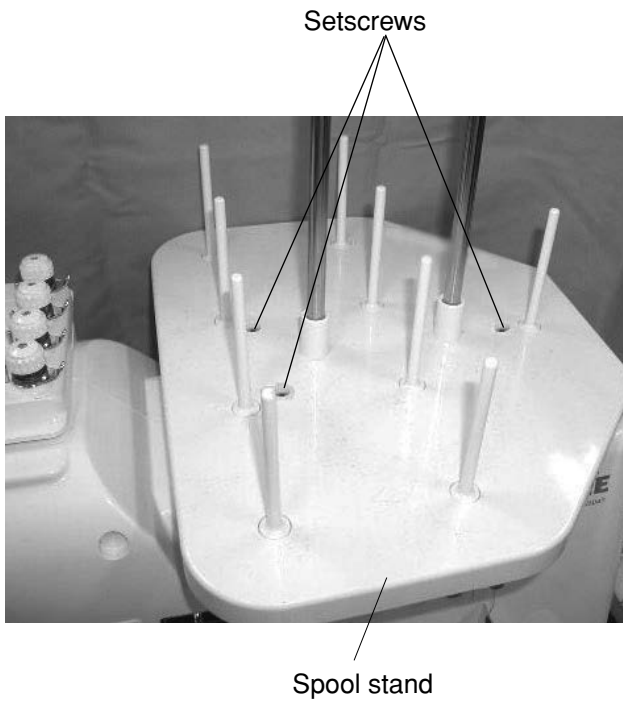

### To remove:

1. Remove the setscrews and spool stand.

### To attach:

2. Attach the spool stand and tighten the setscrews.

## Replacing the Tension Unit Cover

Tension unit cover

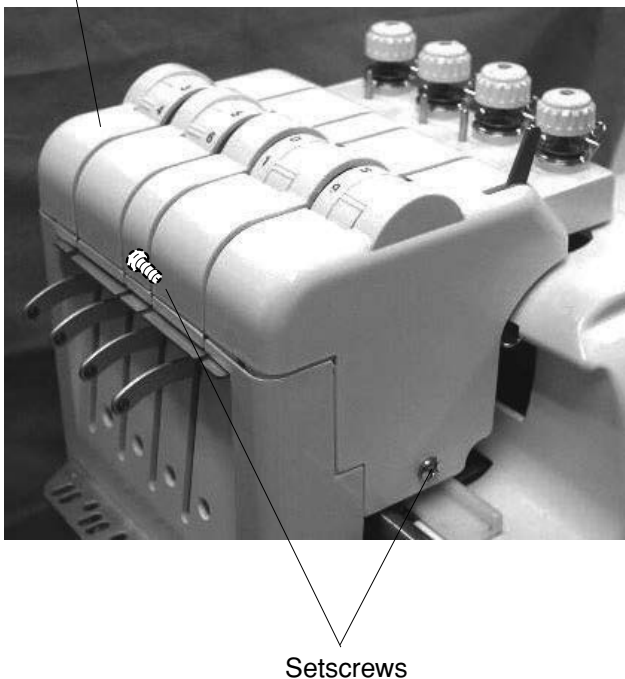

### To remove:

1. Remove the setscrews and tension unit cover.

### To attach:

2. Attach the tension unit cover and tighten the setscrews.

# Replacing the Static Head Cover (Right)

Caps      Setscrews (A)



RCS mounting arm knob



LED lamp connector

Hooks

K-board connector



## To remove:

1. Loosen the RCS mounting arm knob and remove it.
2. Remove caps, and two setscrews (A). Remove the static head cover (right).
3. Disconnect the LED lamp connector and K-board connector.

## To attach:

4. Connect the LED lamp connector and K-board connector.
5. Attach the static head cover (right) with the two setscrews (A). Attach the caps.
6. Attach the RCS mounting arm knob.

# To Replace Right Cover and Left Cover

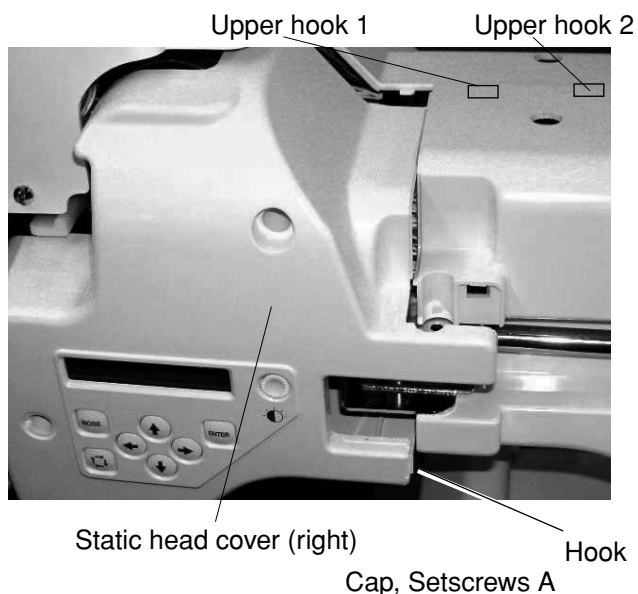

## Right Cover

### To remove:

1. Remove head cover (right).  
Unhook the right cover from the right hook.
  - To remove the head cover, Unhook the cover from upper hook 1, upper hook 2 and the hook on handwheel side.
2. Remove caps and setscrews A.  
Remove the right cover.

### To attach:

3. Attach right cover with setscrews A and caps.
4. Attach the head cover (right).
  - Do not bind cords when attaching the head cover (right).

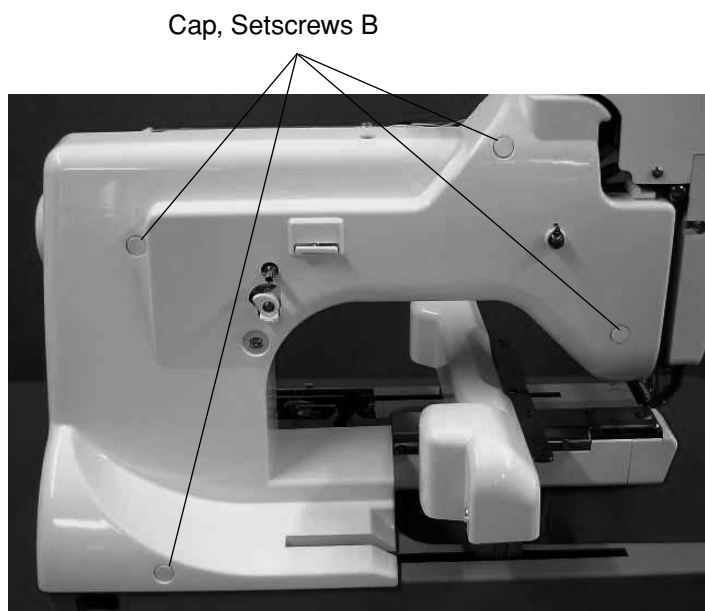

## Left Cover

### To remove:

1. Remove caps and setscrews B.  
Remove the left cover.

### To attach:

2. Attach left cover with setscrews B and caps.

# Replacing the Base Cover and Bed Cover

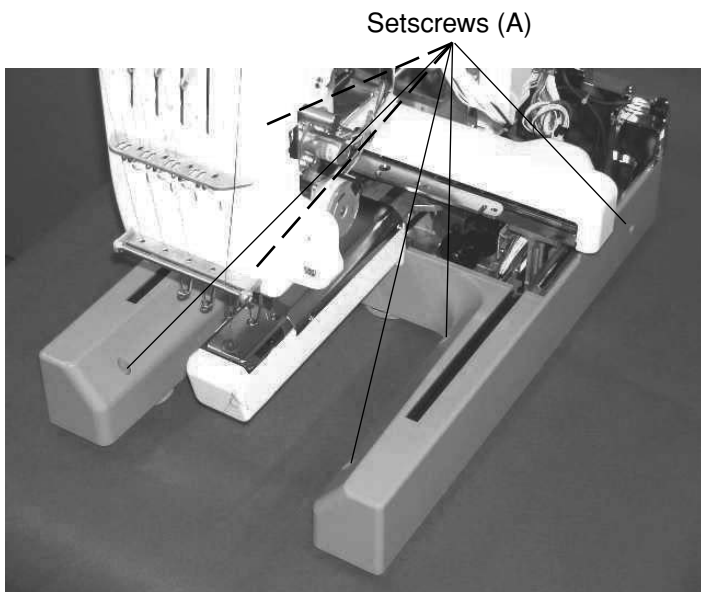

## Base Cover

### To remove:

1. Remove the six setscrews (A).
2. Lift the back of the machine and remove it from the base cover.

### To attach:

3. Attach the machine into the base cover.
4. Tighten the six setscrews (A) securely.

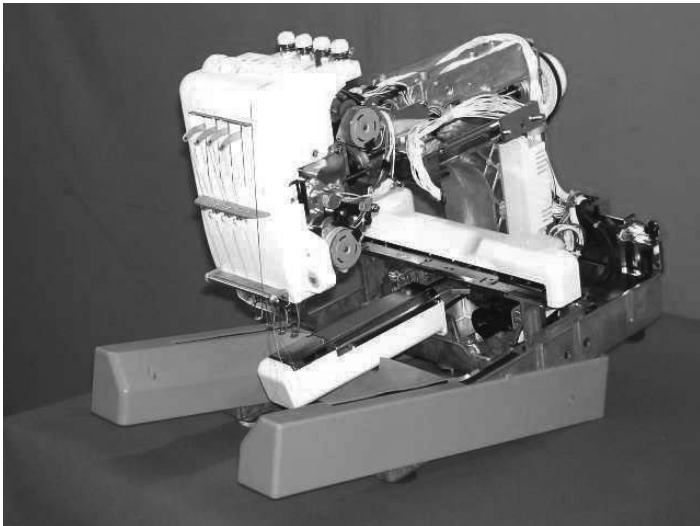

## Bed Cover

### To remove:

1. Remove the setscrew A. Remove the bed cover.

### To attach:

2. Attach the bed cover with the setscrew A.

Setscrew A

# Checking the Thread Paths (1)



Detecting roller

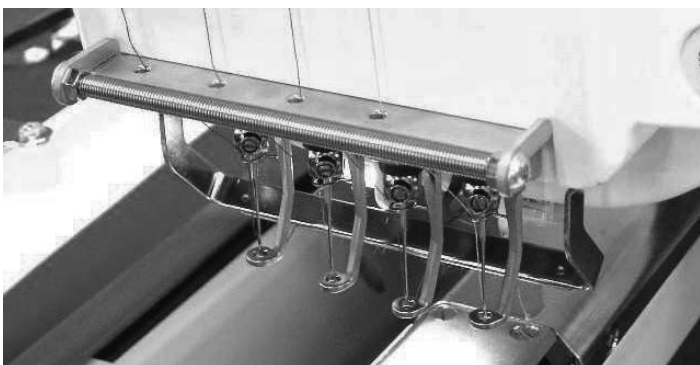

To avoid seam puckering, skipped stitches or thread breaking, keep the thread paths in the best condition.

1. Tension control, detecting roller
  - a) Detecting rollers should spin smoothly.
  - b) Tension controls and detecting rollers should be free of lint or dust.

2. Thread guide hole
  - a) There should be no burrs or scratches.

3. Thread take-up lever
  - a) There should be no burrs or scratches.

4. Lower guide plate
  - a) There should be no burrs or scratches.

5. Needle
  - a) The needle should not be bent or blunt.

## To check the needle:

Touch the tip of the needle and slide it over on your nail and slid it lightly.

The needle must be blunt if there is any scratch on your nail after sliding the needle on your nail.

In that case, replace the needle.

Place the flat side of the needle onto something flat (needle plate, glass, etc.). The gap (A) between the needle and the flat surface should be consistent. Replace the needle if the gap is not consistent.

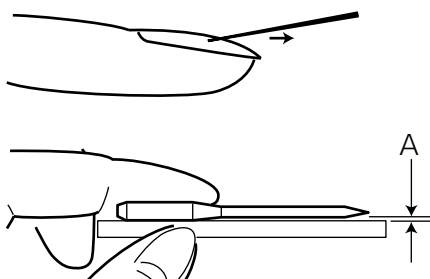

## Checking the Thread Paths (2)

Upper side

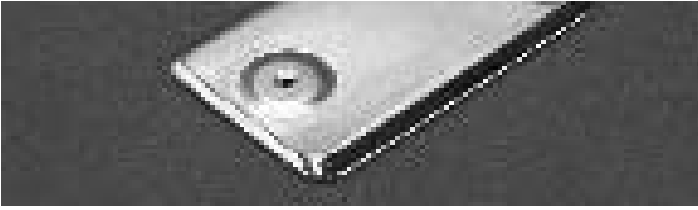

6. Needle plate
  - a) There should be burrs or scratches.

Lower side



7. Presser foot
  - a) There should be no burrs or scratches, especially inside of the presser foot hole.
  - b) There should be no warp in the presser foot.

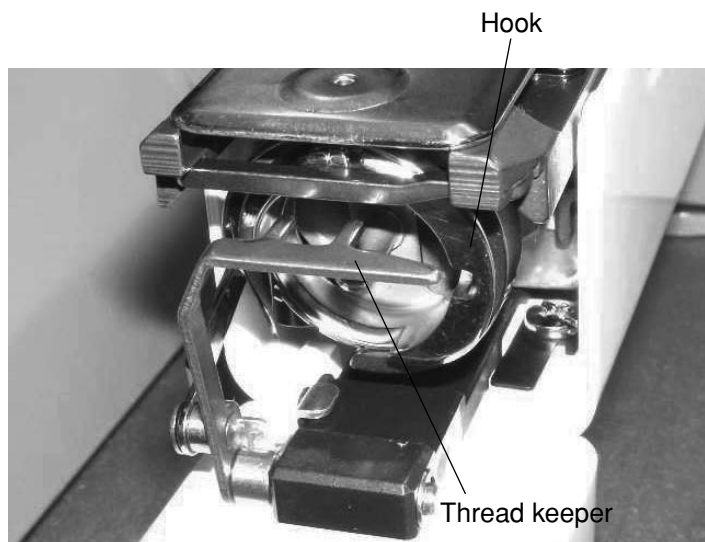

8. Hook race
  - a) There should be no burrs or scratches.
  - b) The tip of hook race should not be blunt.
  - c) There should be no detectable play in the hook and hook race.
9. Thread keeper
  - a) There should be burrs or scratches, especially on the tip of the thread keeper.



10. Check spring
  - a) The check spring should not be worn.

# Replacing the Needle

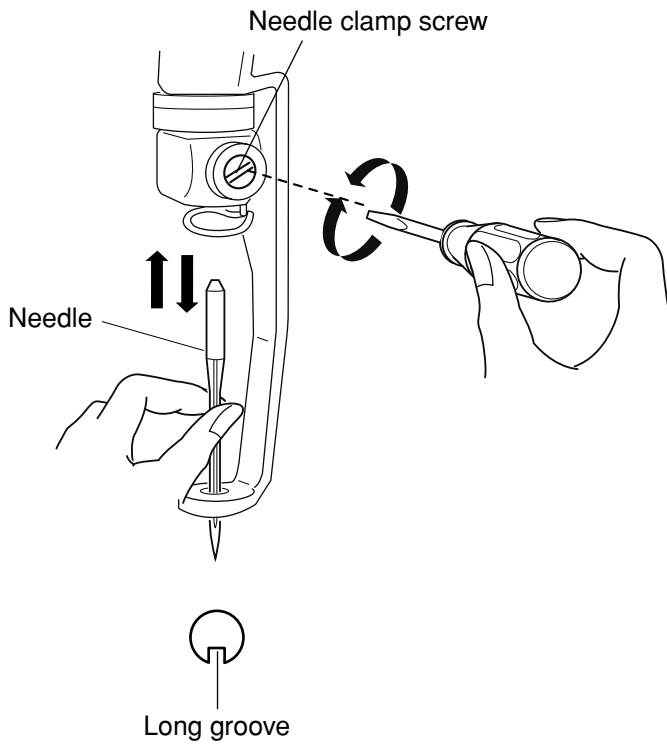

## To remove:

1. Loosen the needle clamp screw.
2. Remove the needle.

## To attach:

3. Insert the needle into the needle clamp with the long groove facing you. Push the needle up as far as it will go.
4. Tighten the needle clamp screw.

## Needle and Thread Reference Table

Use DBxK5Q1NY needles and select an appropriate size of needle for threads and fabrics to be sewn.

An inappropriate size of needle may cause skip stitches, thread breakage or loose seam.

Please refer to the table below and select the suitable needle size.

Thread Size (Denier) Polyester	Needle Size
75	8~10
120	9~11
200	11~14



# Adjusting the Bobbin Thread Tension

1

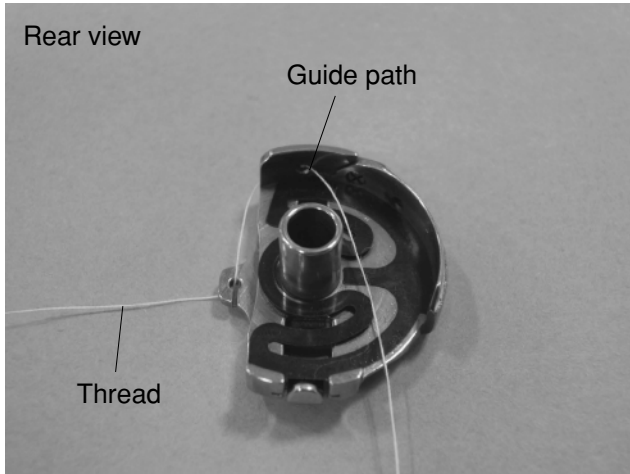

\* Use cotton thread size 120.

1. Guide the thread to the left to pass it into the guide path as shown.

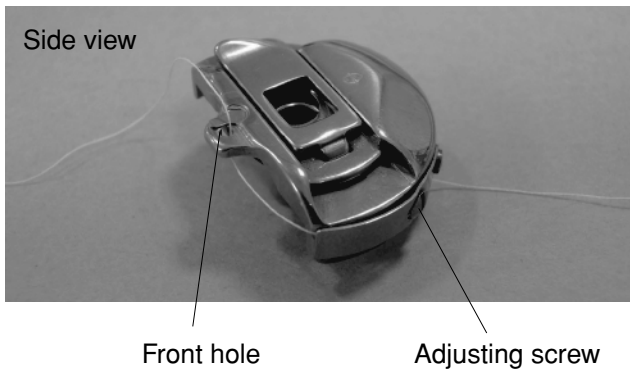

2

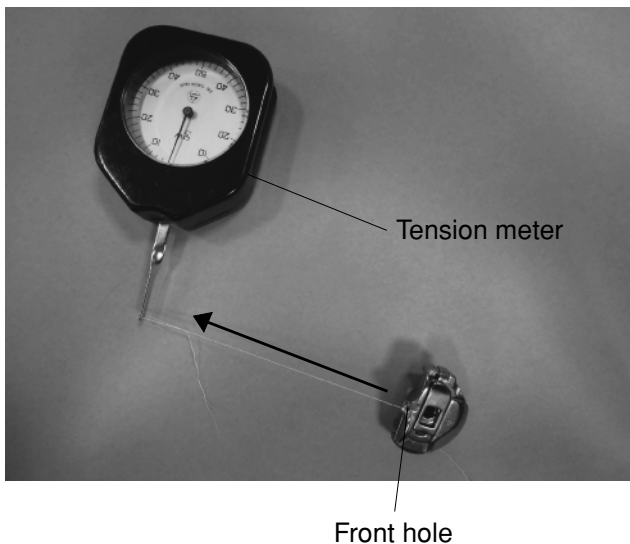

2. Pulling the thread from the front hole in the direction of arrow, measure the thread tension with a tension meter.  
The thread tension should be in the range of 20 - 30gf.  
If not, adjust the thread tension by turning the adjusting screw.

## Checking the Lowest Position of the Needle

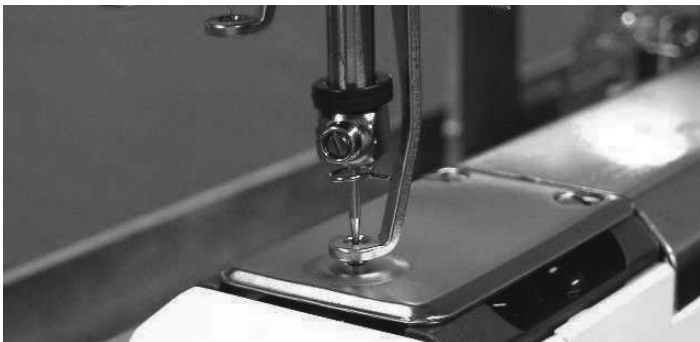
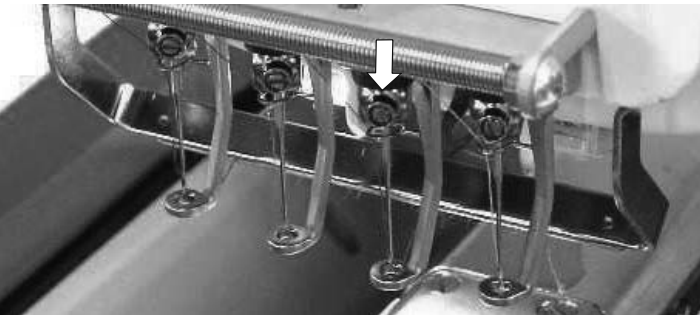
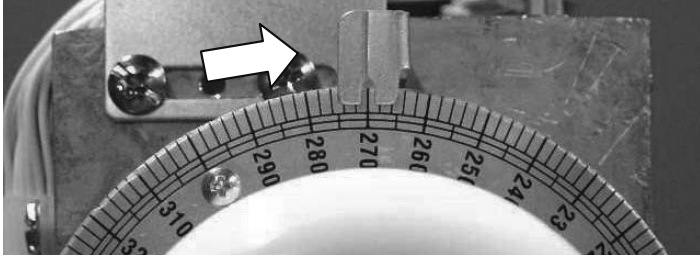

1. Remove the spool stand, static head right cover and left cover.

2. Turn the handwheel to set the index disk at 270°.

3. Push the needle bar down to engage the needle bar clutch.

4. Turn the handwheel to set the needle bar at its lowest position.  
Use a lever type dial indicator to measure the needle bar height.

5. Turn the handwheel clockwise until the indicator reads 0.2 mm and read the angle (A°) of the index disk.  
Turn the handwheel counterclockwise until the indicator reads 0.2 mm and read the angle (B°) of the index disk.

Calculate the mean angle (C°):  $C = (A + B - 360) \div 2$

Turn the handwheel clockwise to set the index disk at C°.

Loosen the two setscrews and set the pointer at 0° (L).  
Tighten the two setscrews securely.

Check the following items if you have adjusted the lowest position of the needle.

- Upper shaft timing
- Take-up lever timing
- Hook timing
- Thread cutter timing

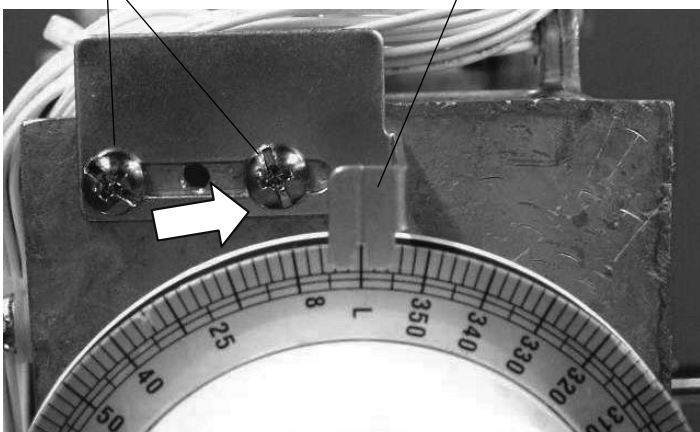
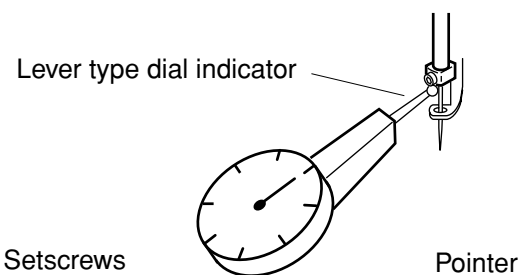

# Replacing the Needle Bar Rest

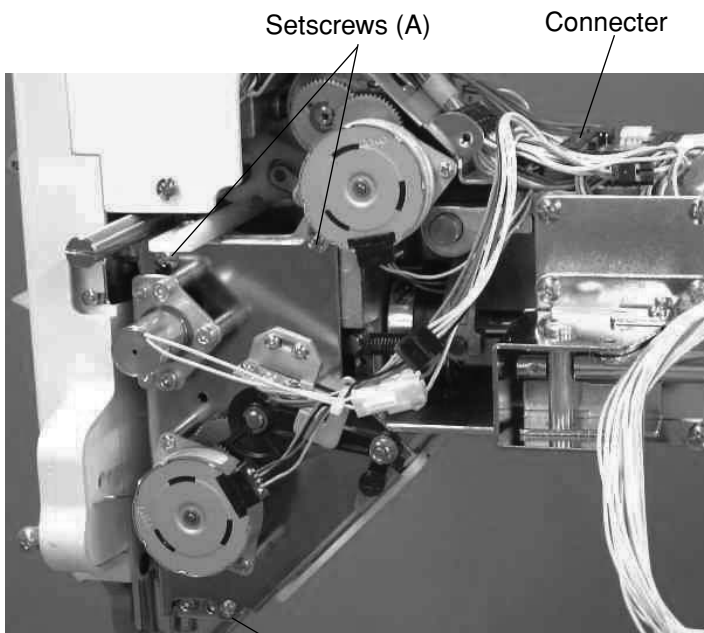

## To remove:

1. Remove spool stand, head cover (right), right cover and left cover.
2. Disconnect the thread catcher unit connector. Remove the two setscrews (A) and setscrew (B). Remove the thread catcher unit.

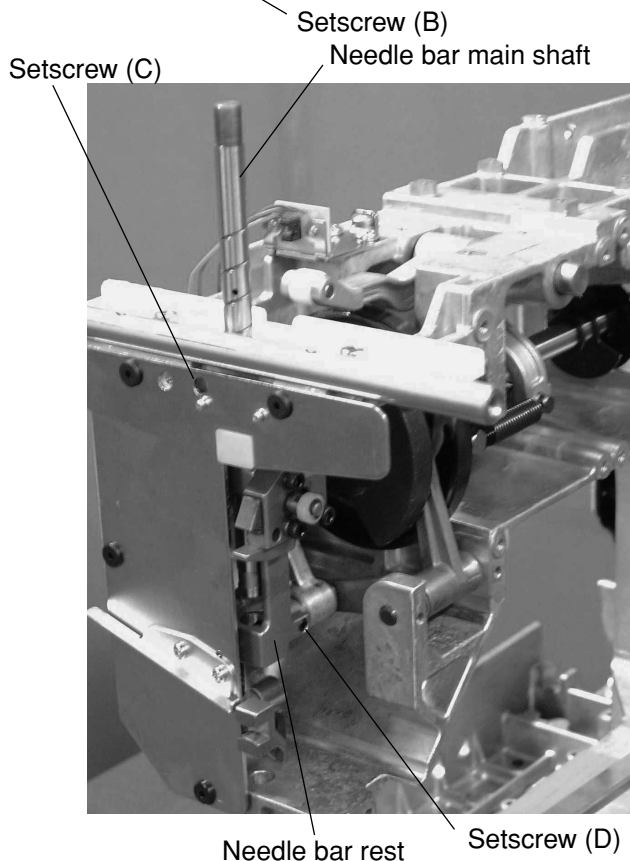

3. Loosen the setscrew (C). Pull the needle bar main shaft up and remove it from the machine.

4. Loosen the setscrew (D) and remove the needle bar rest from the needle bar main shaft.

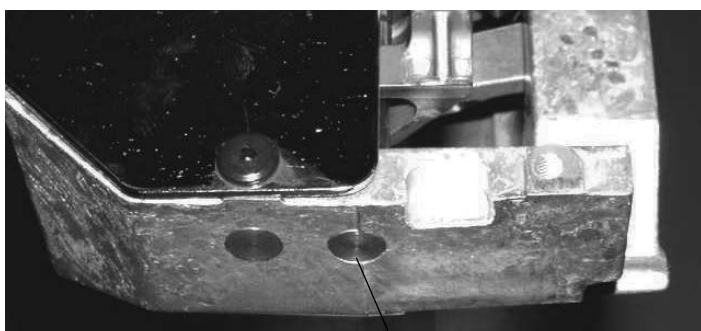

## To attach:

5. Reverse the procedure above. Attach the needle bar main shaft so its bottom end is level with the bottom surface of the head frame.
6. Adjust the needle height after the replacement.

# Replacing the Take-up Lever Cam Roller

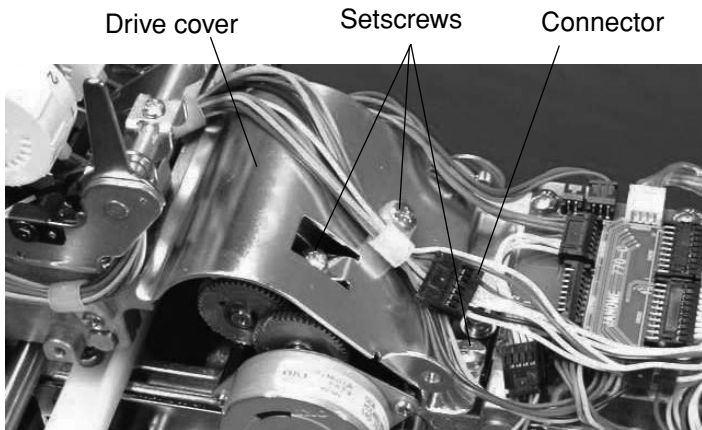

## To remove:

1. Remove spool stand, head cover (right), right cover, left cover and thread tension panel.
2. Remove the three setscrews and drive cover.



3. Remove the thread take-up lever spring with pliers.

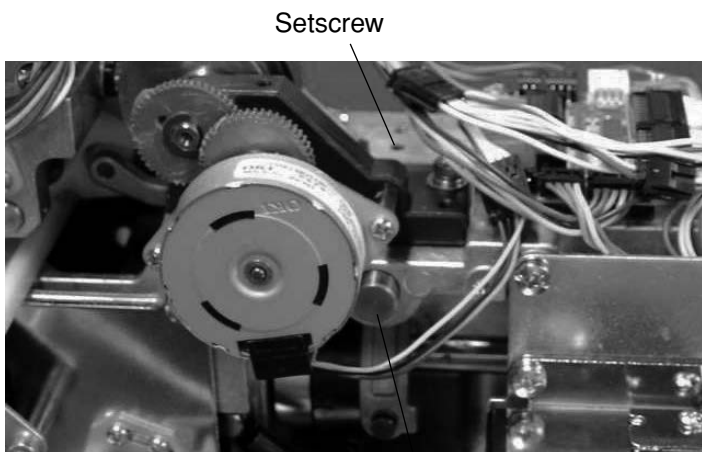

4. Loosen the setscrew. Remove the thread take-up lever shaft, thread take-up lever unit and washer.

Thread take-up lever shaft    Thread take-up lever shaft    Thread take-up lever unit

5. Loosen the setscrew. Remove the cam roller shaft and cam roller.



## To attach:

6. Reverse the procedure above. When attaching the thread take-up lever shaft, tighten the screw while pressing the thread take-up lever shaft lightly.

# Adjusting the Take-up Lever Timing

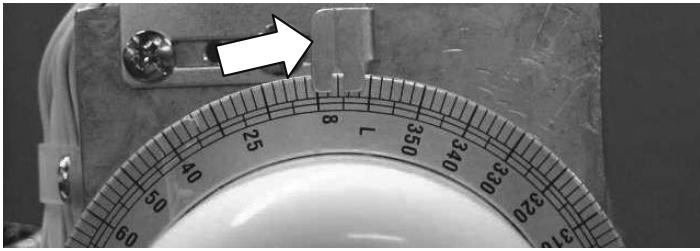

## To remove:

1. Remove spool stand, head cover (right), right cover and left cover.
2. Turn the handwheel to set the index disk at 6°.
3. Insert the positioning pin from the left side of the arm. The positioning pin goes into the pin groove of take-up lever cam if the timing is correctly adjusted.

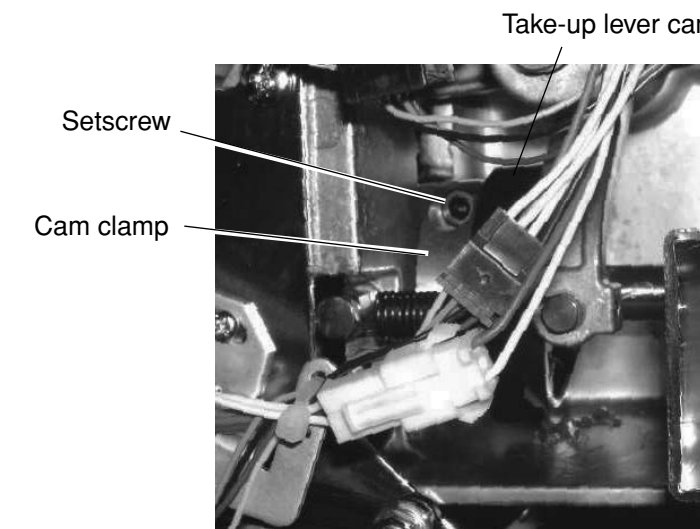
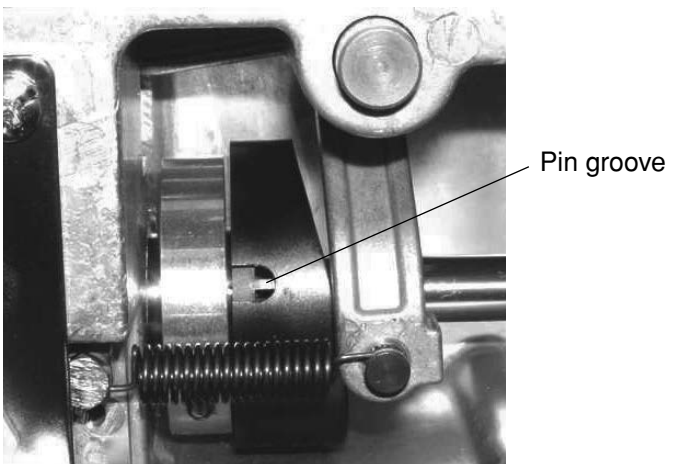

4. If the timing is incorrect, loosen the setscrew on the cam clamp and turn the take-up lever cam so the positioning pin can go into the pin groove on the cam. Turn the handwheel to set the index disk at 6°. Tighten the setscrew on the cam clamp while pressing the take-up lever cam to the side of the dynamic head. There should be no gap between the take-up lever cam and cam clamp.
5. Pull the positioning pin out from the arm. Turn the handwheel to set the index disk at 270°. Attach the removed parts.

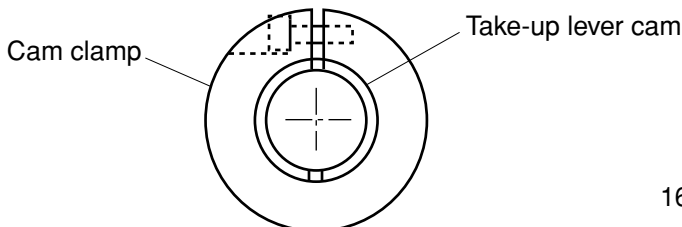

# Replacing the Presser Foot Cam (1)

\*The presser foot cam shall be replaced as the crank unit.

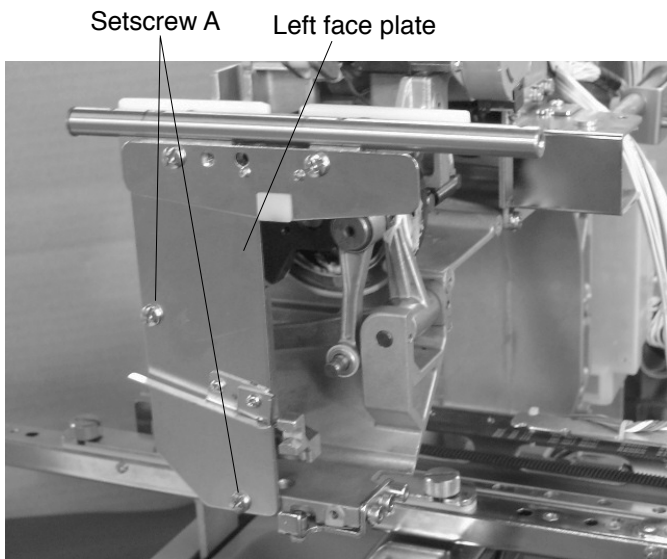

1 Remove the spool stand, head set right cover, right cover, left cover, moving head, thread catcher (unit) and needle bar rest.

\* The lateral moving unit is not needed to remove.

2 Remove the setscrews A (2 pcs.) and the left face plate.

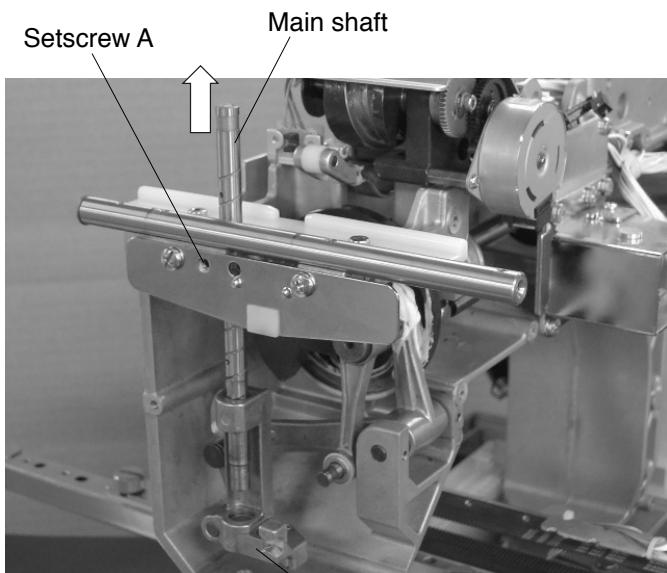

3 Loosen the setscrew A. Pull the main shaft up. Remove the presser foot block (unit).

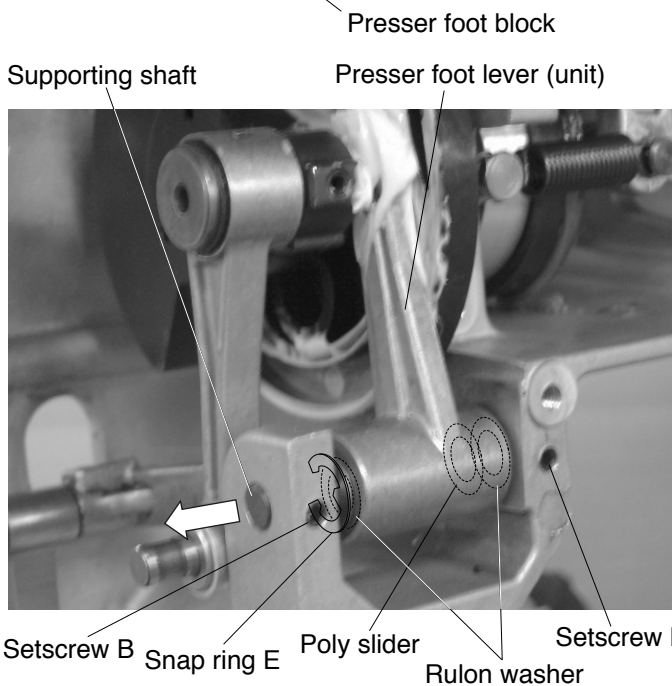

4 Remove the snap ring E. Loosen the setscrews B (2 pcs.). Push the supporting shaft from the backside and pull the supporting shaft out to the front. Remove the presser foot lever (unit), poly slider and Rulon washer.

## Replacing the Presser Foot Cam (2)

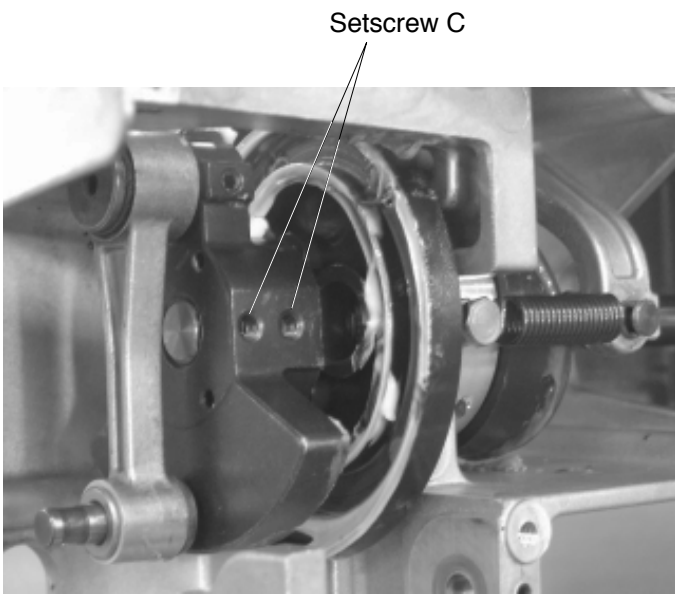

5 Loosen the setscrews C (2 pcs.).

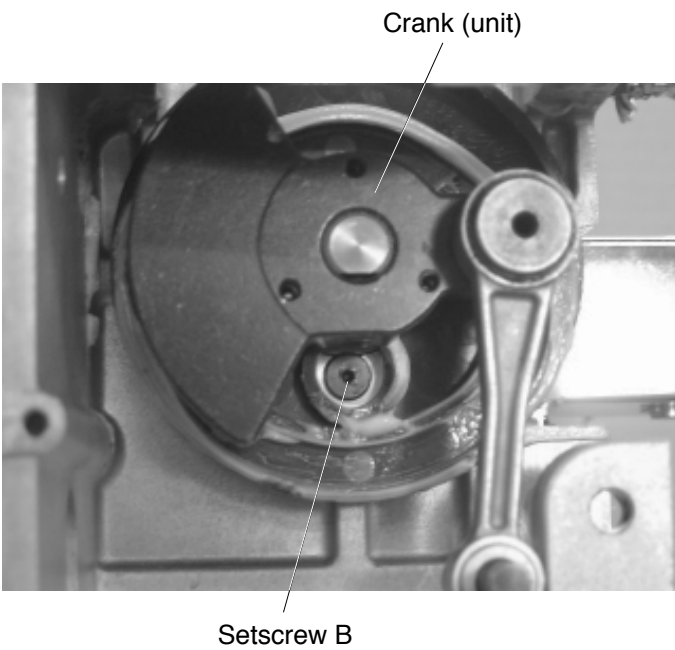

6 Remove the setscrew B.  
Pull the crank out to the front to remove it.

## Replacing the Presser Foot Cam (3)



- 7 Apply the grease to the groove of the presser foot cam.  
\* Recommended grease: MOLYKOTE (R) EM-30L.
- 8 Reverse the procedure to reinstall the parts.  
Do not attach the covers yet.
- 9 Check the lowest position of the needle (refer to page 13 of service manual).
- 10 Adjust the position of the lateral moving unit (refer to page 40 of service manual).
- 11 Attach the covers according to the procedures.



# Replacing and Adjusting the Presser Foot (1)

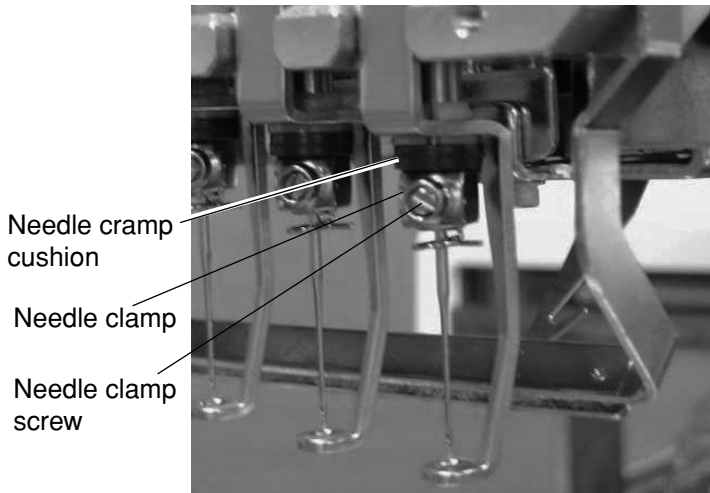

1. Remove the lower thread guide plate unit and thread catcher panel.
2. Loosen the needle clamp screw and the setscrew. Remove the needle, needle clamp and two needle clamp cushions.

**NOTE:**

The presser foot will spring down when the needle clamp is removed.

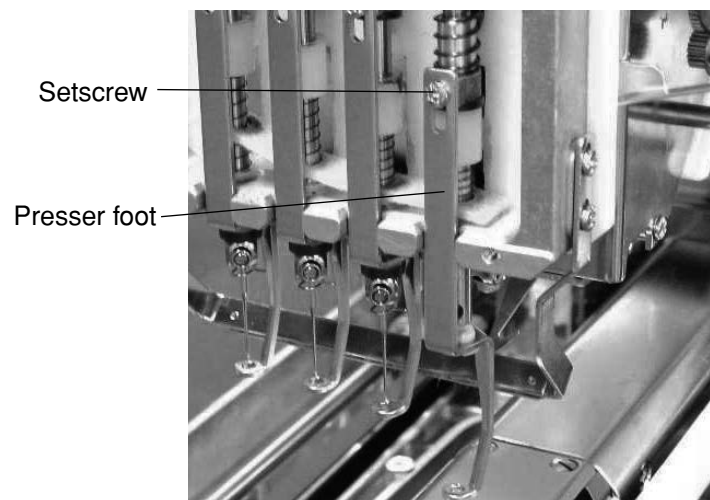
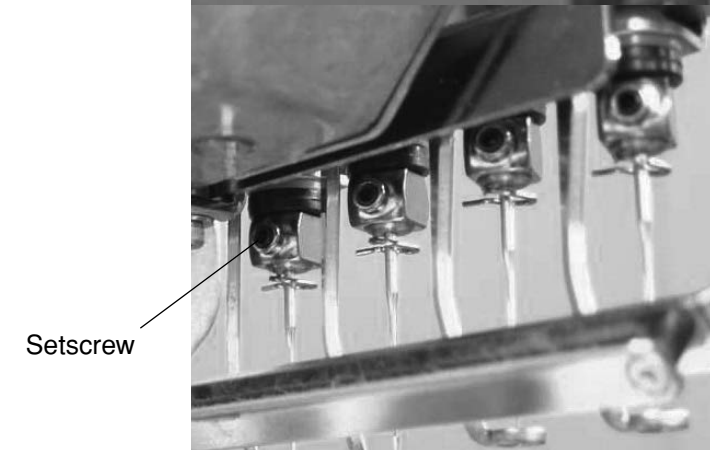

3. Remove the setscrew and replace the presser foot.
4. Attach the needle, needle clamp and needle clamp cushions. Tighten the needle clamp screw and setscrew.
5. Adjust the needle height. (see To Adjust the Needle Height)

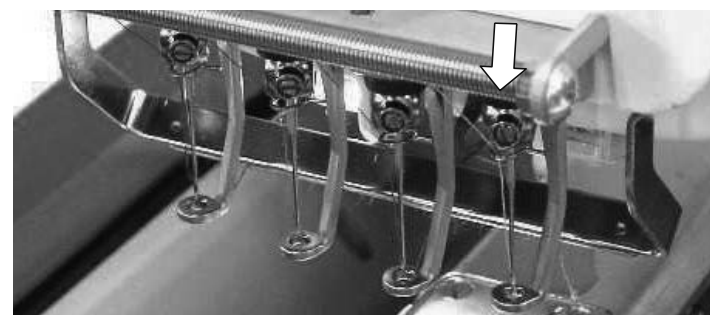

6. Push the needle bar down to engage the needle bar clutch.

## Replacing and Adjusting the Presser Foot (2)

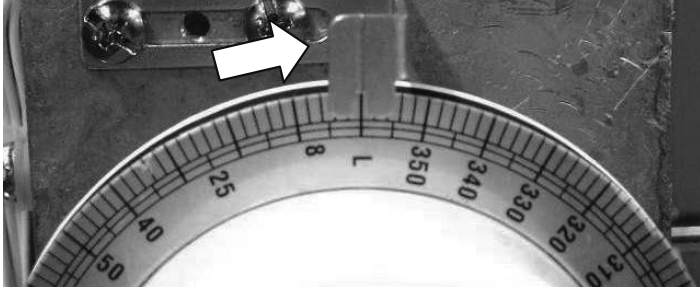

7. Turn the handwheel to set the index disk at 0° (L).



8. Insert the 1.2 mm thick gauge between the needle plate and the presser foot.

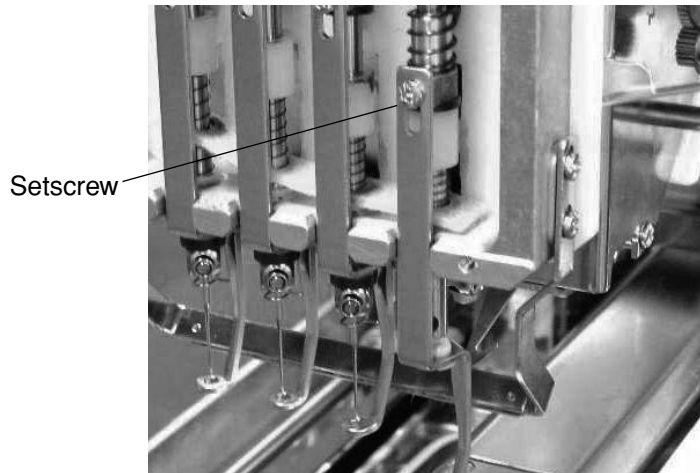

9. Tighten the setscrew.

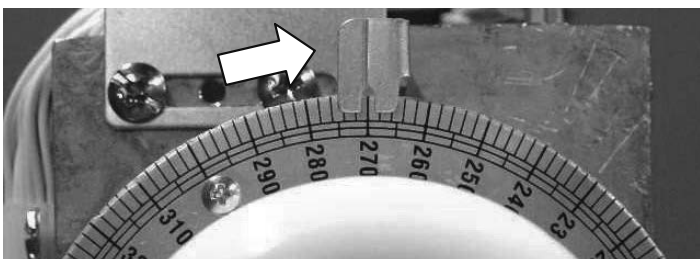

10. Turn the handwheel to reset the index disk at 270°.

11. Attach the removed parts.

# Replacing the Presser Foot Return Spring and Washer

## Step 1: Open the Needle Change Adjusting Window of the Factory Adjusting Mode.

Select needle bar No. 1.

## Step 2: Removing the Needle Bar

- 1 Remove the tension unit cover, lower thread guide plate and thread catcher panel (head cover).
- 2 Remove the 2 setscrews (A) and the tension control unit.
- 3 Loosen the needle clamp screw and remove the needle.
- 4 Lower the needle bar. Loosen the hexagonal socket screw and remove the needle clamp.
- 5 Remove the setscrew (B), presser foot and cushion.

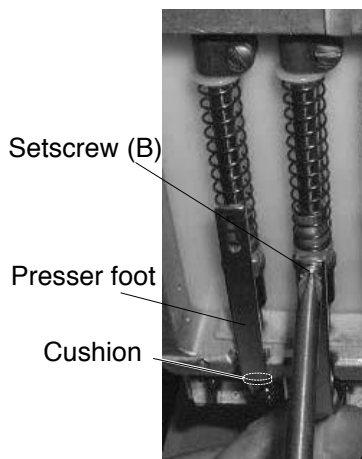
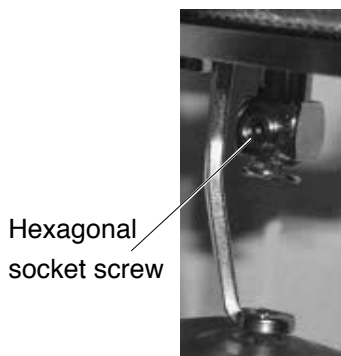
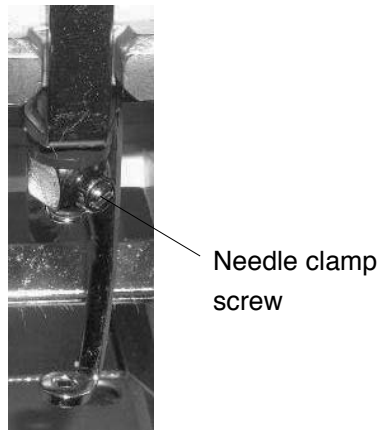
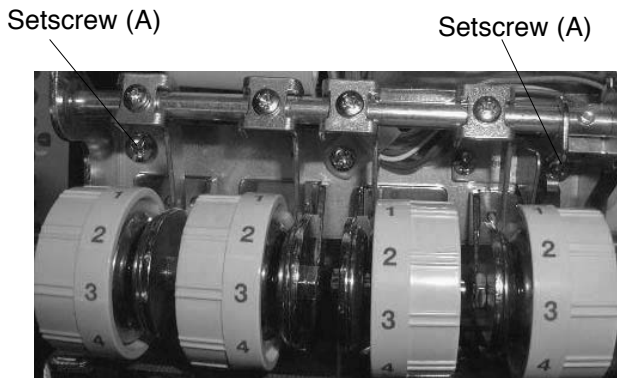

Needle bar holder screw



Presser foot holder

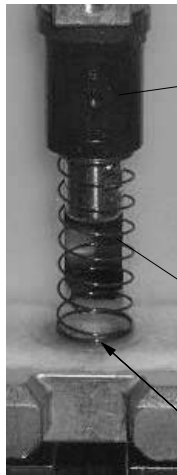

Presser foot return spring

Place the washer here.

- Loosen the needle bar holder screw.  
Pull the needle bar up until the bottom end of the needle bar reaches the bottom end of the presser foot holder.

**Note:** Do not pull the needle bar out of the frame.

- Replace the white plastic washer with the metal washer. Replace the foot return spring with the new spring (closed end coil).



Setscrew (B)

Presser foot

- Attach the presser foot to the presser foot block with the setscrew (B).

Tighten the setscrew (B) loosely.

Hexagonal socket screw

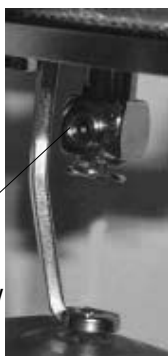

Upper hole

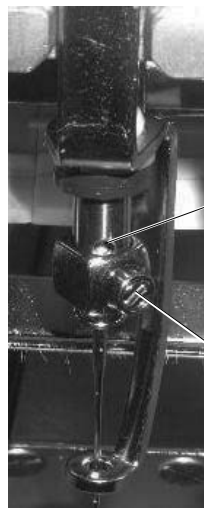

Needle clamp screw

- Attach the cushion and needle clamp to the needle bar.
- Turn the needle bar so the upper hole faces front and the lower hole faces 30 degrees right to the front. Screw the needle clamp screw through the needle clamp and into the lower hole in the needle bar. Insert the needle with the long groove facing front (in line with the upper hole).

- Tighten the needle clamp screw lightly while pressing the needle clamp down.

Turn the hand wheel to lower the needle bar at its lowest position. Hold the needle clamp with your fingers and tighten the hexagonal socket screw securely. Tighten the needle clamp screw securely.

**Note:** The long groove of the needle should face front.

Long groove

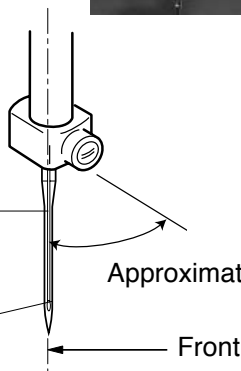

Approximately 30 degrees

Needle eye

Front

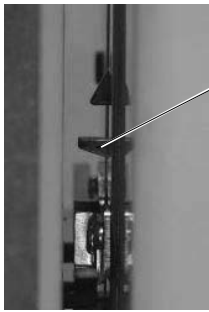

Needle rest (view from the side of the moving head)

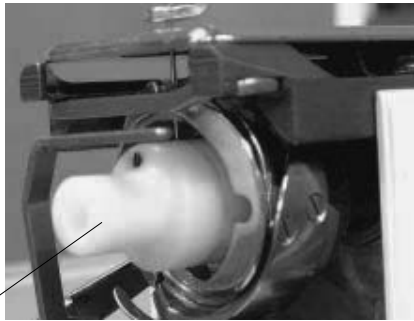

Needle bar height gauge

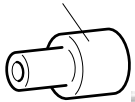

Needle bar holder screw

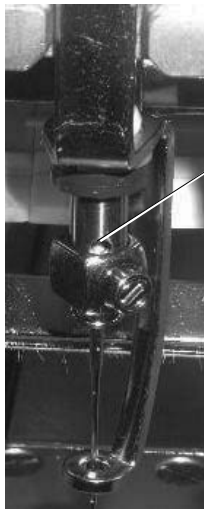

Hole in the needle bar

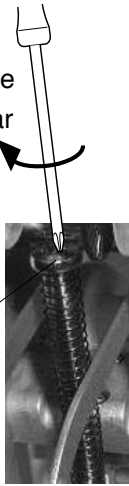

Cap screw



Thickness gauge (1.2 mm)

Setscrew (B)

Presser foot

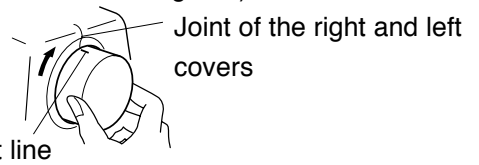
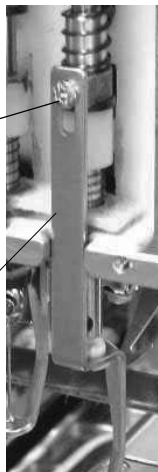

Alignment line

### Step 3: Adjusting the Height of the Needle Bar and Presser Foot

- 12 Remove the bobbin case.
- 13 Hold the needle bar holder and push the needle bar down until it clicks.
- 14 Lower the needle bar to the lowest position by turning the hand wheel.
- 15 Insert the needle bar height gauge into the hook.
- 16 Knock on the top of the needle bar gently until the tip of the needle contact the gauge.  
Turn the gauge to find if the needle reaches the gauge. Set the direction of the needle bar so the hole in the needle bar faces directly the front.
- 17 Tighten the needle bar holder screw securely.  
**Note:** Check if the needle bar is securely fixed by turning the cap screw clockwise.
- 18 Loosen the setscrew (B).
- 19 Insert the 1.2 mm thickness gauge between the presser foot and needle plate. Press the presser foot down against the gauge.
- 20 Tighten the setscrew (B) securely.
- 21 Remove the needle bar height gauge.
- 22 Turn the hand wheel to match the alignment line on it with the joint of the right and left covers (the upper shaft will be set at 270 degrees).

\* To replace the spring and washer on other needle bars, follow the above steps (select the relevant needle bar in the Needle Change adjusting window).

- 23 Attach the tension control unit and thread catcher panel (head cover). Lower thread guide plate and tension unit cover.

**Note:** Be sure not to get wires caught between covers. Adjust the position of the tension unit cover so the arch of the cover aligns with the tension dials.

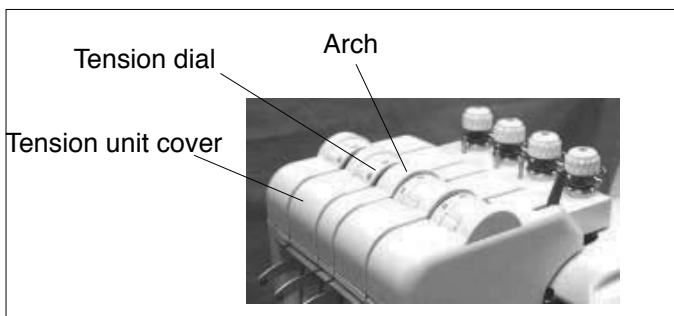

### Step 4: Test Sewing

Insert the test pattern card into the RCS unit and sew the test pattern.

Use a 120 deniers rayon thread or equivalent for needle and a #120 cotton or polyester thread for bobbin.

# Replacing the Thread Catcher

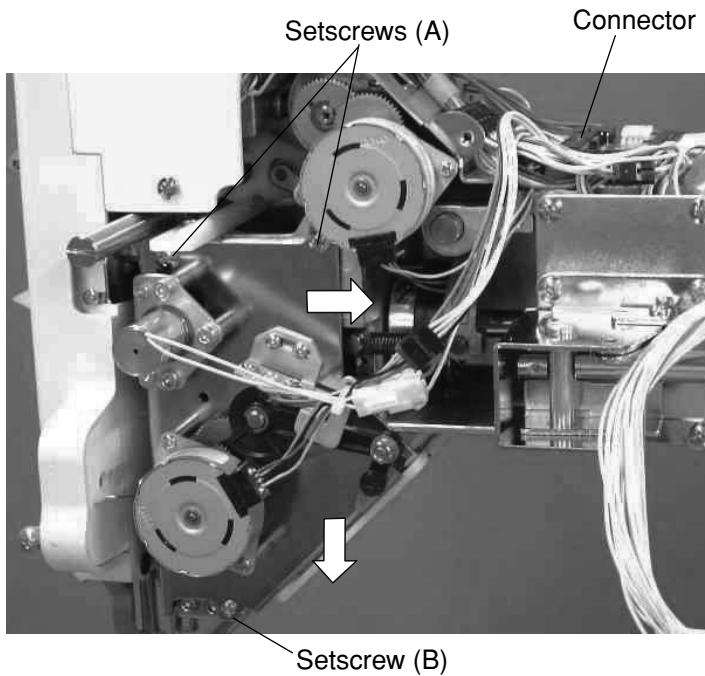

## To remove:

1. Remove spool stand, head cover (right), right cover, left cover, moving head and horizontal moving unit.
2. Disconnect the thread catcher connector. Remove the two setscrews (A), setscrew (B) and the thread catcher.

## To attach:

3. Connect the thread catcher connector. Tighten the setscrews (A) and setscrew (B) while pressing the thread catcher unit in the direction of arrows as illustrated.
4. Adjust the thread catcher (see page 38).
5. Attach removed parts.

# Replacing the Thread Catcher Hook

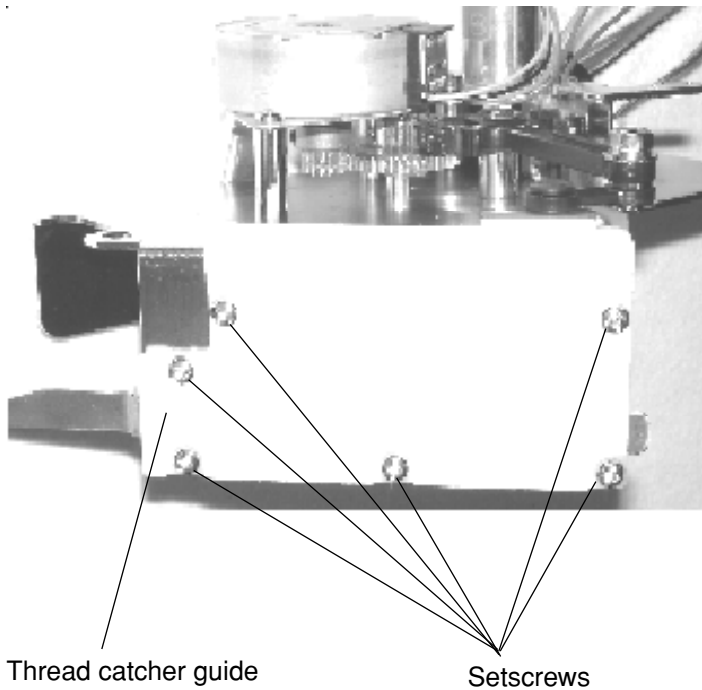

## To remove:

1. Remove the thread catcher unit (see page 25).
2. Loosen the six setscrews and remove the thread catcher guide.
3. Remove the thread catcher hook screw.  
Remove the thread catcher hook.

## To attach:

4. Attach the thread catcher hook with the thread catcher hook screw.
5. Attach the thread catcher guide with the six setscrews.
6. Attach the thread catcher unit (see page 25).

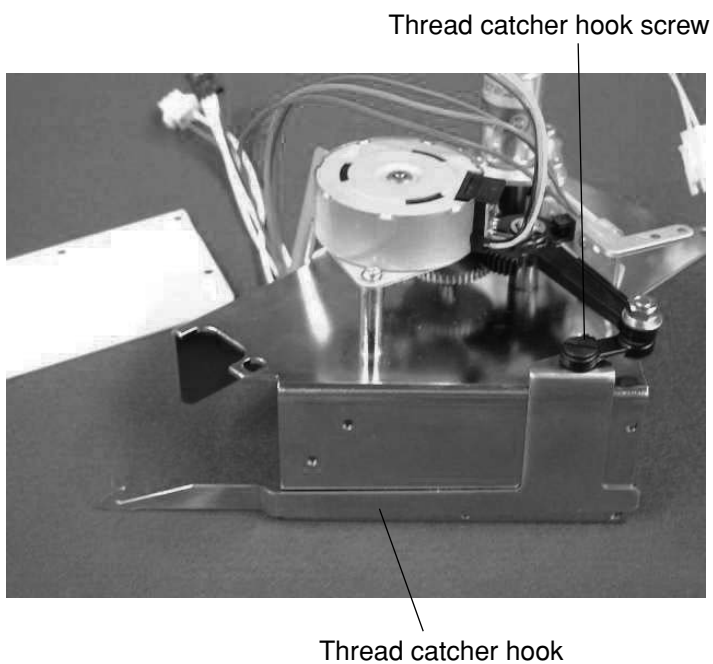

# Replacing the Jump Solenoid

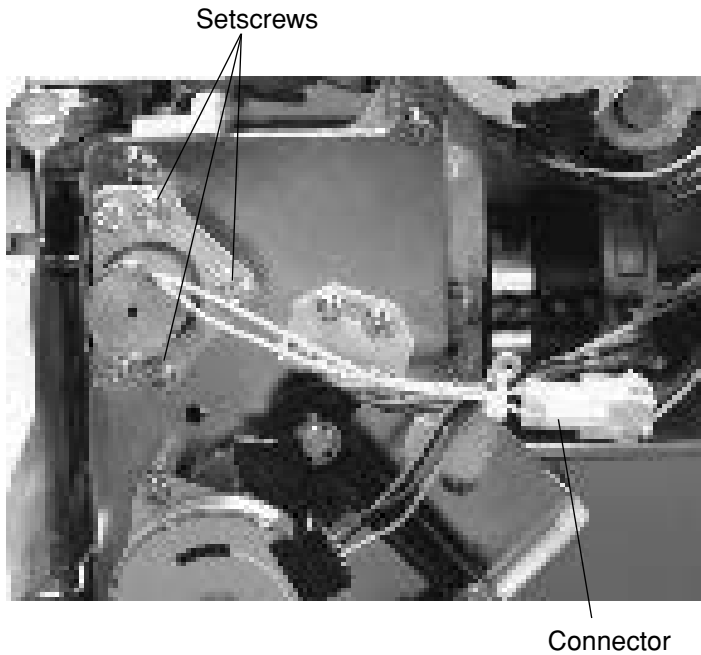

1. Remove the head cover (right).
2. Disconnect the connector. Remove the three setscrews and jump solenoid.

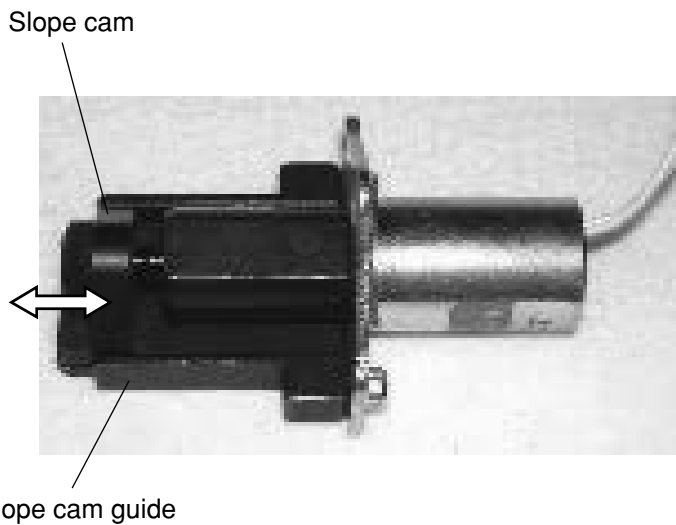

3. The slope cam should slide on the slope cam guide smoothly. Clean the solenoid if there is any lint or dust on it.

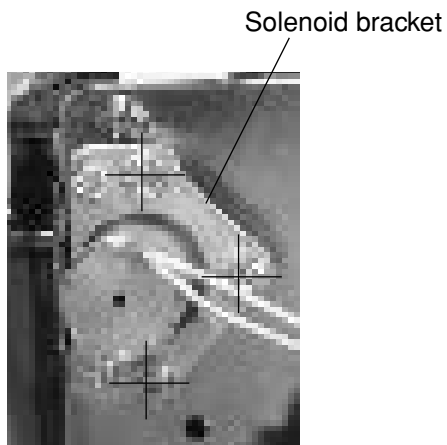

4. Attach the jump solenoid to the machine. Tighten the setscrews. Setscrews should be positioned at center of holes.
5. Attach the head cover (right).



## Adjusting a Play in the Moving Head

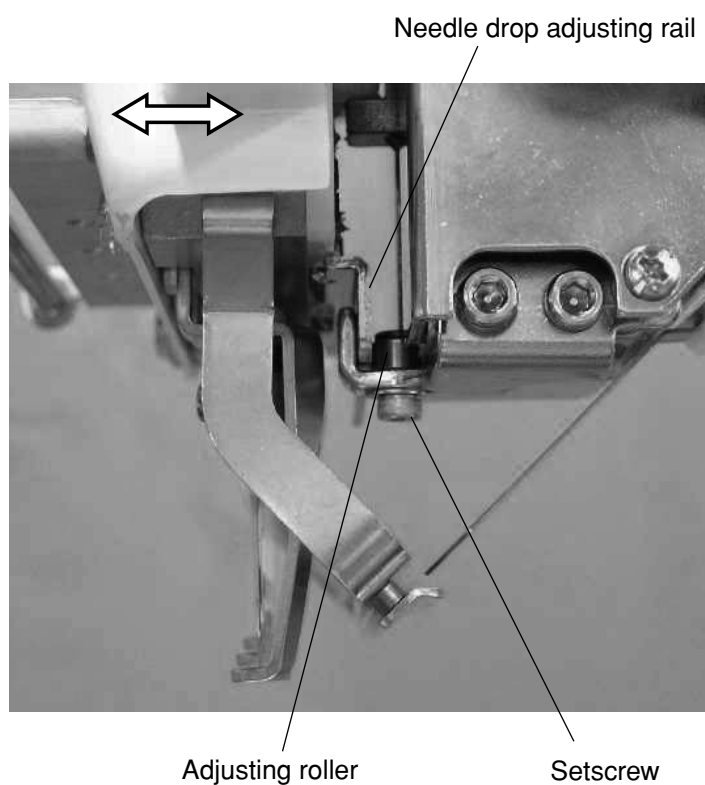

1. Remove head cover (right).
2. Check the play in the direction of the arrows. If there is a detectable play, loosen the setscrew and tighten it while pressing the adjusting roller against the needle drop adjusting rail.
3. Adjust the needle drop position (see page 31).
4. Attach the head cover (right).

# Replacing the Moving Head (1)

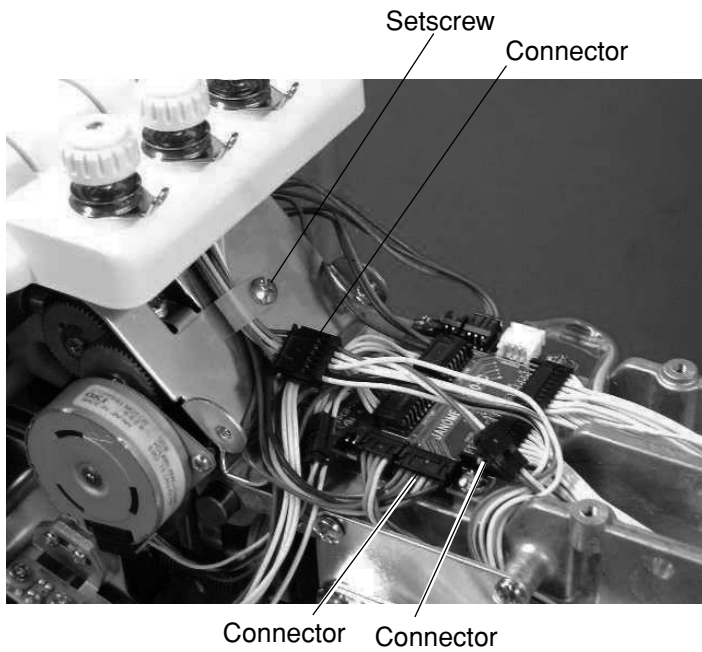

## To remove:

1. Remove the spool stand, head cover (right), right cover and left cover.
2. Disconnect the connectors. Remove the setscrew of the cord clamp.

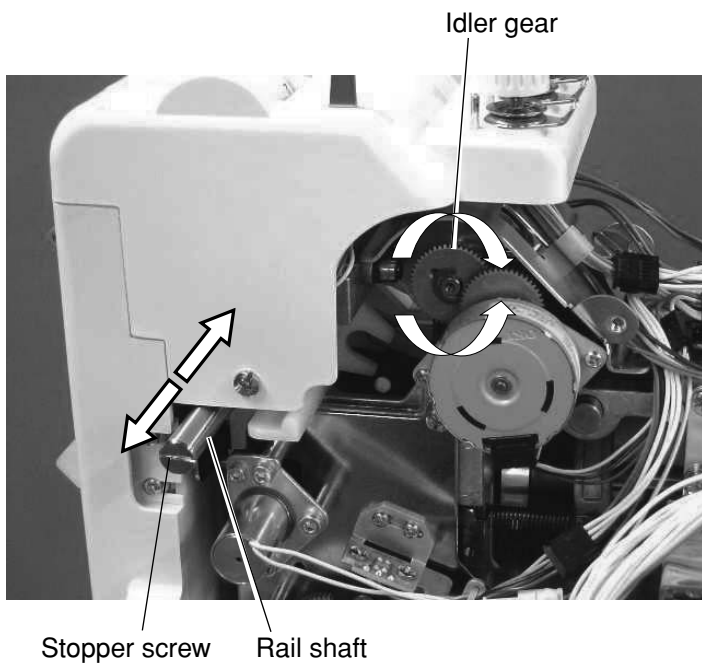

3. Remove either the left or right side of stopper screw on the rail shaft.
4. Turn the idler gear to move the moving head to the end of the rail shaft with the stopper screw removed. Support the moving head securely while removing the moving head so as not to fall.

## To attach:

5. Attach the moving head. Tighten the stopper screw.

## Replacing the Moving Head (2)

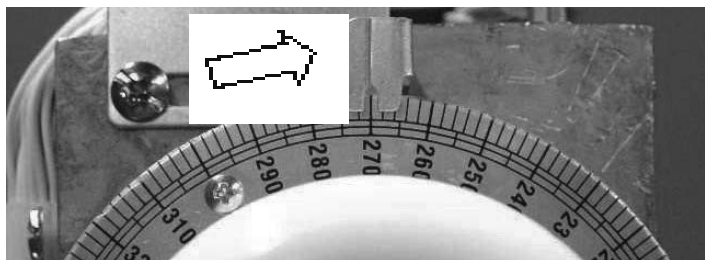

6. Turn the handwheel to set the index disk at 270°.

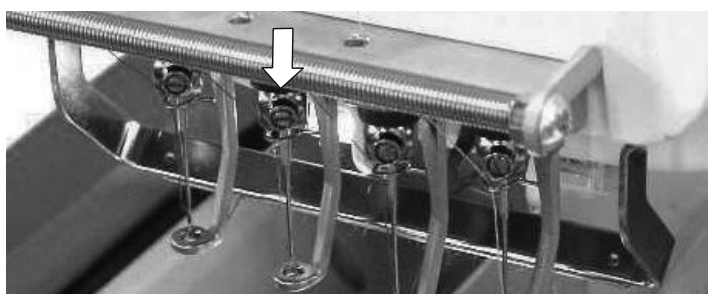

7. Turn the idler gear to set the moving head to the needle bar No. 3.  
Push the needle bar No. 3 down to engage the needle bar clutch.

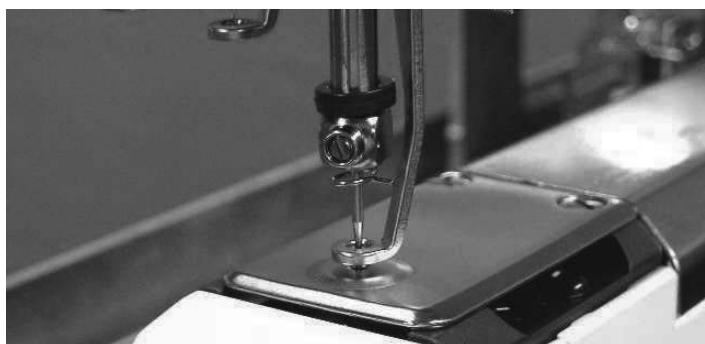

8. Turn the handwheel until the needle goes into the needle hole.

9. Check the needle drop position. The needle drop position should be the center of the needle hole.

If the needle drop position is off position to the front or rear, adjust the needle drop position (see the next page).

If the needle drop position is off position in the lateral direction, adjust the position of the lateral moving head (see page 40).

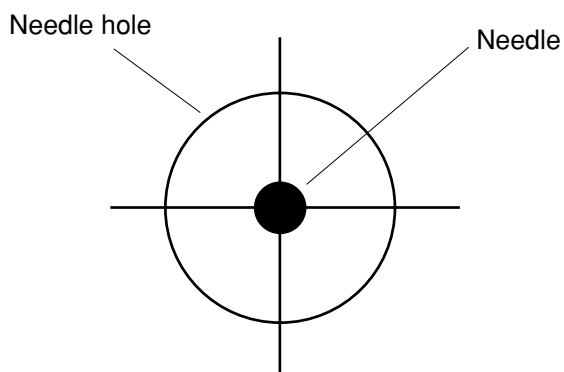

10. Turn the handwheel to set the index disk at 270°

11. Connect the connectors and attach the parts removed.

## Adjusting the Needle Drop Position (Back or Forth)

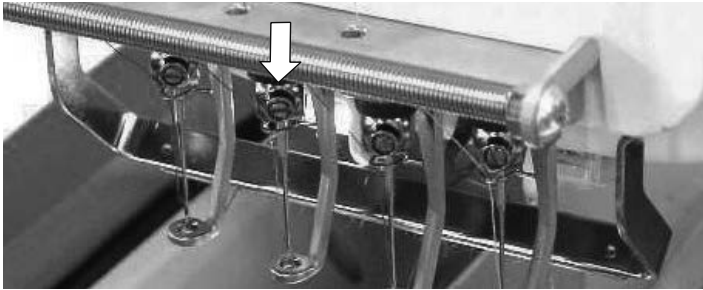

1. Set the moving head to needle bar No. 3 (see pages 33 and 46 of the instruction book). Push the needle bar No. 3 down to engage the needle bar clutch.

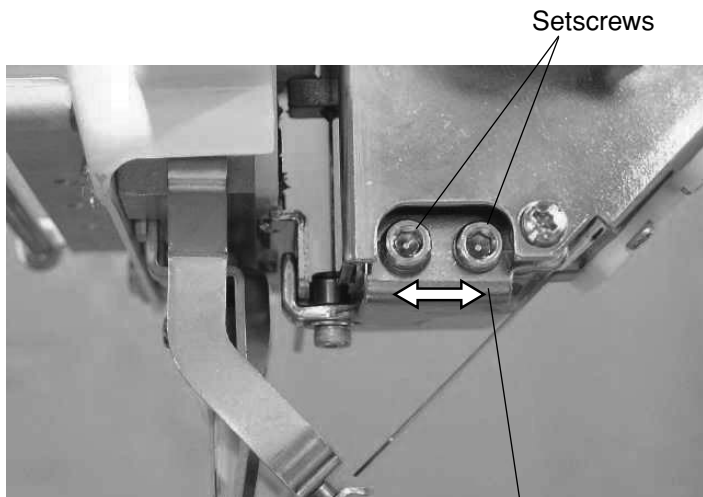

2. Turn the handwheel until the needle goes down into the needle hole. Loosen the two setscrews. Adjust the needle drop position adjusting plate. Center the needle drop position in the needle hole.

3. Adjust the hook timing (see page 41).

Needle drop position adjusting plate

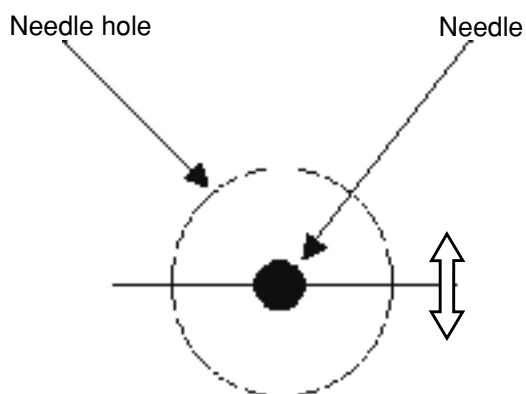

# Adjusting the Needle Height

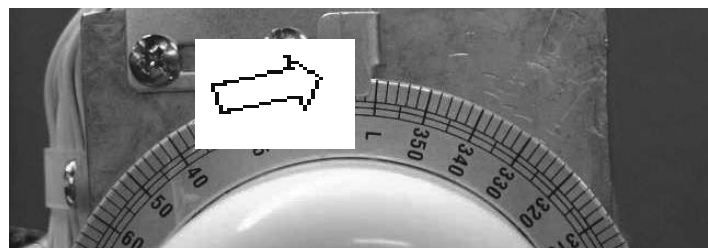
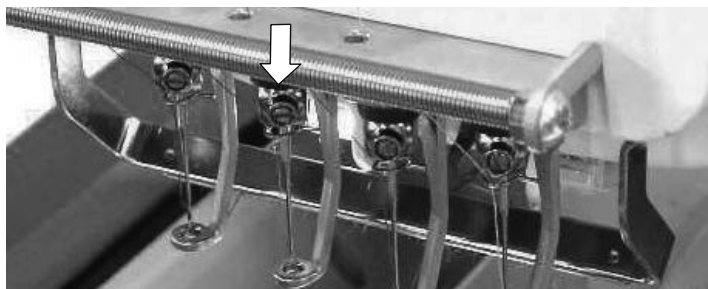

Setscrew

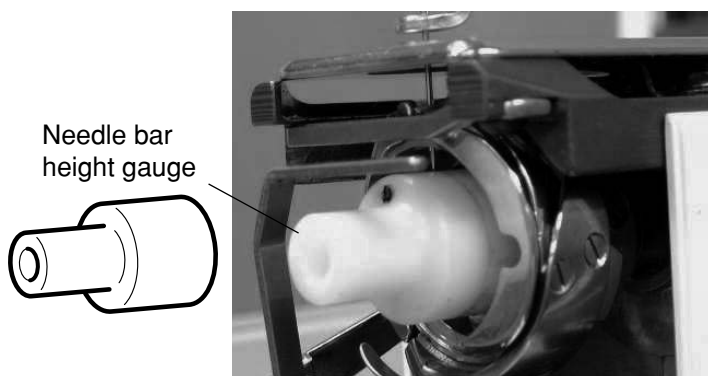

Needle bar height gauge

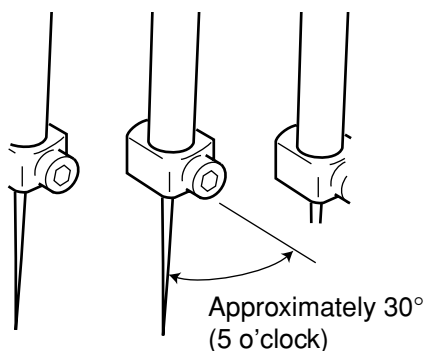

1. Remove the lower thread guide plate and thread catcher panel.
2. Remove the bobbin case.
3. Push the needle bar down to engage the needle bar clutch.
4. Turn the handwheel to set the index disk at 5°.
5. Loosen the needle bar supporter screw.
6. Insert the needle bar height gauge into the hook.
7. Adjust the needle bar height so the tip of needle slightly touches the gauge.
8. Adjust the direction of needle clamp as illustrated below (the needle clamp screw is at 5 o'clock). Tighten the setscrew.
9. Remove the needle bar height gauge.
10. Turn the handwheel to set the index disk at 270°.
11. Attach removed parts.

# Replacing the Needle Bar, Needle Spring and Cushion

1. Remove the presser foot (see pages 20 and 21).

2. Loosen the needle bar holder screw.

3. Pull the needle bar up and out of the frame.  
To remove the parts on the needle bar, pull the needle bar as far as the desired part can be removed.

4. Insert the needle bar down into the frame and put the parts on the needle bar as it goes.

5. Attach the presser foot.

6. Adjust the needle height (see 32).

7. Adjust the presser bar height (see pages 20 and 21).



Needle bar

Needle bar spring

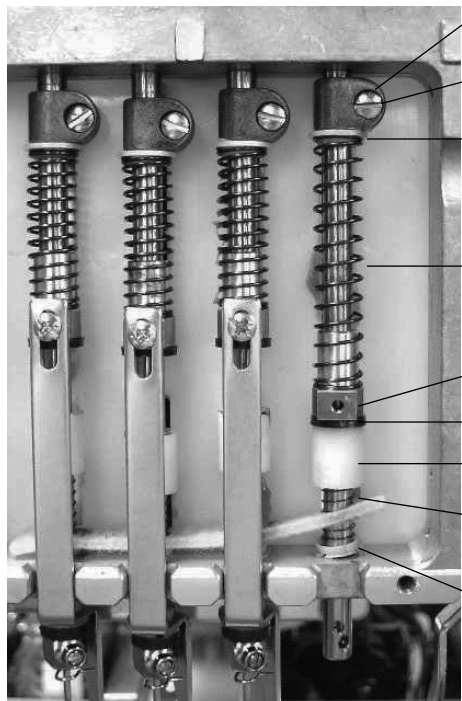

Needle bar holder

Needle bar holder screw

Spring base

Presser foot spring (lower)

Presser foot block

Stop felt

Presser foot holder

Presser foot return spring

Lower felt base

# Replacing the Rotation Stopper Plate

## To remove:

1. Remove moving head (see pages 22 and 23).
2. Remove the six setscrews and rotation stopper plate.

## To attach:

3. Attach the rotation stopper plate with the six setscrews. The setscrews should be positioned at the center of each holes when tightening each setscrews.
4. Attach moving head.

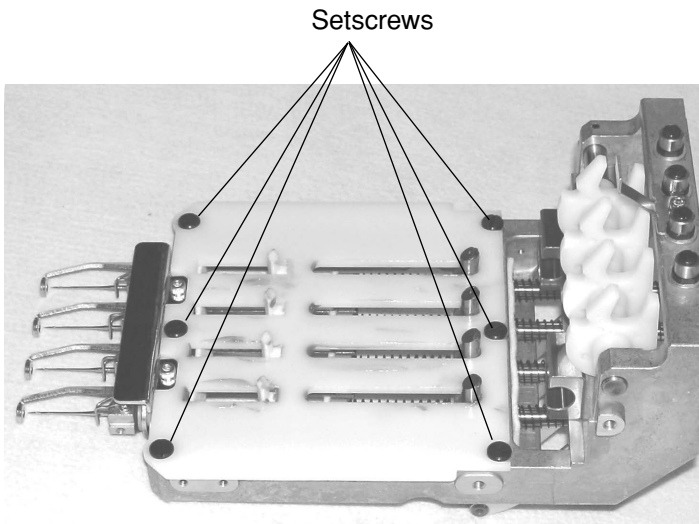

Rotation stopper plate

# Replacing the Thread Take-up Lever

1. Remove moving head (see pages 29 and 30).
2. Remove the E-ring.
3. Loosen the setscrew on the thread take-up lever shaft.
4. Pull the thread take-up lever shaft out in the direction of the arrow. Remove the thread take-up lever to replace.
5. Replace the thread take-up lever.
6. Attach the E-ring.
7. Insert a 0.2 mm thick gauge between the moving head case and thread take-up lever. Tighten the setscrew while pressing the thread take-up lever shaft in the direction of the arrow.
8. Attach the moving head.

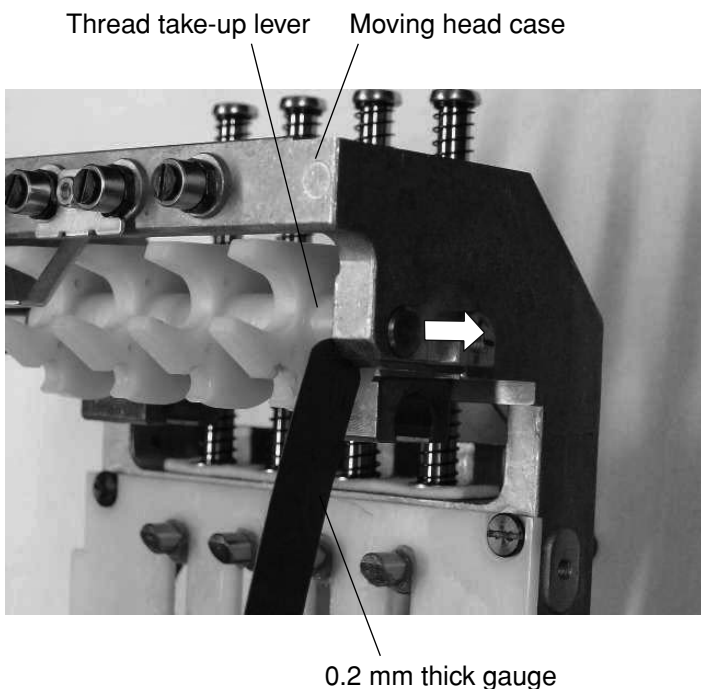
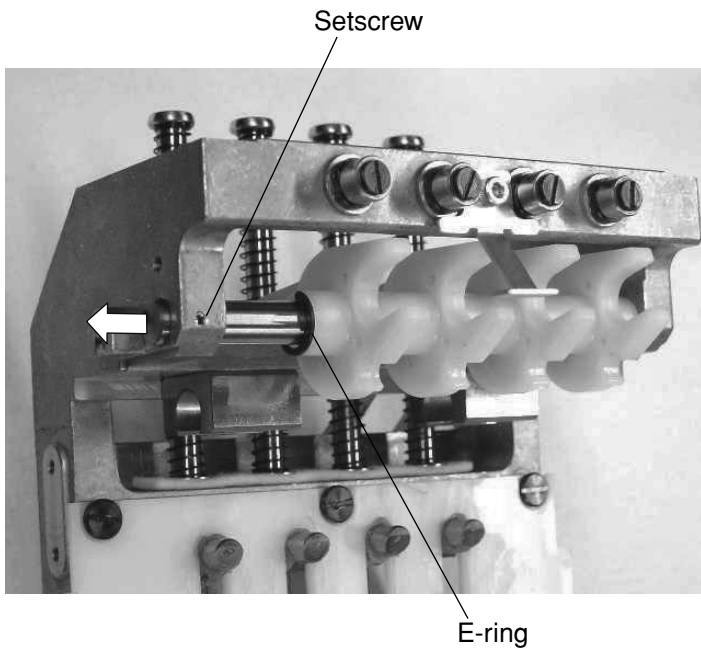



# Adjusting the Check Spring Tension

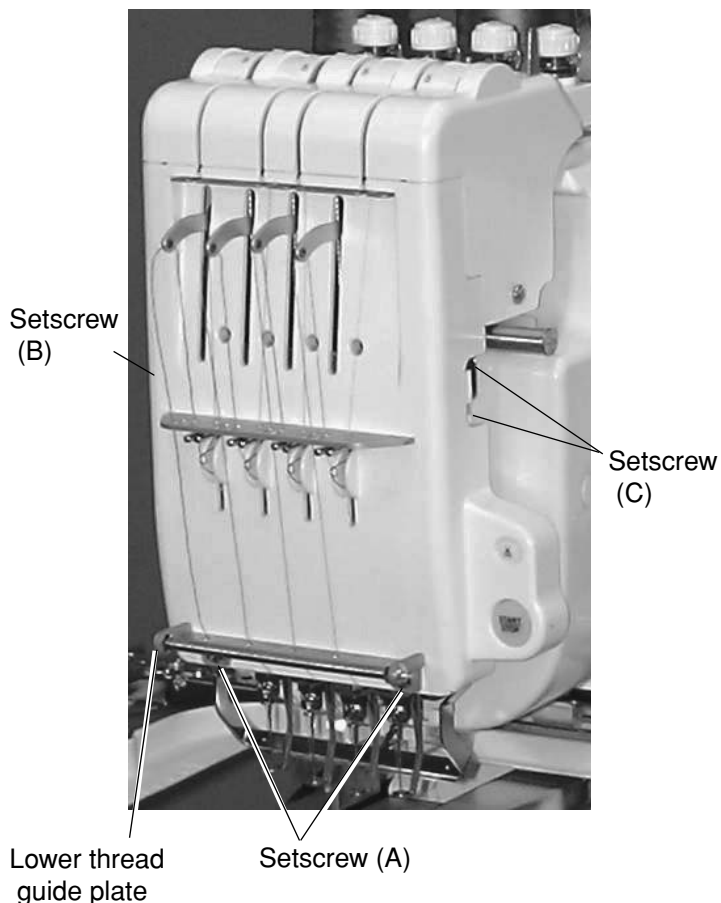

Check spring tension is not necessary to adjust under normal conditions. However, you need to adjust the tension of the check spring when it is replaced.

1. Remove the two setscrews (A) and lower thread guide plate.
2. Remove setscrew (B), two setscrews (C) and thread catcher panel.
3. Hook the tail of the check spring into the one of three slits. Use a narrow screwdriver to hook the check spring.
  - Top slit: Higher tension
  - Center slit: Standard tension
  - Bottom slit: Lower tension
4. Attach the thread catcher panel and lower thread guide plate.

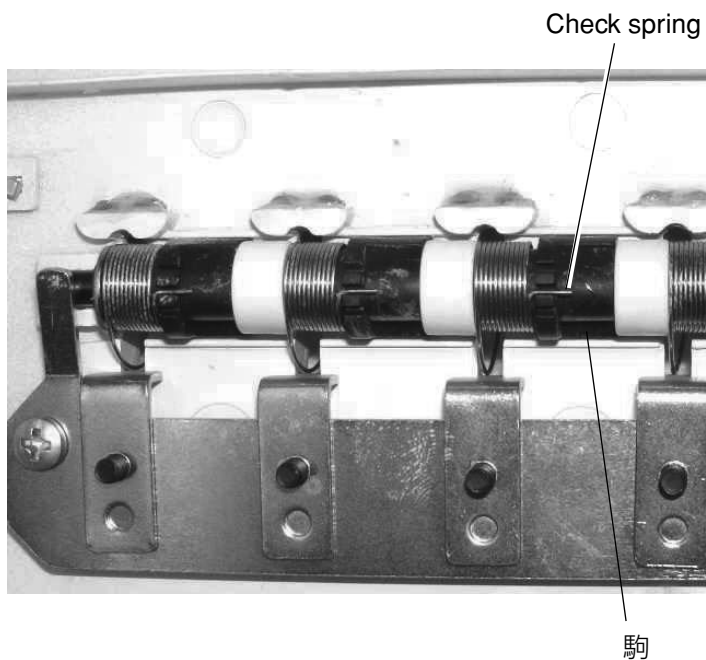

## Adjusting the Check Spring Stroke

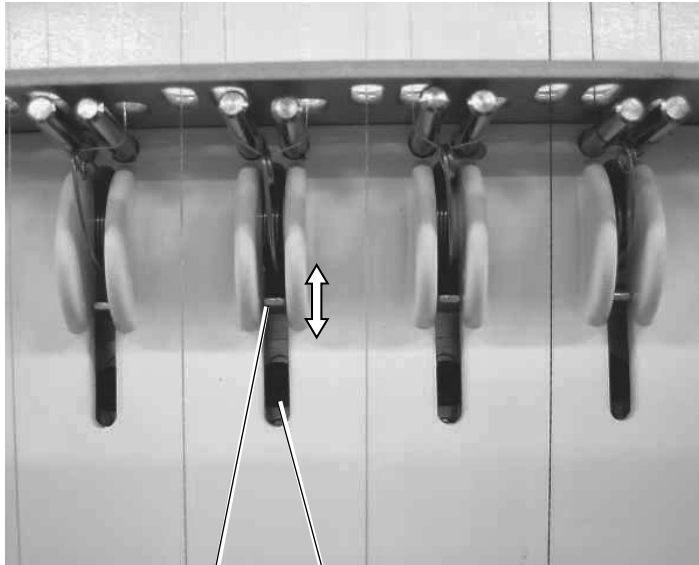

Adjustor

Setscrew

Check spring stroke is not necessary to adjust under normal conditions. However, you need to adjust the stroke of the check spring when it is replaced.

1. Loosen the setscrew. Move the adjuster up or down so the distance between the top of the check spring and the bottom side of the thread guide pin is 7 mm.

For a longer stroke, move the adjuster down.  
For a shorter stroke, move the adjuster up.



7mm

# Adjusting the Thread Catcher Holder

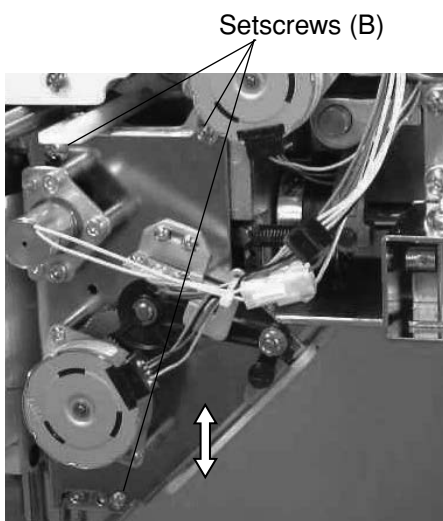
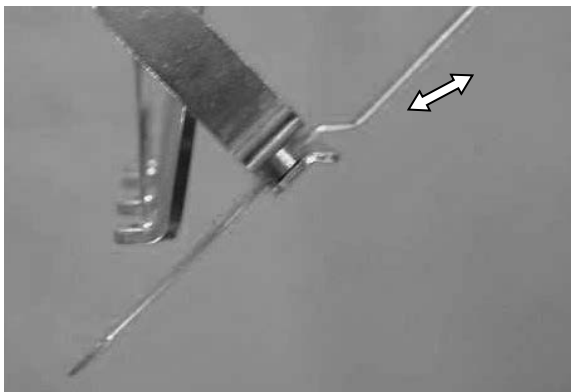
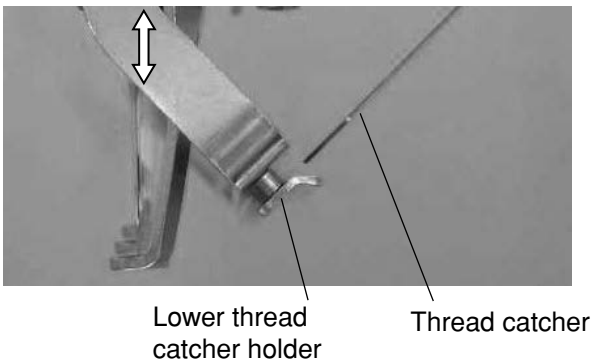
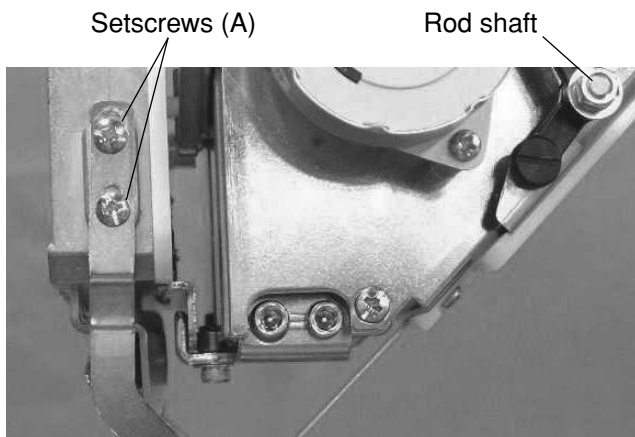

1. Remove the right cover of the stationary head (see page 5).
  2. Remove the thread catcher panel and lower thread guide plate (see pages 25 and 26).
  3. Loosen the four setscrews (A).
  4. Pull the thread catcher out to set the tip of the thread catcher on the lower thread catcher holder. Move the thread catcher holder up or down so the lower surface of the thread catcher touches the upper surface of the lower thread catcher holder.
- NOTE:**  
If an adjustment allowance of the thread catcher holder is not enough, loosen the three setscrews (B) and move the thread catcher unit.
5. Check if the thread catcher moves smoothly by moving the rod shaft with your hand. Tighten the four setscrews (A).
  6. Press the thread cutter button to test thread cutting and catching.
  7. Attach the parts removed in steps 1 and 2.

# Replacing the Thread Catcher Loop Tape

1. Remove the right cover of the stationary head (see page 5).
2. Remove the thread catcher panel and lower thread guide plate (see pages 25 and 26).
3. Remove the four setscrews (A) and remove the thread catcher holder unit.
4. Remove the two setscrews (B) and remove the two spacers (S) and lower thread catcher holder.
5. Peel the loop tape off. Stick a new loop tape on the bottom side of the thread catcher holder, aligning with the front edge of the holder. Leave a 2 mm space from the threaded hole at each side.
6. Attach the two spacers (S) and lower thread catcher holder with the two setscrews (B).
7. Attach the parts removed in steps 1 and 2.

Setscrews (A)

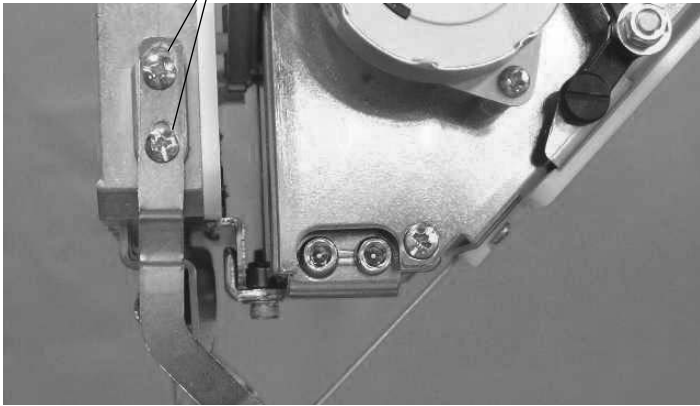

Spacers (S)

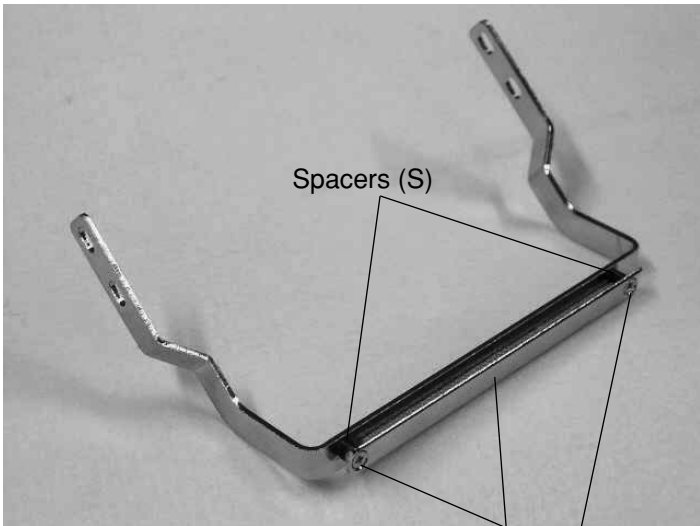

Setscrews (B)

Lower thread catcher holder

Upper thread catcher holder



2mm

2mm

Loop tape

# Replacing the Lateral Moving Unit

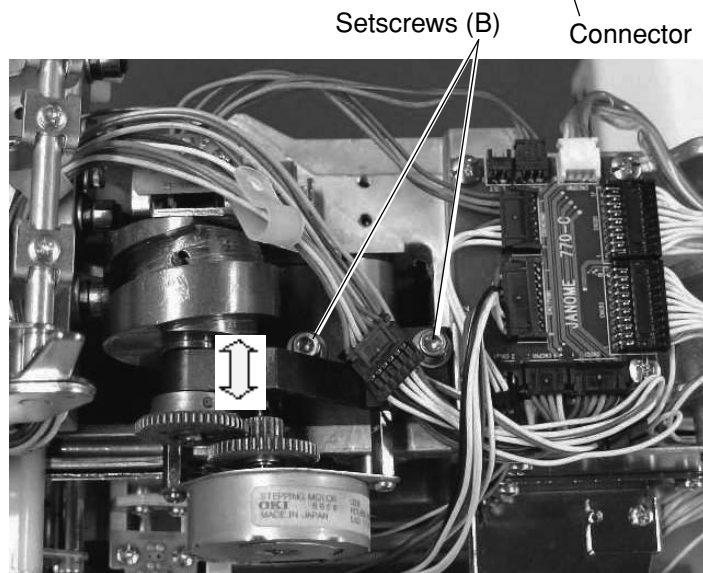
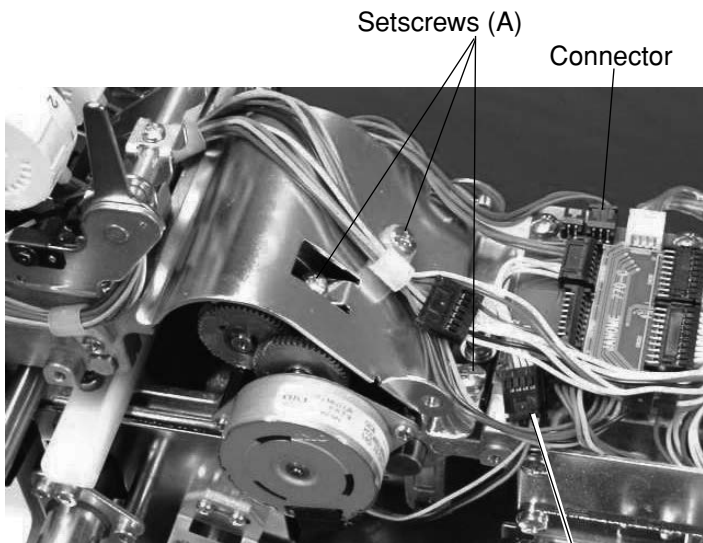

## To remove:

1. Remove the spool stand, right cover and left cover (see pages 4 and 5).
2. Remove the tension unit cover (see page 4).
3. Remove the three setscrews (A) and remove the driver cover.
4. Disconnect the connectors.
5. Remove the two setscrews (B) and remove the lateral moving unit.

## To attach:

6. Attach the lateral moving unit and loosely fix it with the two setscrews (B).
7. Push the needle bar down and rotate the handwheel to set the index disk at "L".
8. Adjust the position of the lateral moving unit so the needle enters into the center of the hole in the needle plate. Tighten the two set screws (B) securely.
9. Connect the connectors and attach the parts removed in steps 1 to 3.

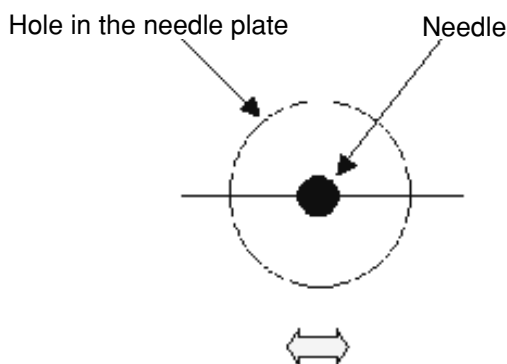

# Adjusting the Hook Timing

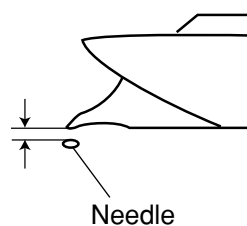
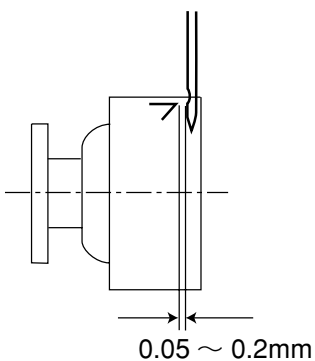
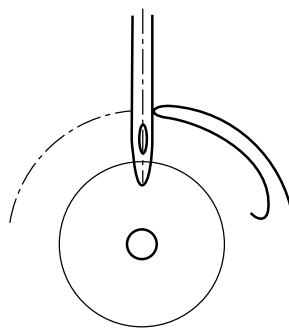
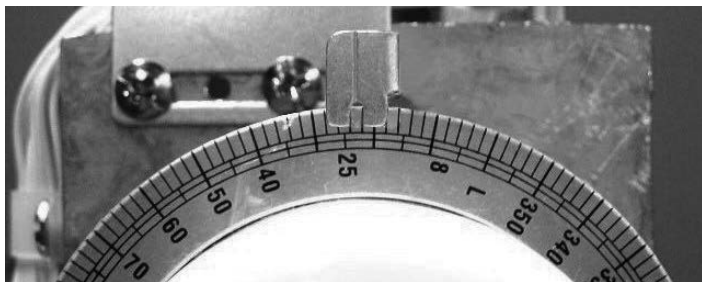
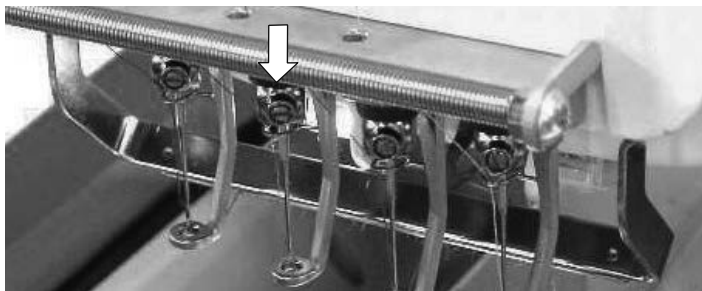
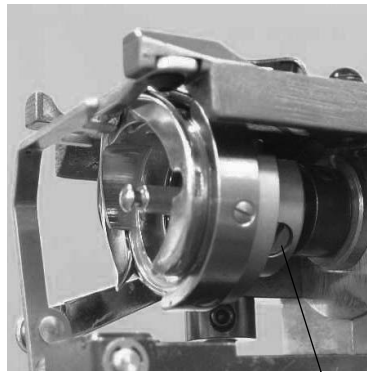
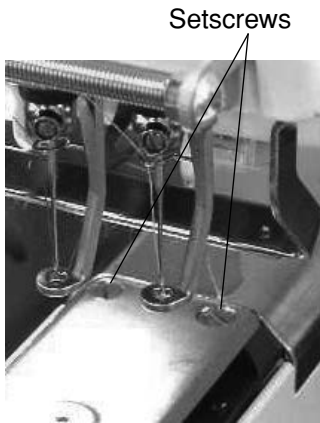

1. Remove the setscrews and needle plate.
  2. Loosen the three setscrews on the hook.
  3. Select No. 3 needle bar in the Ready to Sew mode (see the instruction book) and push the needle bar down.
  4. Turn the handwheel to set the index disk at 21°.
- NOTE:**  
To prevent the needle from hitting the hook body, hold the hook with the hook point up while turning the handwheel.
5. Turn the hook to align the hook point with the right side of the needle (use DBxK5Q1NY needle).
- NOTE:**  
Maintain a clearance between the needle and hook point within 0.05 – 0.20 mm.
6. Tighten the three setscrews securely.
  7. Check the position of the hook stopper (see page 42).

## Adjusting the Position of the Hook Stopper

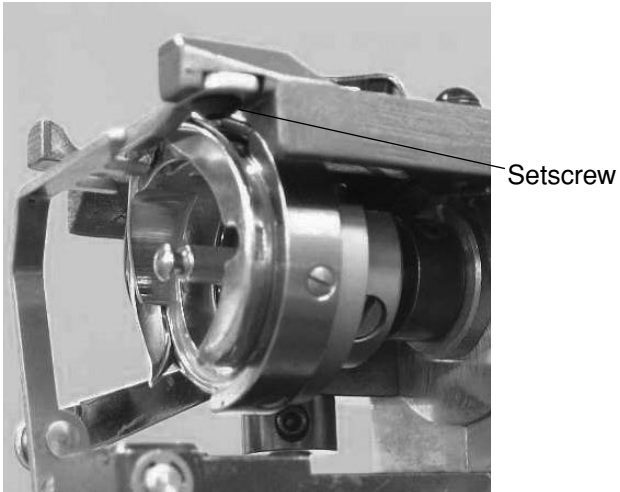

1. Loosen the setscrew to move the hook stopper.
2. Move the hook stopper to align the center with the needle and make a 0.6 – 0.8 mm clearance between the hook. Tighten the setscrew securely.

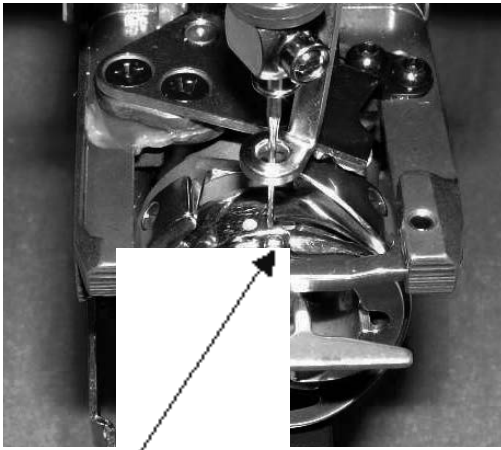

Align the center with the needle.

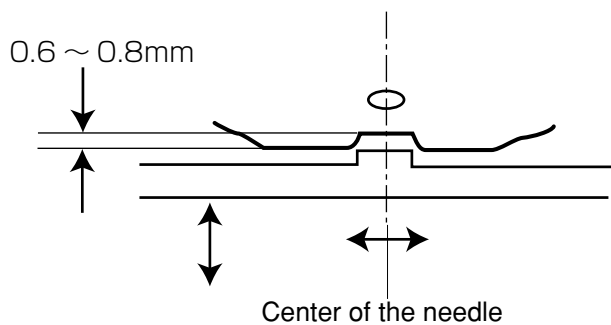

# Replacing the Thread Cutter Driving Roller

1. Remove the spool stand and right cover (see pages 4 and 5).
2. Loosen the setscrew and remove the pivot pin. Remove the lever unit from the frame.
3. Loosen the setscrew and remove the roller shaft. Replace the thread cutter driving roller.
4. Insert the 0.05 mm thickness gauge between the lever unit and thread cutter driving roller. Tighten the setscrew securely.
5. Attach the lever unit to the frame and insert the pivot pin. Tighten the setscrew securely.
6. Adjust the position of the dynamic cutter blade (see page 45).
7. Attach the parts remove in step 1.

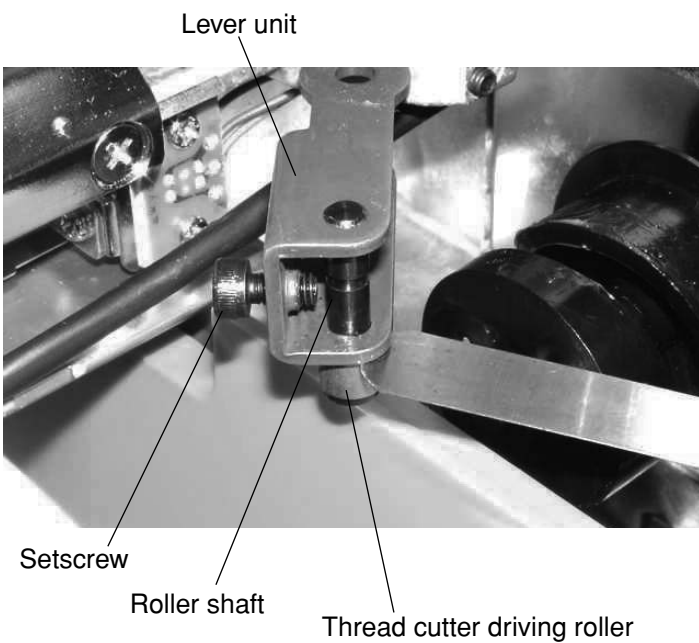
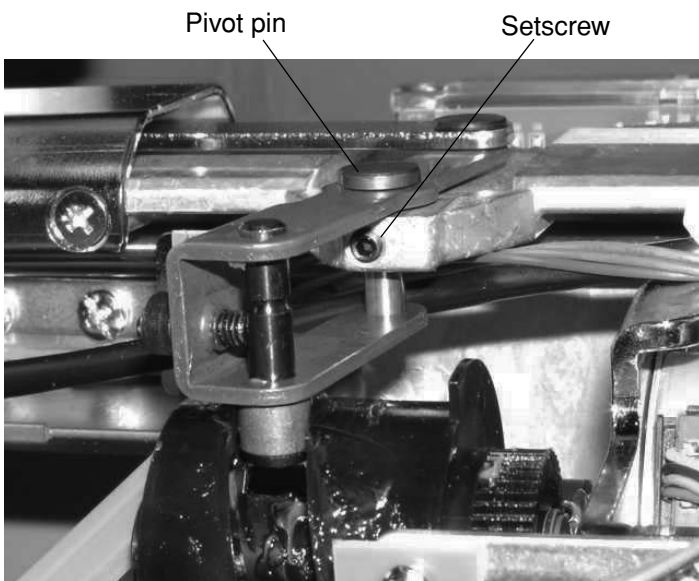



# Replacing the Dynamic Cutter Blade

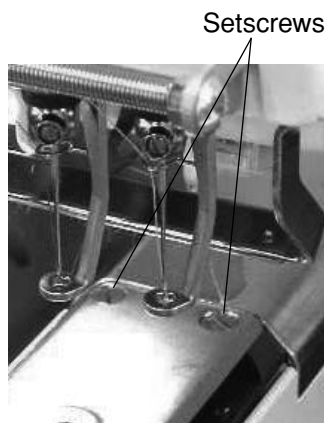

Setscrew  
Drive shaft ring



Drive shaft unit

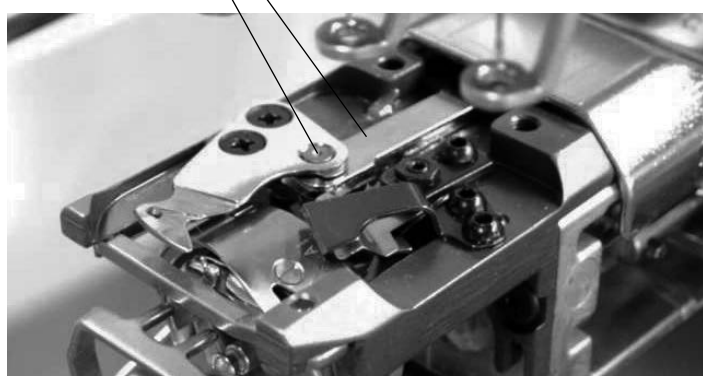

Lever unit  
Link shaft

1. Remove the setscrews and needle plate.
  2. Turn the power switch on while pressing the Start/ Stop button and Thread cutter button at the same time to open the **Factory Adjusting** window. Press the **Phase** key to open the **Phase Sensor** adjusting window and press the **All Int** key. Press the **Cancel** key to return to the previous window. Press the **Cut Adjust** key to open the **Cut Motor** adjusting window. Press **Divide** key to move the dynamic cutter blade forward.
  3. Loosen the setscrew and remove the drive shaft ring.
  4. Remove the cutter drive shaft unit from the frame. Remove the two setscrews and replace the dynamic cutter blade.
  5. Insert the drive shaft into the frame and link pin of the cutter drive shaft unit into the hole in the lever unit.
  6. Attach the drive shaft ring and tighten the setscrew while pressing the ring and shaft unit each other with your fingers.
- NOTE:**  
Be sure that there is no thrust play in the shaft unit.
7. Adjust the cutter blades position (see following pages) and test auto thread cutting.
  8. Attach the needle plate.

## Replacing the Static Cutter Blade

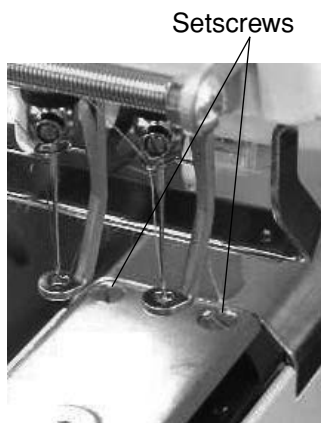

1. Remove the setscrews and needle plate.
2. Press **Divide** key to move the dynamic cutter blade forward.
3. Remove the two setscrews and replace the static cutter blade.
4. Attach the static cutter blade and tighten the set screws while pressing the static cutter blade in the direction of the arrow.

### NOTE:

If the dynamic cutter blade interferes with the left corner of the static cutter blade when moving the dynamic cutter blade, shift the static cutter blade to the right.

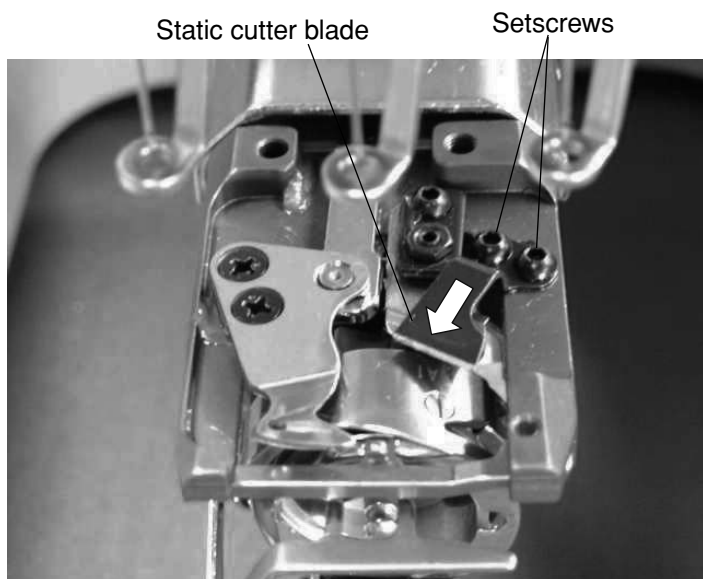

5. Adjust the cutter blades position (see following pages) and test auto thread cutting.
6. Attach the needle plate.

# Adjusting the Static Cutter Blade

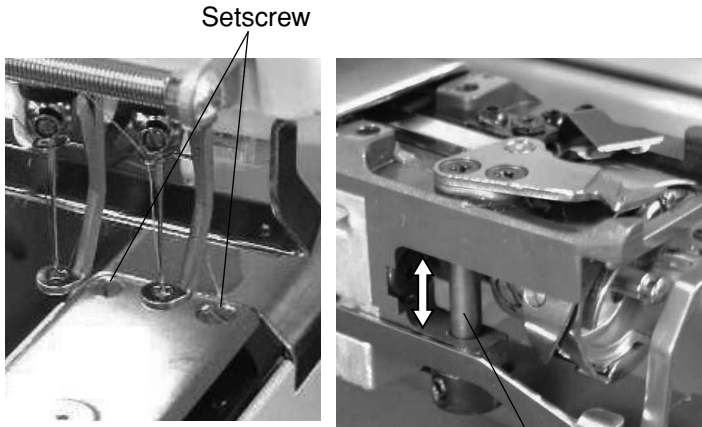

Setscrew

Cutter drive shaft

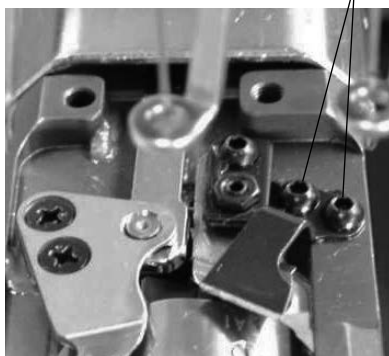

Upper adjusting screw

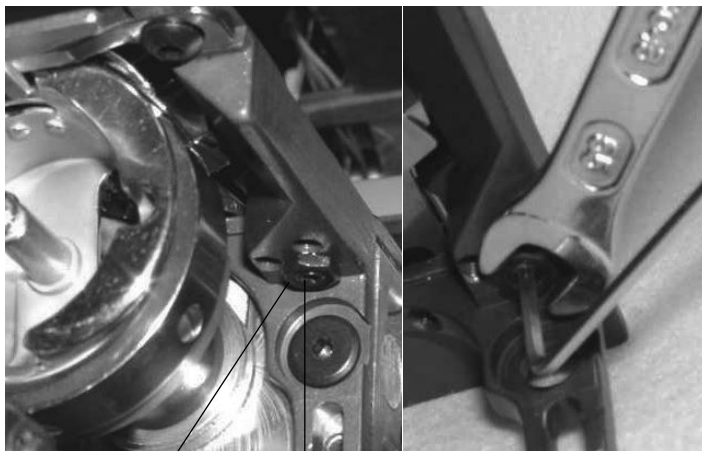

Nut

Lower adjusting screw



1. Remove the setscrews and needle plate.
2. Press **Init** key to move the dynamic cutter blade to the home position.
3. Check if there is no play in the cutter drive shaft and eliminate a play if any.
4. The front tip of the dynamic cutter blade should extend 0.3 to 0.5 mm from the edge of the static cutter blade.  
If there is a gap between the edge of the static cutter blade and the dynamic cutter blade, adjust the height of the static cutter blade.  
Loosen slightly the two setscrews and nut on the adjusting screw. Screw in the adjusting screw until the edge of the static cutter blade evenly touches the upper surface of the dynamic cutter blade. Tighten the two setscrews and nut.
5. Test auto thread cutting with polyester threads size #120 both in the needle and bobbin.
6. Attach the needle plate.

# Adjusting the Dynamic Cutter Blade



1. Remove the spool stand, static head right cover and left cover (see pages 4 – 6).
2. Remove the two setscrews and needle plate.
3. Press **Divide** key to move the dynamic cutter blade to the home position.
4. Loosen the setscrew and turn the pivot pin to adjust the position of the dynamic cutter blade so the front tip of the dynamic cutter blade is in line with the center of the needle drop position.

## NOTE:

If an adjustable allowance is not enough, loosen the two setscrews and move the thread cutter drive unit in the direction of the arrow.

5. Test auto thread cutting with polyester threads size #120 both in the needle and bobbin.
6. Attach the needle plate.
7. Attach the parts removed in step 1.

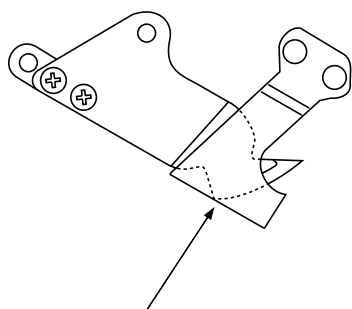
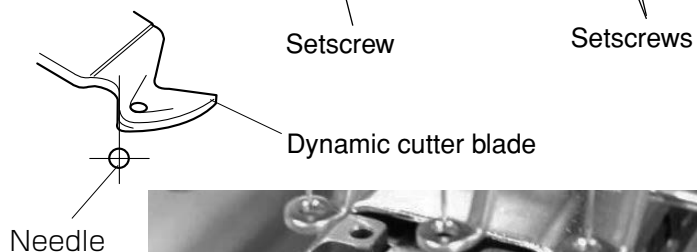
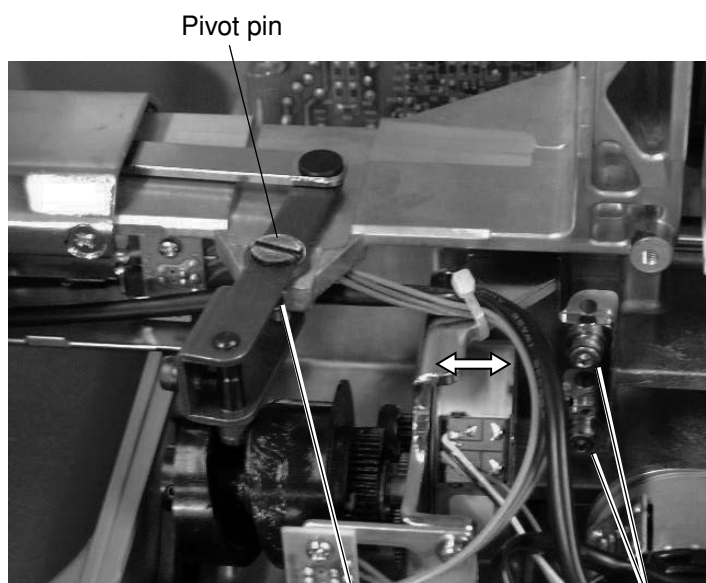

Align the point of the dynamic cutter blade with the edge of the static cutter blade.

# Adjusting the Bobbin Thread Holder

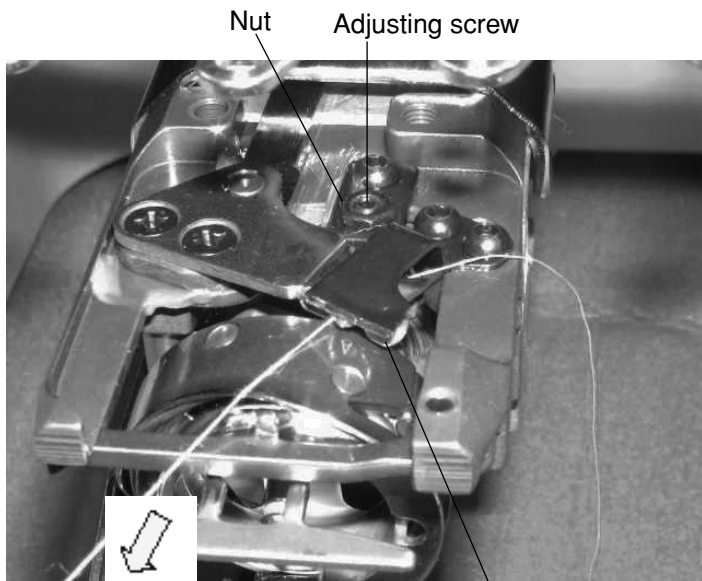
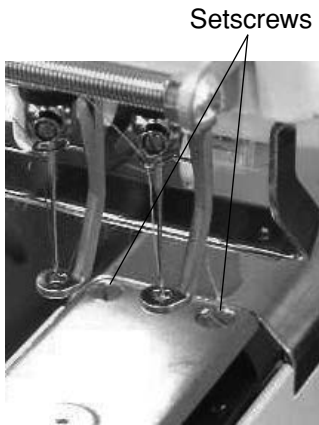

1. Remove the setscrews and needle plate.
2. Place the bobbin thread between the dynamic cutter blade and bobbin thread holder. Close the dynamic cutter blade to clamp the bobbin thread.
3. Loosen the nut and turn the adjusting screw to adjust the clamping pressure.
4. Pull the bobbin thread with a tension gauge and read the tension when the bobbin thread is coming out. The tension should be 20 – 25 grams. Check the tension several times.
5. Tighten the nut while holding the adjusting screw in place.
6. Attach the needle plate.



# Adjusting the Thread Keeper

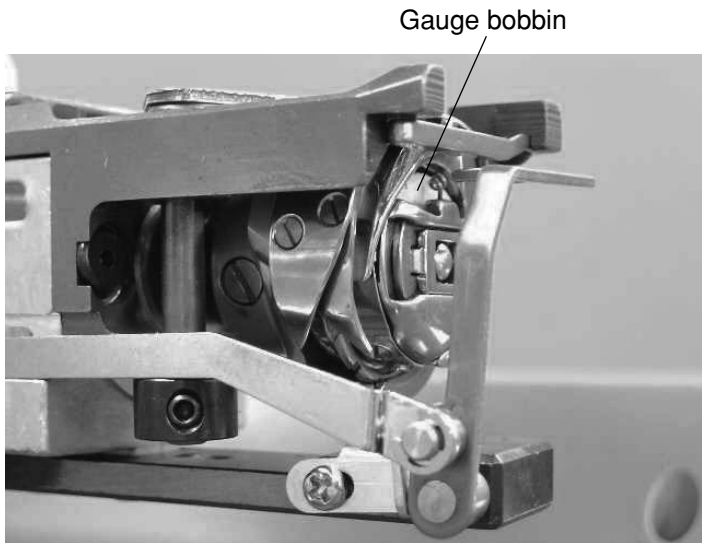

1. Insert the gauge bobbin (a 1.6 mm thick spacer stuck on it) into the bobbin case and insert the bobbin case into the hook.
2. Loosen the two setscrews (A) and insert a 2 mm thick gauge between the frame of the solenoid and washer on the plunger.
3. Slide the solenoid in the direction of the arrow until the tips of the thread keeper touch the 1.6 mm spacer on the bobbin.  
Tighten the two setscrews (A) securely.

**NOTE:**

The clearance between the bobbin and the tips of the thread keeper should be 1.4 – 1.8 mm.

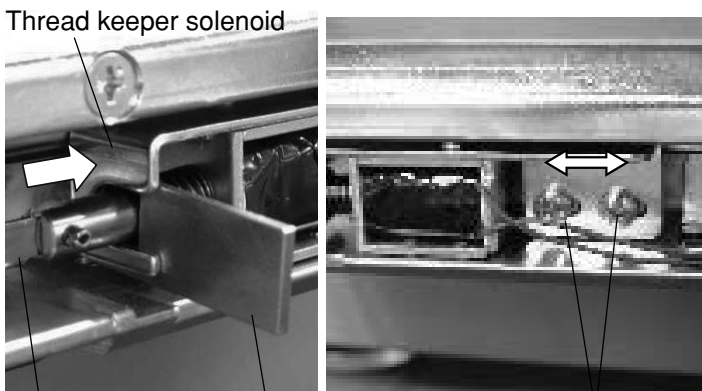

Thread keeper solenoid  
Thread keeper rod  
2 mm thick gauge  
Setscrews (A)

4. Loosen the setscrew (B) and move and press the stopper against the thread keeper rod.  
Remove the 2 mm thick gauge and push the thread keeper toward the bobbin to check if the tips of the thread keeper touches the 1.6 mm thick spacer on the bobbin.
5. Tighten the setscrew (B) securely.
6. Attach the needle plate.

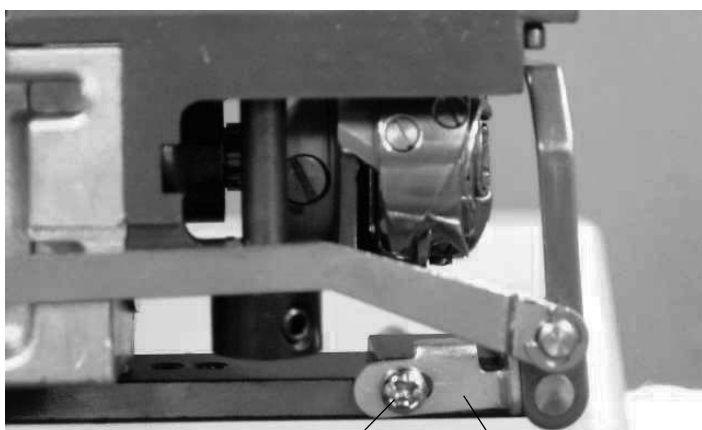
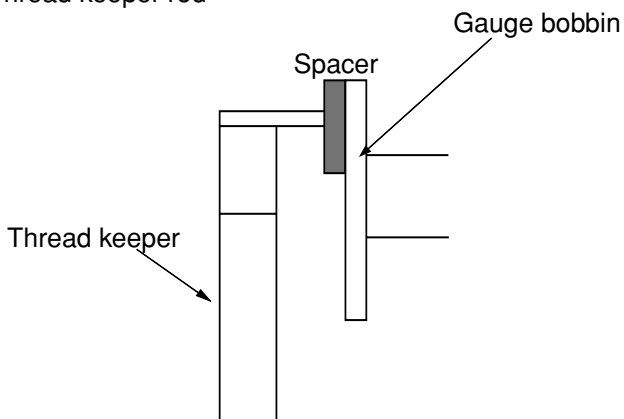

Setscrew (B)  
Stopper

# Adjusting the X-carriage Belt Tension

1. Remove the spool stand, static head right cover and left cover (see pages 4 – 6).
2. Loosen the two setscrews (A) and remove the X-carriage cover.
3. Shift the hoop supporter to the extreme left end. Set the push-pull gauge at the right side of the machine frame and push the X-carriage timing belt. The gauge should read 600 grams when the upper portion touches the lower portion.
4. If the belt tension is too tight or loose, slightly loosen the two setscrews (B) and move the X-belt pulley in the direction of the arrow to adjust the belt tension. Tighten the tow setscrews (B) securely and check the tension again.

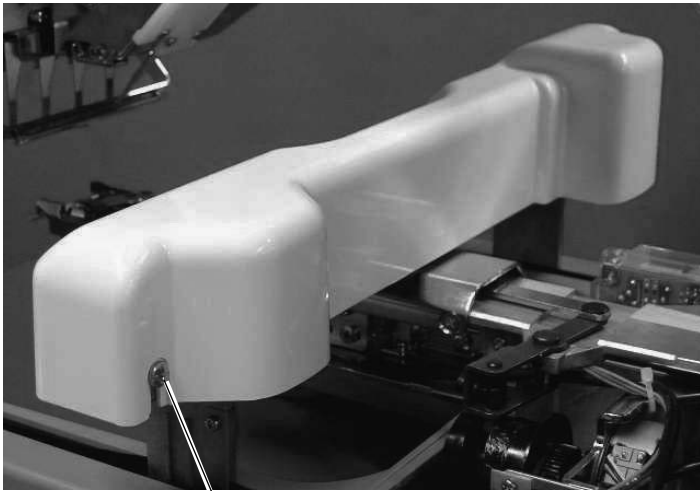

Setscrews (A)

Push-pull gauge

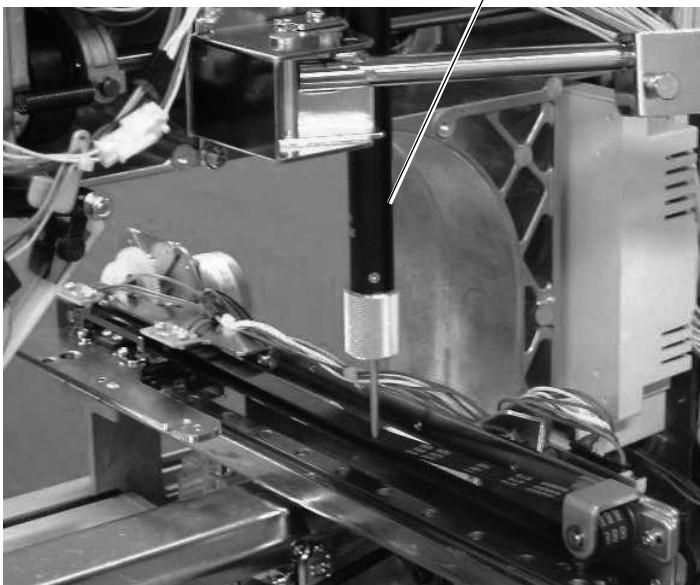

5. Attach the X-carriage cover with the two setscrews (A).
6. Attach the parts removed in step 1.

## NOTE:

When moving the X-belt pulley, insert a 4 mm rod into the side hole and pry the base plate of the pulley.

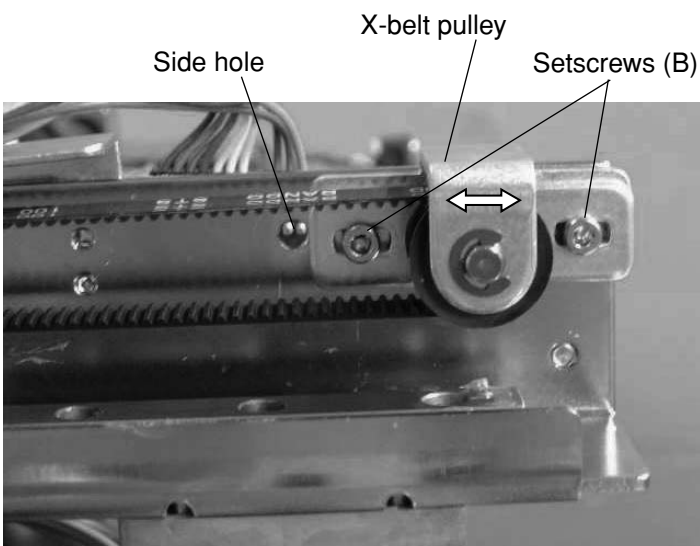

## Replacing the X-carriage Belt



Setscrews (A)

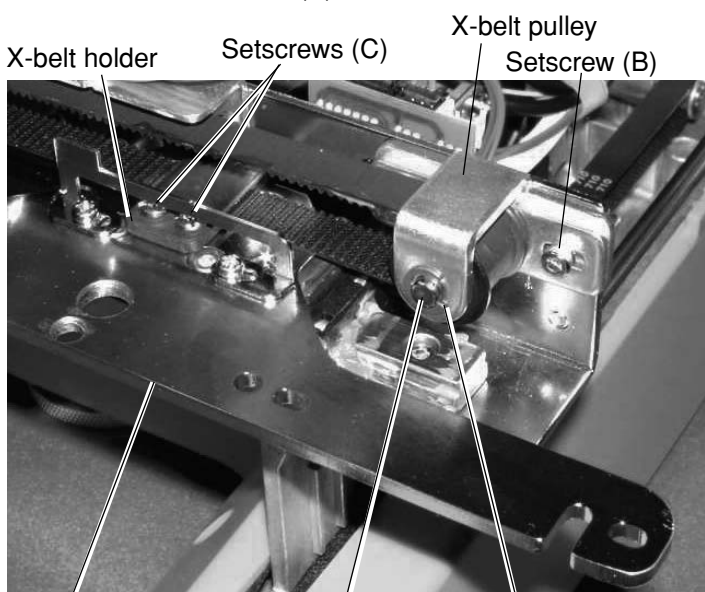

X-belt holder

Setscrews (C)

X-belt pulley

Setscrew (B)

Hoop supporter

X-belt pulley shaft

E-ring



Drive pulley shaft unit

Setscrews (D)

1. Remove the spool stand, static head right cover and left cover (see pages 4 – 6).
2. Loosen the two setscrews (A) and remove the X-carriage cover.
3. Shift the hoop supporter to the extreme left end. Remove the two setscrews (C) and the X-belt holder.
4. Loosen the two setscrews (B) and shift the X-belt pulley in the direction of the arrow.
5. Remove the E-ring and pull the X-belt pulley shaft to remove the X-belt pulley.
6. Remove the two setscrews (D) and drive pulley shaft unit.
7. Replace the X-carriage belt.
8. Attach the parts removed in steps 3 – 6.
9. Adjust the X-carriage belt tension (see the previous page).
10. Attach the parts removed in steps 1 – 2.



# Adjusting the Y-carriage Belt Tension

1. Remove the spool stand, static head right cover and left cover (see pages 4 – 6).
2. Shift the X-carriage to the extreme front end.
3. Shift the X-carriage to the extreme front end. Set the push-pull gauge in line with the front end of the base frame and push the Y-carriage timing belt. The gauge should read 280 grams when the upper portion touches the lower portion.
4. If the belt tension is too tight or loose, slightly loosen the two setscrews (A) and move the Y-belt pulley in the direction of the arrow to adjust the belt tension. Tighten the two setscrews (A) securely and check the tension again.
5. Attach the parts removed in step 1.

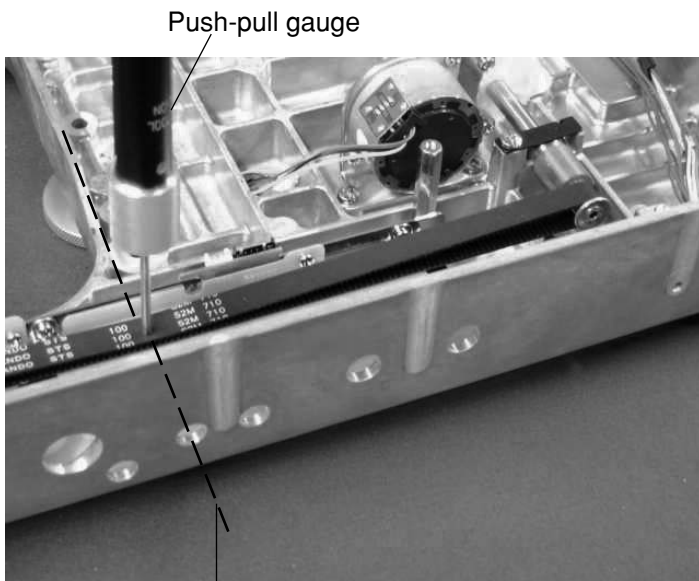

Front end of the base frame

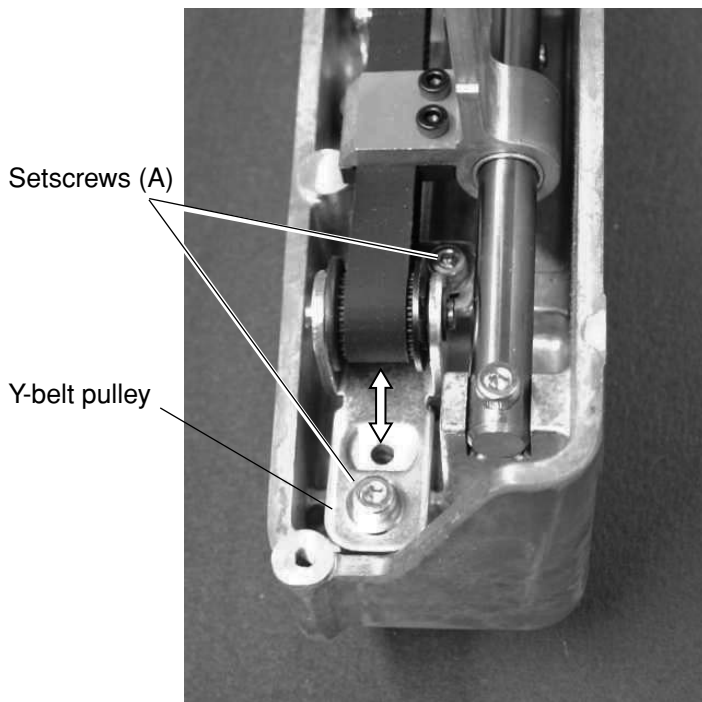

# Replacing the Y-carriage Belt

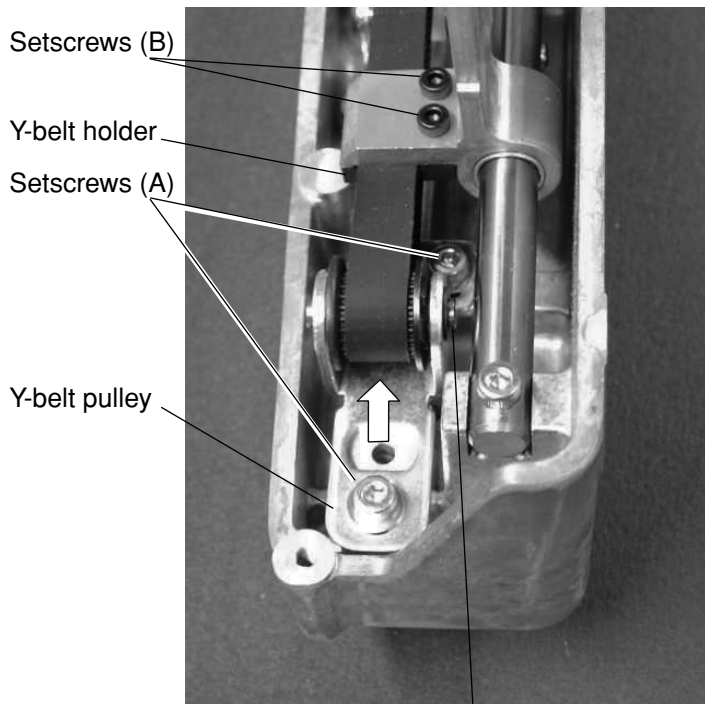

E-ring  
Y-belt pulley shaft

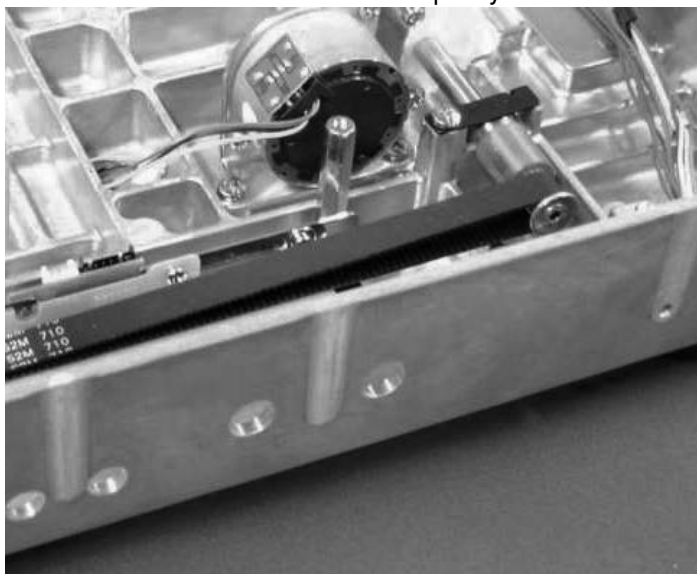

1. Remove the spool stand, static head right cover and left cover (see pages 4 – 6).
2. Remove the two setscrews (B) and the Y-belt holder.
3. Loosen the two setscrews (A) and shift the Y-belt pulley in the direction of the arrow.
4. Remove the E-ring and pull the Y-belt pulley shaft to remove the Y-belt pulley.
5. Replace the Y-carriage belt.
6. Attach the parts removed in steps 2 – 5.
7. Adjust the Y-carriage belt tension (see the previous page).
8. Attach the parts removed in step 1.

# Adjusting the Timing Belt Tension

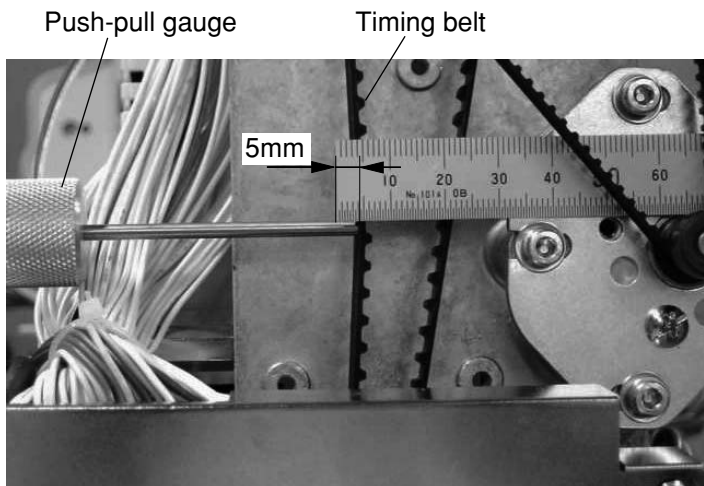

1. Remove the spool stand, static head right cover and left cover (see pages 4 – 6).
2. Place a scale on the DC motor. Set the push-pull gauge in line with the scale as illustrated and push the timing belt. The gauge should read 300 grams when the belt deflect 5 mm.
3. If the belt tension is too tight or loose, remove the three setscrews (A) and CPU board, then slightly loosen the two setscrews (B) and move the idler in the direction of the arrow to adjust the belt tension. Tighten the two setscrews (B) securely and check the tension again.
4. Attach the parts removed in step 1.

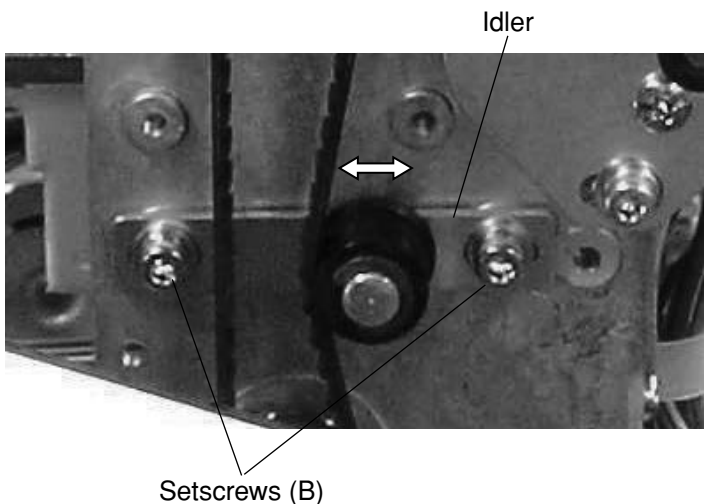
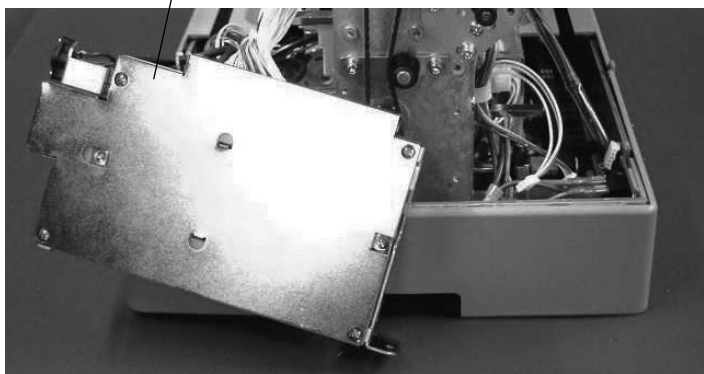
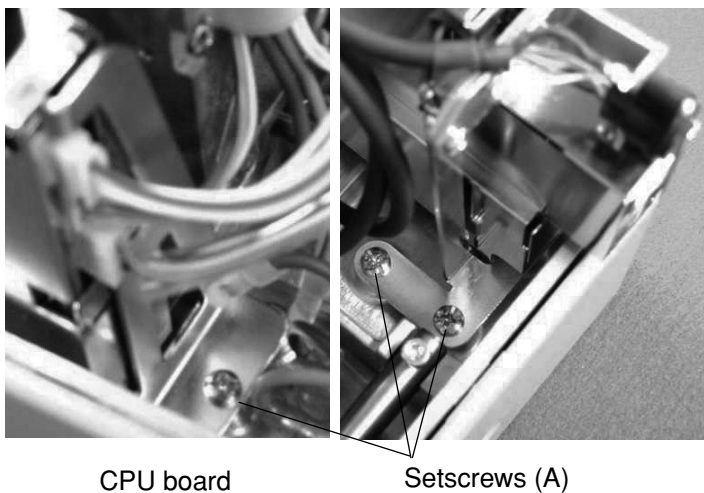

# Replacing the Timing Belt

1. Remove the spool stand, static head right cover and left cover (see pages 4 – 6).
2. Remove the two setscrews (A) and the pointer.
3. Remove the three setscrews (B) and CPU board.
4. Remove the motor belt (see page 57).
5. Loosen the two setscrews (C) and remove the idler.
6. Replace the timing belt.
7. Attach the parts removed in steps and 5.
8. Adjust the timing belt tension (see the previous page).
9. Check the following items and adjust them if necessary.
  - Needle bar lowest position
  - Hook timing
  - Thread cutter timing
10. Attach the parts removed in steps 1 – 3.

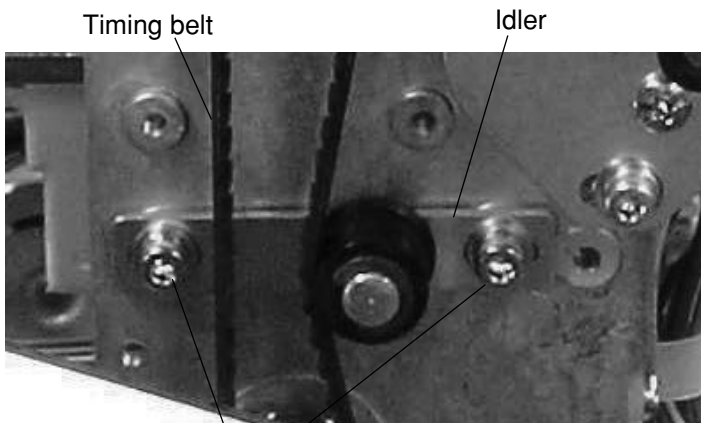
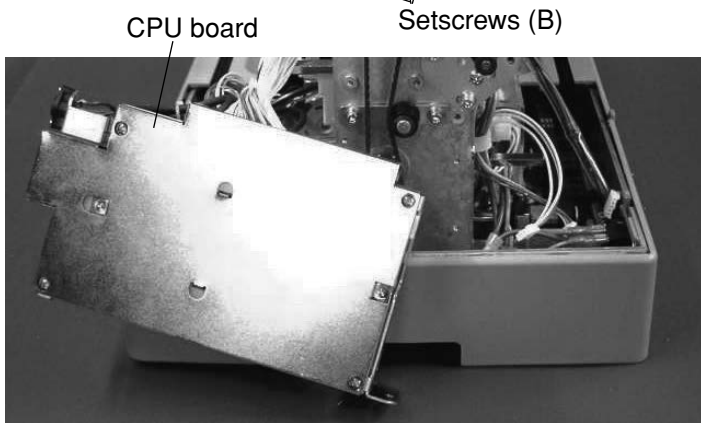
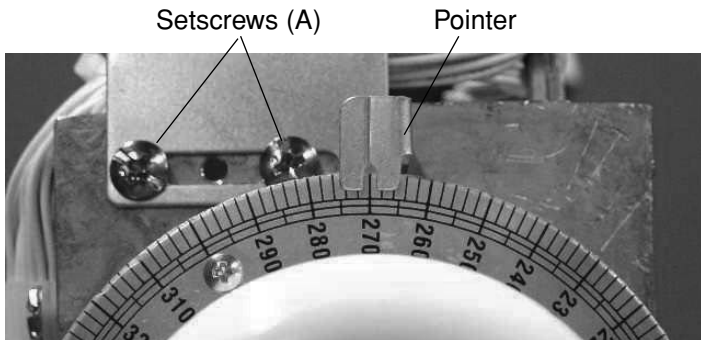

# Adjusting the Motor Belt Tension

1. Remove the spool stand, static head right cover and left cover (see pages 4 – 6).
2. Place a scale under the stud bolt. Set the push-pull gauge in line with the scale as illustrated and push the timing belt. The gauge should read 300 grams when the belt deflect 3 mm.
3. If the belt tension is too tight or loose, slightly loosen three setscrews and move the motor in the direction of the arrow to adjust the belt tension. Tighten the three setscrews securely and check the tension again.
4. Attach the parts removed in step 1.

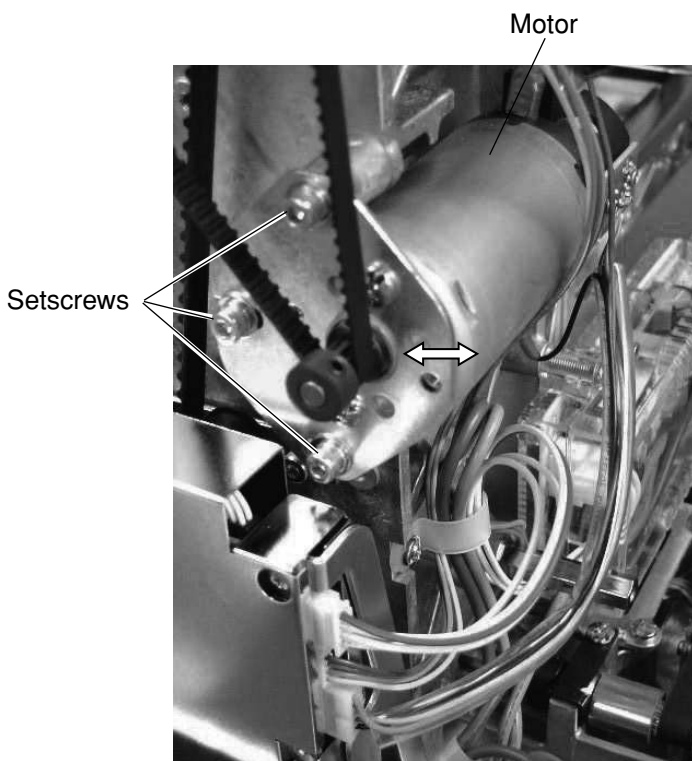
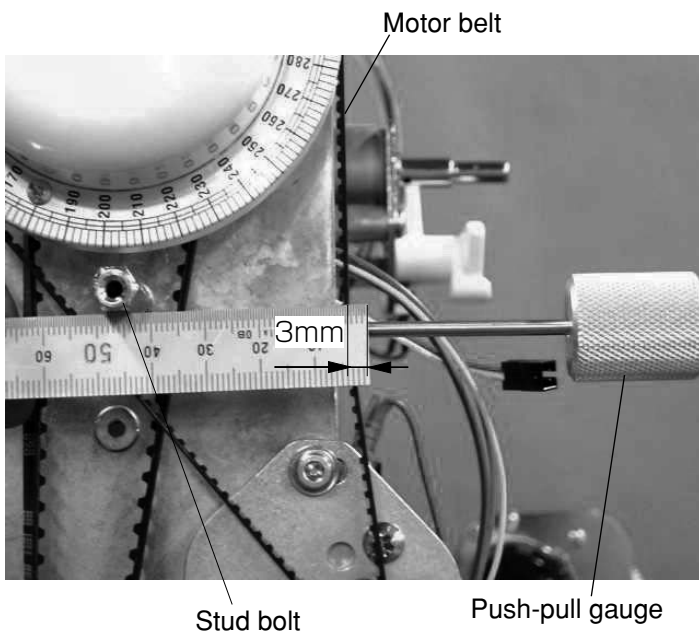

# Replacing the Motor Belt

1. Remove the spool stand, static head right cover and left cover (see pages 4 – 6).
2. Remove the two setscrews (A) and the pointer.
3. Remove the three setscrews (B) and DC motor.
4. Replace the motor belt. Attach the motor and motor belt.
5. Adjust the motor belt tension (see the previous page).
9. Attach the parts removed in step 1.

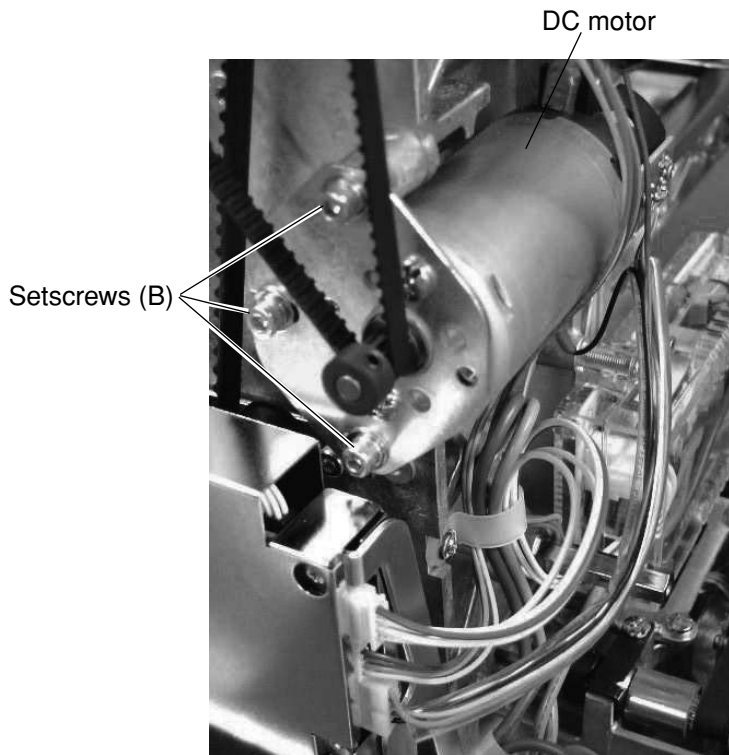
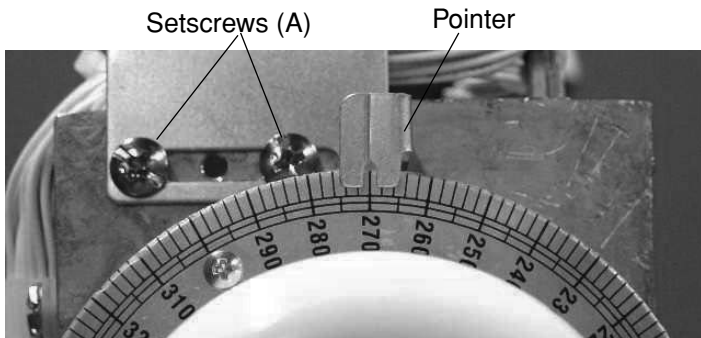

# Replacing the DC Motor

1. Remove the spool stand, static head right cover and left cover (see pages 4 – 6).
2. Disconnect the motor connector. Remove the three setscrews (A) and DC motor.
3. Attach the DC motor and tighten the three setscrews (A) slightly. Connect the motor connector.
4. Adjust the motor belt tension (see page 56).
5. Attach the parts removed in step 1.

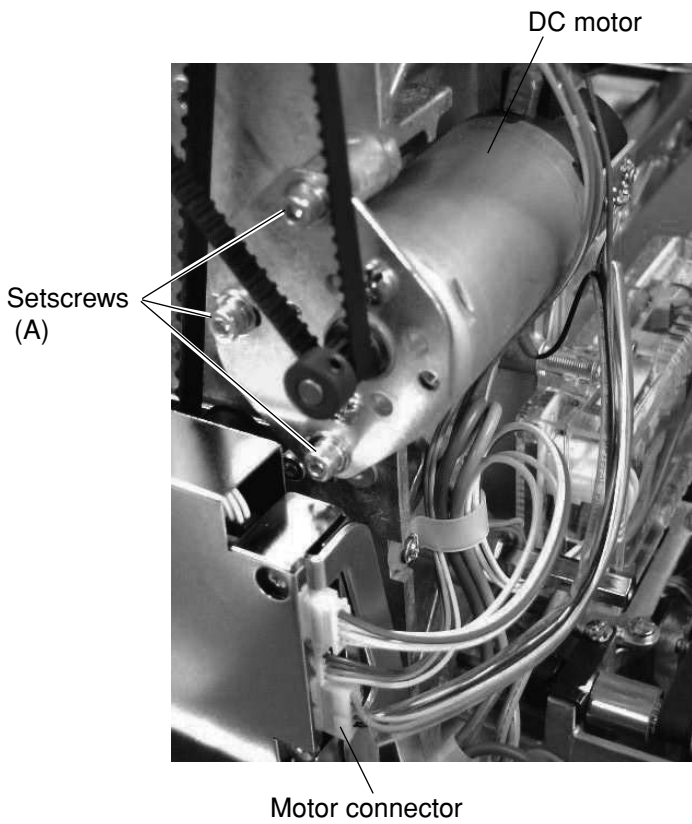

## To Reset Motor Drive Time

A warning message will appear when the motor drive time has exceeded 1,000 hours.

- \* The warning will be displayed until the motor is replaced and the motor drive time clock reset.

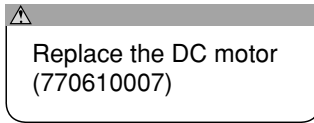

### Replacing the DC Motor (770610007)

1. Remove the spool stand, static head right cover, right cover and left cover.
2. Disconnect the motor connector. Remove the 3 setscrews (A) and the motor.
3. Attach the DC motor and tighten the 3 setscrews (A) slightly. Connect the motor connector.
4. Adjust the motor belt tension.
5. Attach the parts removed in step 1.

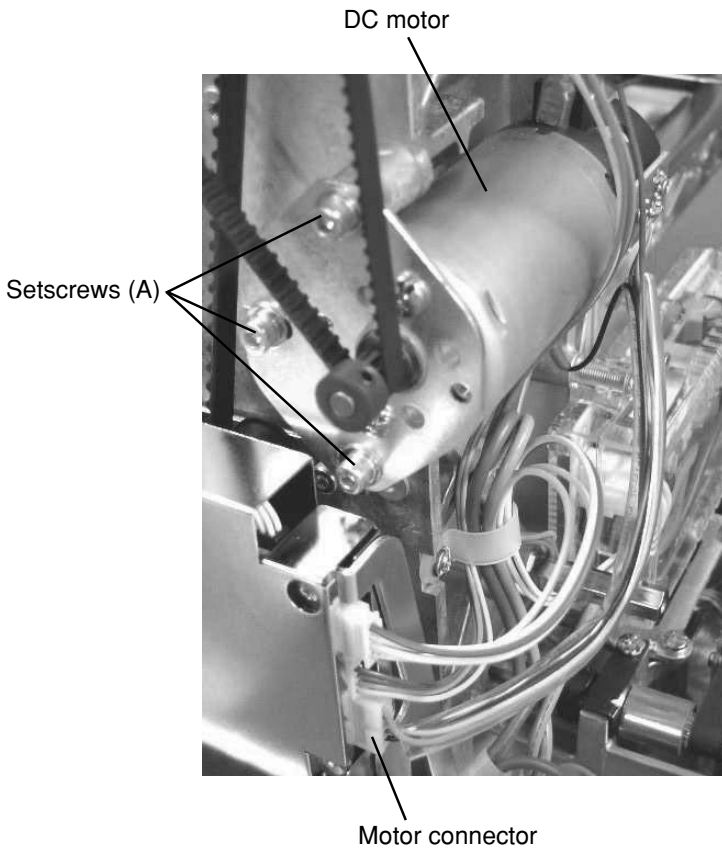

### To reset motor drive time

1. After DC motor replacement, turn the power switch "ON" while pressing the needle forward button and the bobbin winding button
2. Press the "CLEAR" key to reset the motor drive time clock.
3. Turn the power switch "OFF".

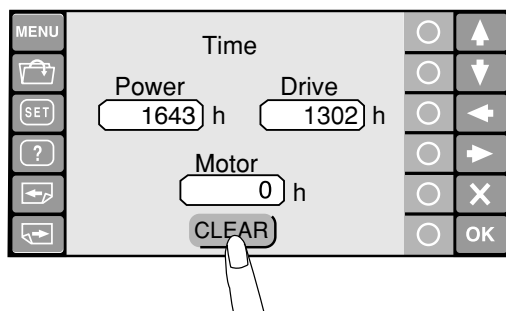
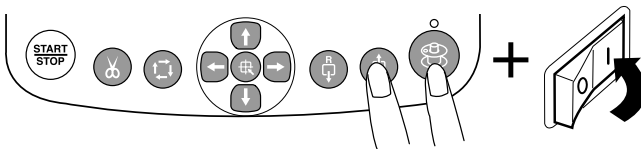



# Adjusting the Upper Shaft Timing

1. Remove the spool stand and right cover (see pages 4 and 6).

2. Open the factory adjusting menu window and press the **Phase** key to open the **Phase Sensor** adjusting window.

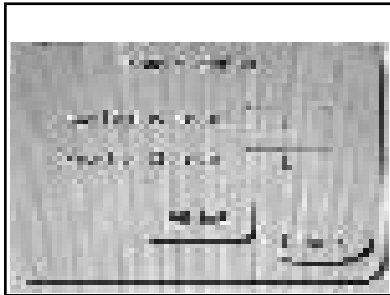

3. Turn the handwheel clockwise. The indication next to **Bottom dead pt.** should change from “L” to “H” when the index disk is set at 0° (L).

To adjust the bottom dead point (lowest position of the needle) timing, loosen the setscrew on the lowest position shield plate and turn it clockwise until the indication changes from “L” to “H”. Tighten the set screw.

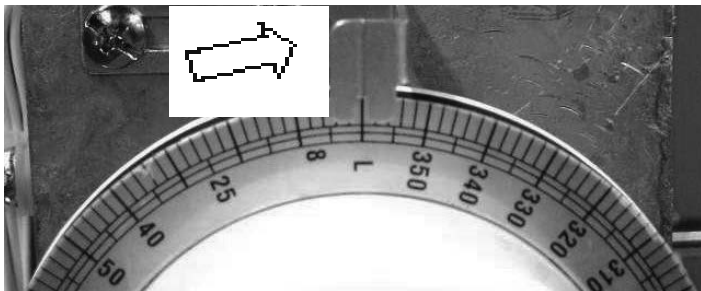

4. Turn the handwheel clockwise. The indication next to **Needle Change** should change from “L” to “H” when the index disk is set at 270°.

To adjust the needle change position timing, loosen the setscrew on the C point (needle change) shield plate and turn it clockwise until the indication changes from “L” to “H”. Tighten the setscrew.

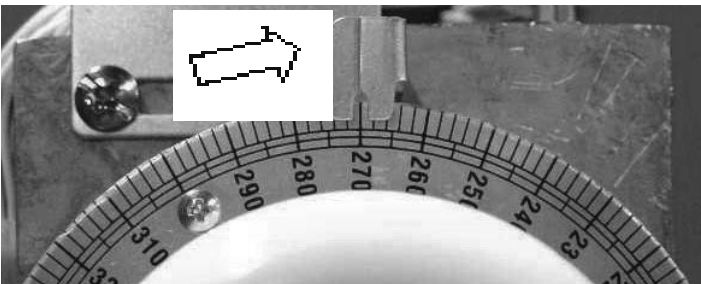

**NOTE:**

The shield plates should not interfere with the sensors.

5. Attach the parts removed in step 1.

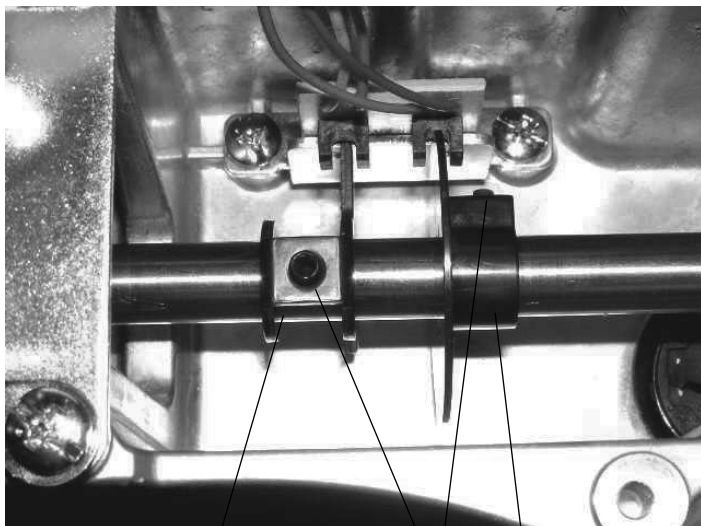

Bottom dead point (lowest position) shield plate

Setscrews

C point (needle change) shield plate

# Adjusting the Moving Head Stop Position

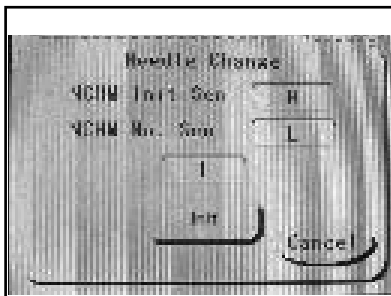

Lateral movement idler gear

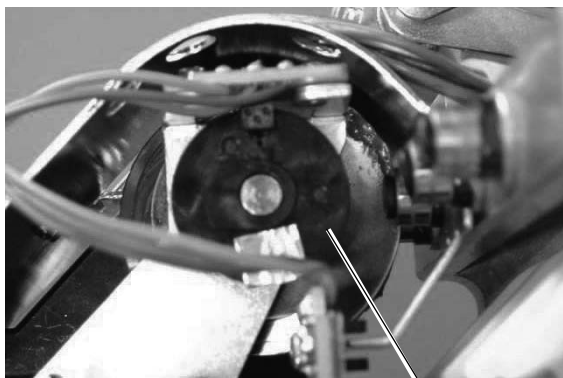
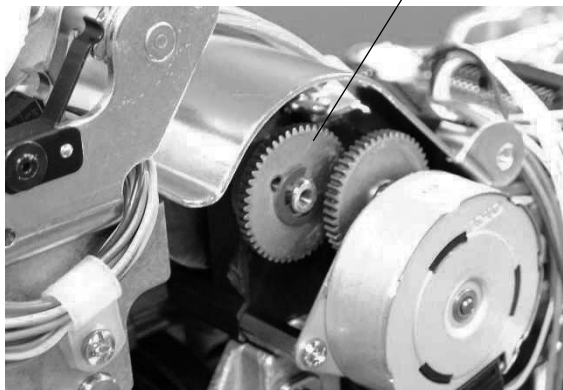

Stop position shield plate

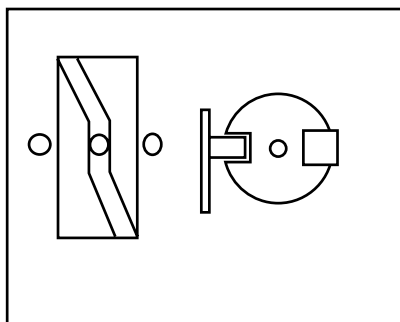

Phase reference of the lateral movement cam and stop position shield plate

Setscrew

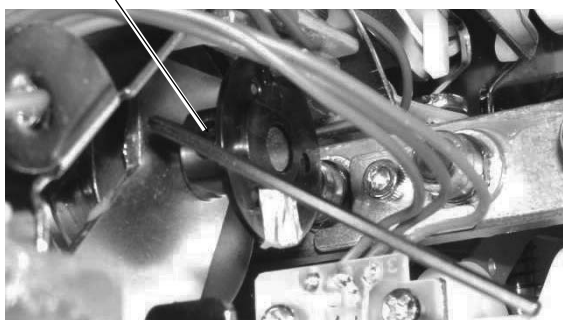

1. Remove the spool stand, right cover, left cover and tension control panel (see pages 4 – 6).
2. Open the factory adjusting menu window and press the **Needle** key to open the **Needle Change** adjusting window.
3. Turn the lateral movement idler gear to set the lateral movement cam at the middle of the flat portion. The indication next to **NCHM Init Sen** should be “**H**”. To adjust the stop position, loosen the setscrew and turn the stop positioning shield plate. Tighten the setscrew.

## NOTE:

The shield plate should not interfere with the sensor.

4. Press Init key to move the head to the stop position and check if “**L**” is indicated.
5. Attach the parts removed in step 1.

# Adjusting the Needle Stop Position

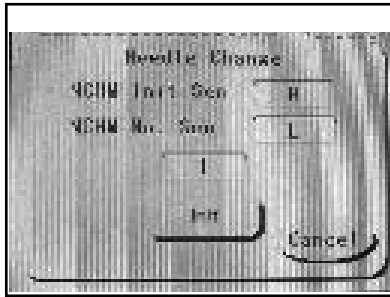

1. Remove the spool stand, right cover, left cover and tension control panel (see pages 4 – 6).
2. Turn the lateral movement idler gear to select needle bar No. 1.
3. Open the factory adjusting menu window and press the **Needle** key to open the **Needle Change** adjusting window.
4. Loosen the two setscrews.
5. Move the needle stop sensor to the left until the indication next to **NCHM No. Sen** turns "H".
6. Move the needle stop sensor slowly to the right until the indication next to **NCHM No. Sen** turns "L". Tighten the setscrews.

## NOTE:

The sensor should not interfere with the home position dog.

7. Attach the parts removed in step 1.

Lateral movement idler gear

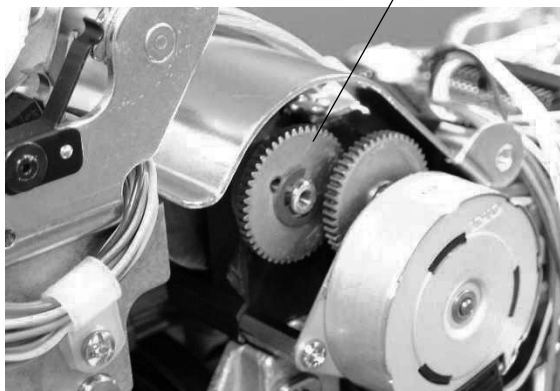

Home position dog

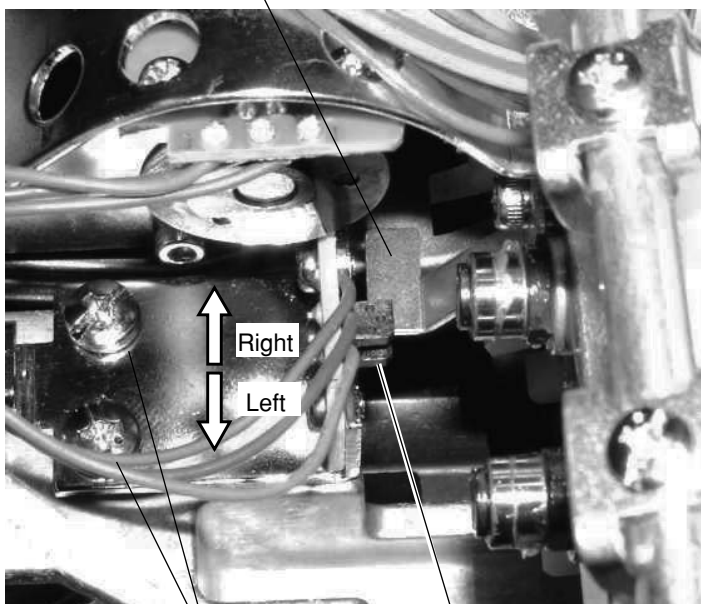

Setscrews

Needle stop sensor

# Adjusting the Carriage Home Position

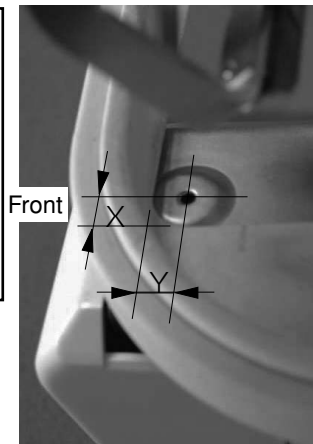
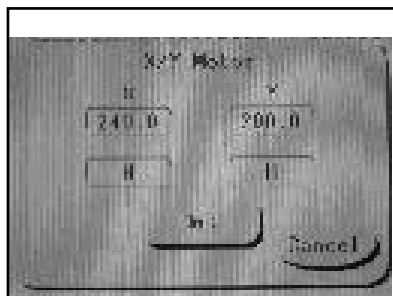

1. Remove the spool stand, right cover, left cover, base cover and X-carriage cover (see pages 4 – 7).
2. Attach the Hoop M1 (MB Hoop 240 X 200) to the hoop supporter.
3. Open the factory adjusting menu window and press the **X/Y Motor** key to open the **X/Y Motor** adjusting window.
4. Press the jog buttons to move the carriage to where the center of the hole in the needle plate is positioned 7 mm by 5 mm from the bottom left corner of the inner sides of the hoop.



5. Loosen the two setscrews (A) slightly. Move the Y-carriage sensor plate slowly to the front until the indication under **Y** changes from "H" to "L". Tighten the two setscrews (A).

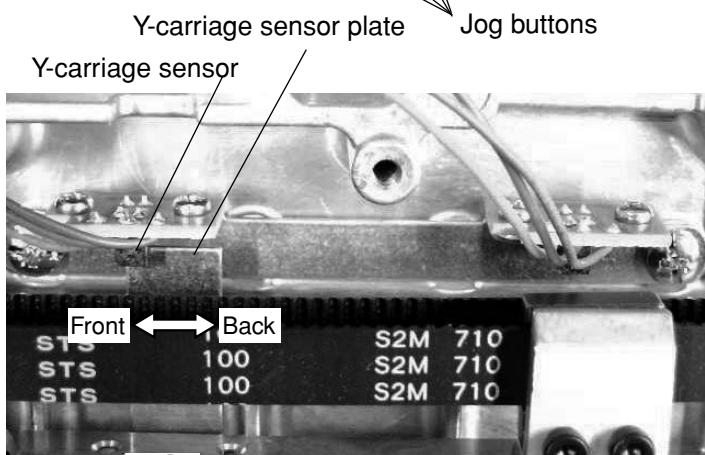

6. Loosen the two setscrews (B) slightly. Move the X-carriage sensor plate slowly to the left until the indication under **X** changes from "H" to "L". Tighten the two setscrews (B).

**NOTE:**

The sensors should not interfere with the carriage.

7. Attach the parts removed in step 1.

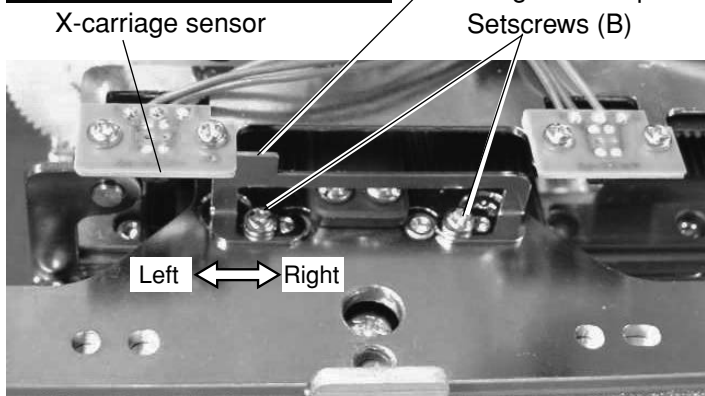
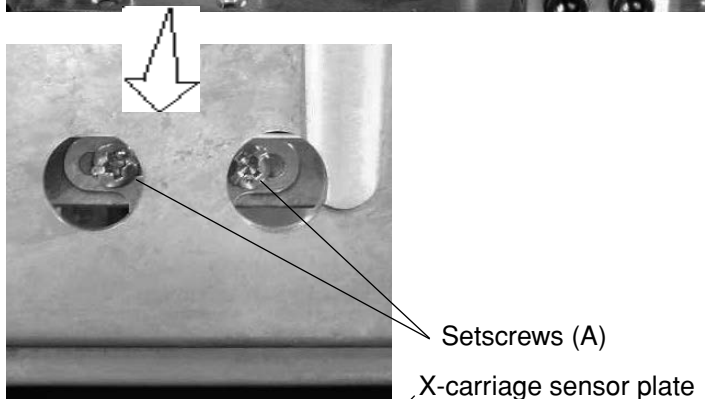

# **PARTS LIST**

# PARTS LIST

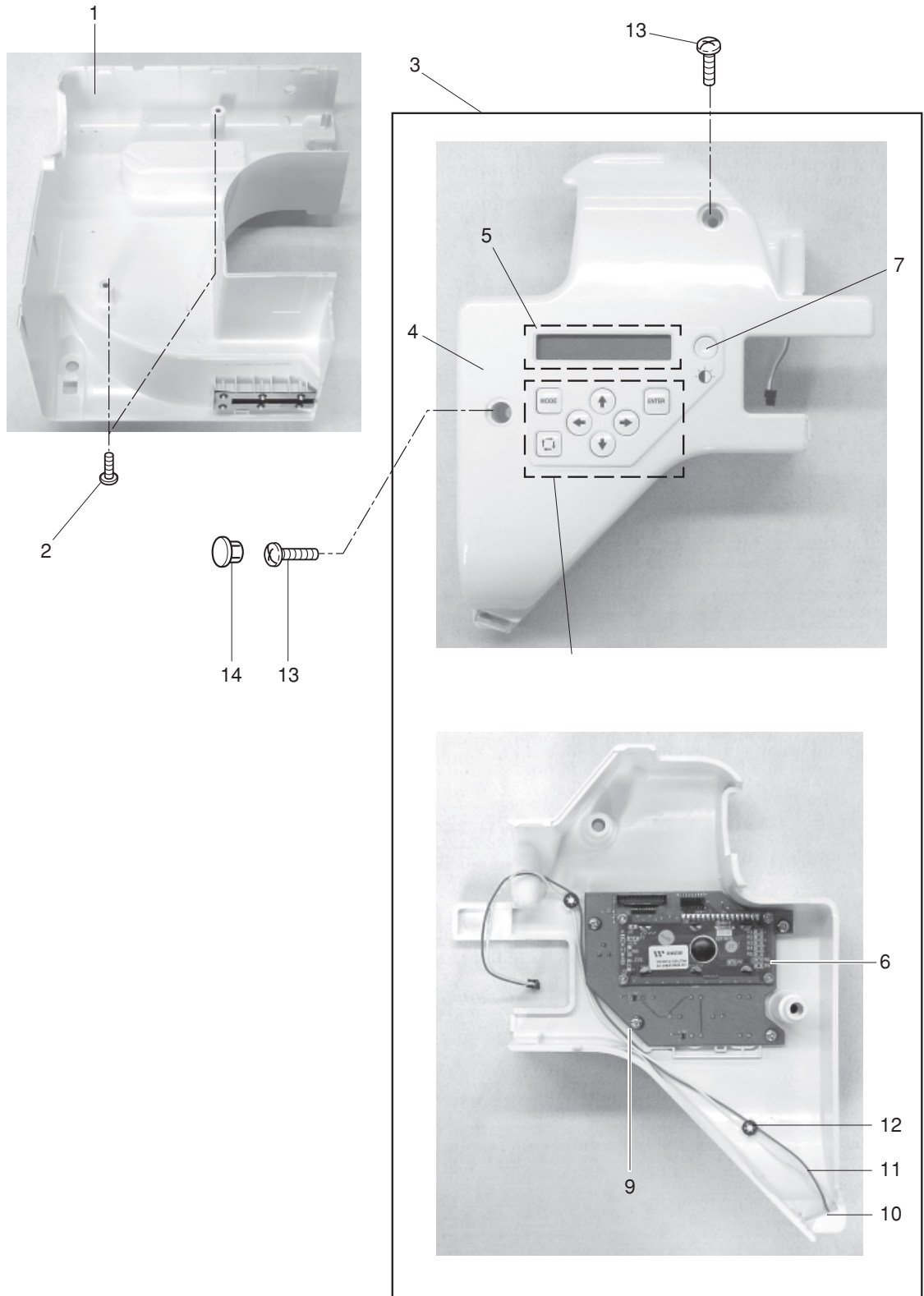

## PARTS LIST

---

KEY NO.	PARTS NO.	DESCRIPTION
1	770611008	Right cover (unit)
2	000081016	Setscrew 4x8
3	770608002	Head set right cover (unit)
4	770007108	Head set right cover
5	770418003	LCD window
6	770526016	Printed circuit board K (unit)
7	770397016	Brightness adjusting dial
8	770328108	Button panel
9	000216001	Setscrew 3x8 (B)
10	770335005	LED lamp cover
11	860576208	Printed circuit board L2 (unit)
12	000014306	Snap ring CS 3
13	000104119	Setscrew 4x20
14	653006101	Cap

---

# PARTS LIST

1

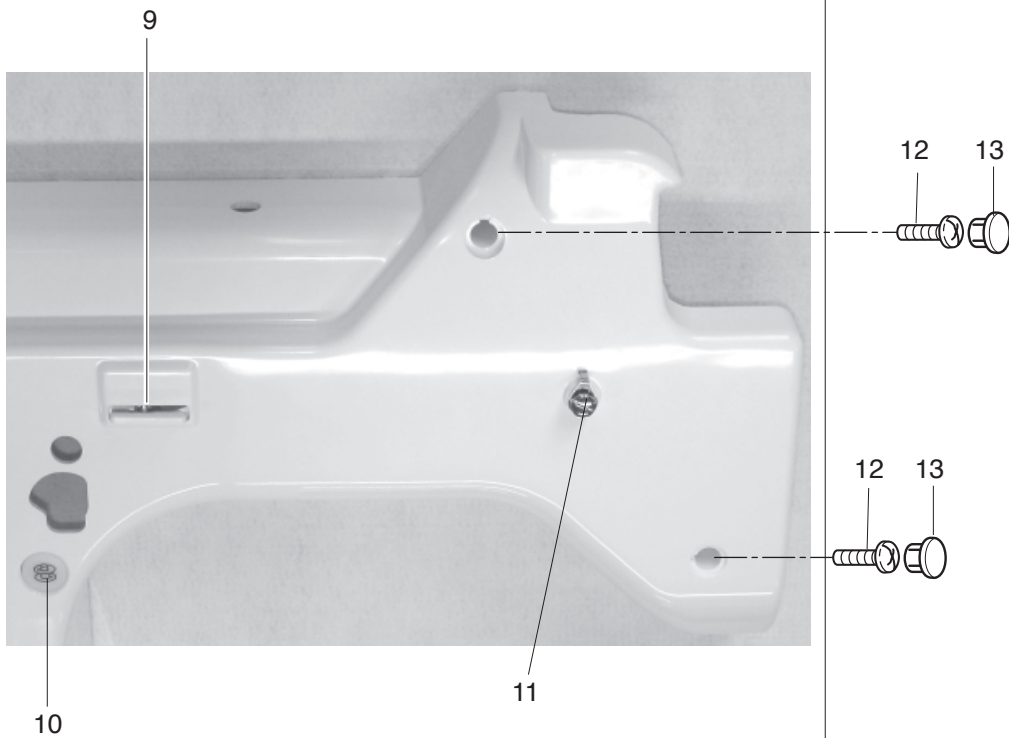
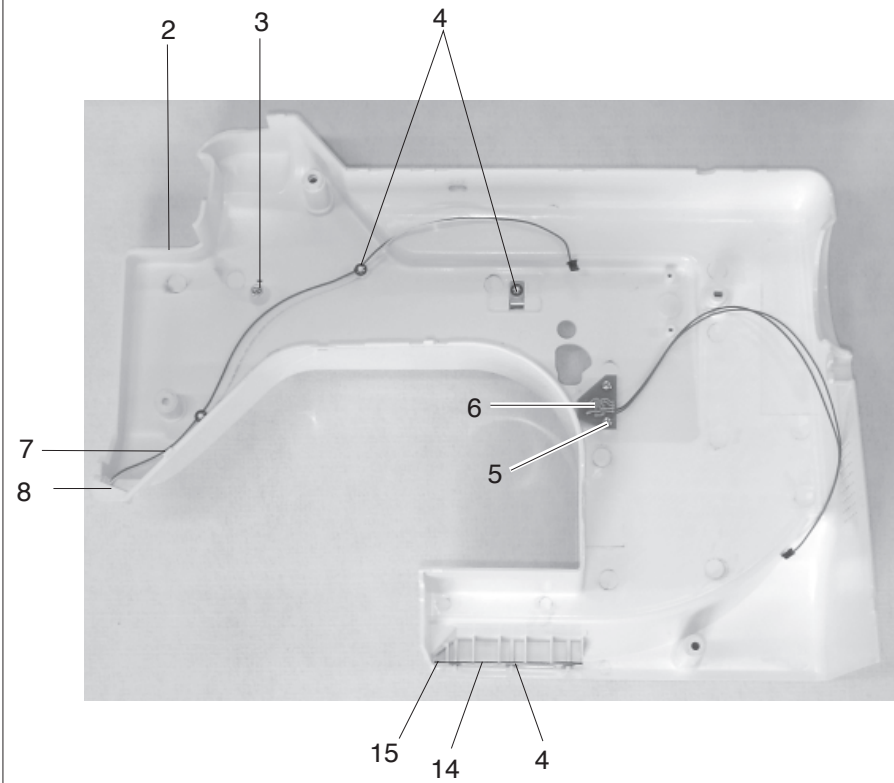



## PARTS LIST

---

KEY NO.	PARTS NO.	DESCRIPTION
1	770606011	Left cover (unit)
2	770005014	Left cover
3	000160102	Adjustable lock nut 4
4	000014306	Snap ring CS 3
5	000261001	Setscrew 3x8 (B)
6	770536008	Printed circuit board T (unit)
7	860576208	Printed circuit board L2 (unit)
8	770335005	LED lamp cover
9	832508006	Thread cutter (unit)
10	770343202	Start/Stop button
11	767639002	Thread guide (unit)
12	000101703	Setscrew 4x12
13	653006101	Cap
14	770332002	Carriage window sheet
15	770331001	Sheet set plate

---

PARTS LIST

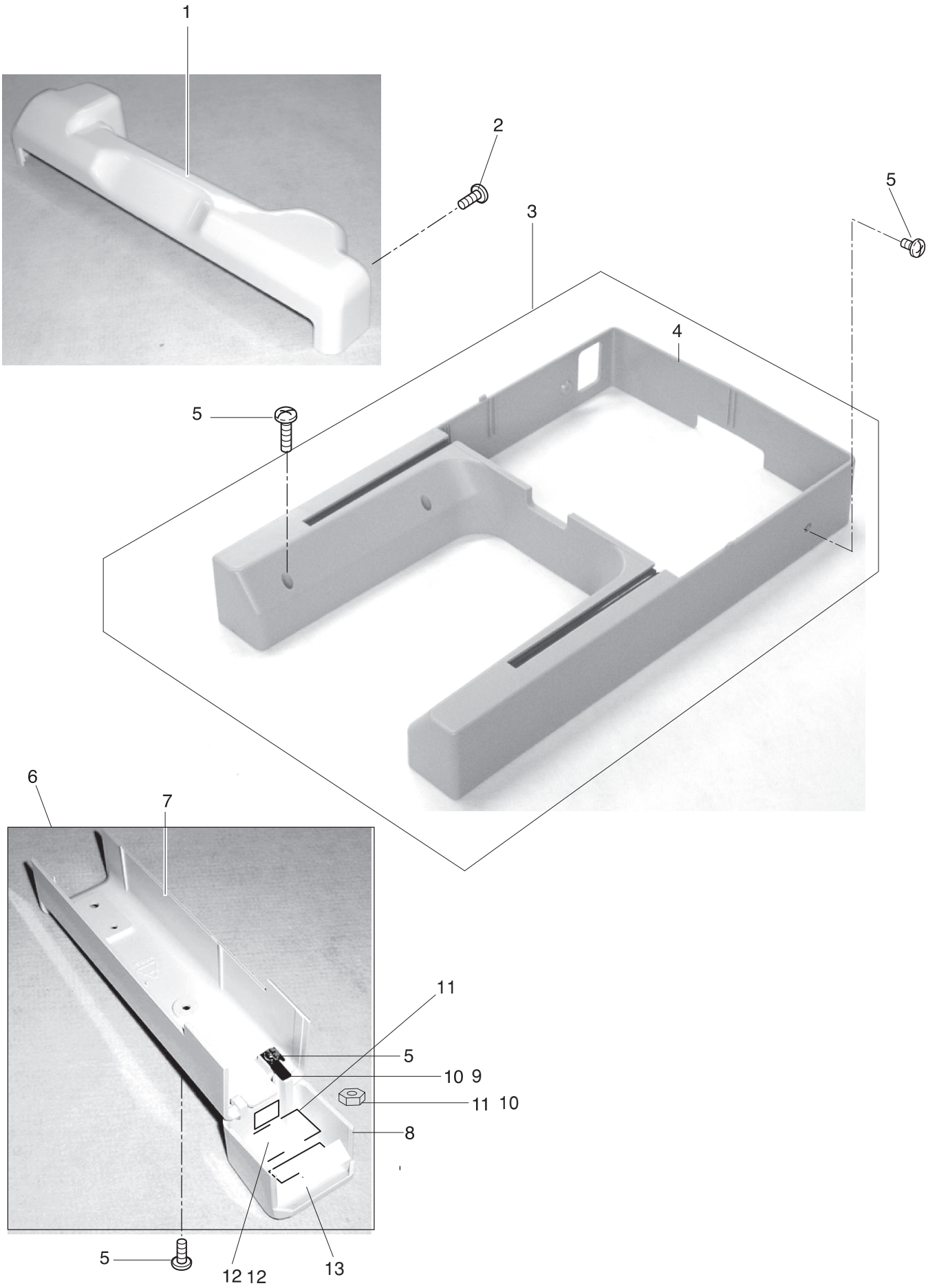

## PARTS LIST

KEY NO.	PARTS NO.	DESCRIPTION
1	770008006	X carriage cover
2	000101426	Setscrew 4x6
3	770612205	Base cover (unit)
4	770012209	Base cover
5	000081016	Setscrew 4x8
6	770605009	Bed cover (unit) (U.S.A.)
	770605102	Bed cover (unit) (Australia, Chile)
	770605205	Bed cover (unit) (Rotterdam Warehouse)
	770605401	Bed cover (unit) (Canada)
7	770014005	Bed cover
8	770015006	Hook race cover
9	770016007	Bed cover spring
10	000061113	Hexagonal nut 4
11	770425003	Oil hole seal
12	770434005	Sticker
13	830312016	Caution sticker (U.S.A.)
	100083000	Caution sticker (Canada)
	831025001	Caution sticker (Rotterdam Warehouse)

# PARTS LIST

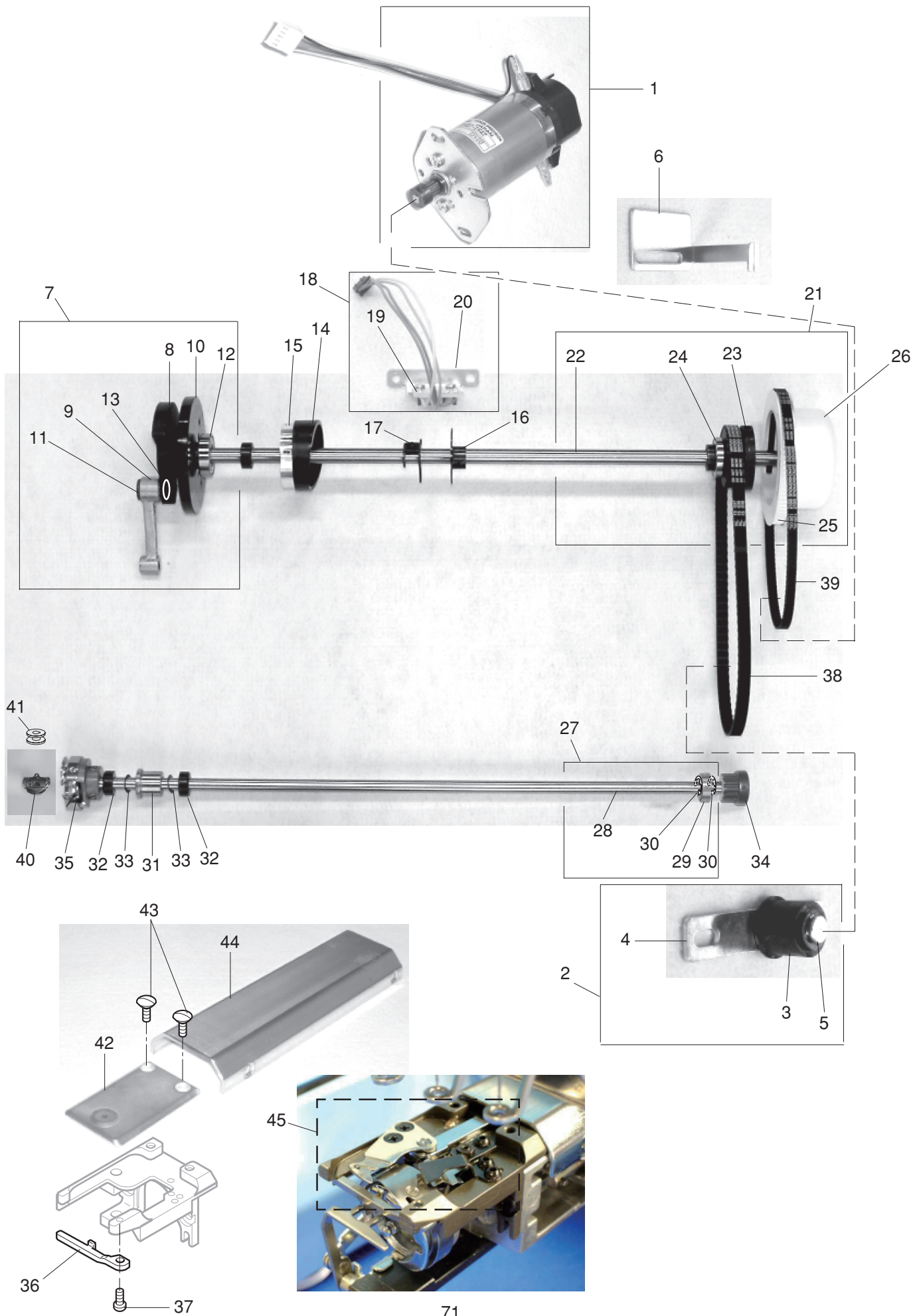

## PARTS LIST

KEY NO.	PARTS NO.	DESCRIPTION
1	770610007	DC motor (unit)
2	770625005	Idler (unit)
3	625217100	Idler
4	770023007	Tension
5	000002806	Ring E
6	770025009	Pointer
7	770628008	Crank (unit)
8	770067003	Crank
9	770502005	Crank rod (unit)
10	770376008	Presser foot cam
11	770068004	Rod shaft (upper)
12	770029003	Bearing
13	000131403	Rulon washer
14	770093008	Thread take-up lever cam
15	770094009	Cam clamp
16	770149000	Point Slit C
17	653052009	Shielding plate (A)
18	770675008	Sensor (unit)
19	843505708	Printed circuit board P (unit)
20	770148009	Sensor set plate
21	770627007	Upper shaft (unit)
22	770019000	Upper shaft
23	770021005	Upper shaft pulley
24	770027001	Bearing
25	770422000	Belt wheel
26	770423001	Handwheel
27	770632005	Hook race shaft (unit)
28	770030007	Hook race shaft
29	767182005	Spherical bushing
30	000032403	Crescent ring
31	770368007	Hook race shaft front bushing
32	820672005	Lower shaft ring (unit)
33	000036902	Thrust washer
34	770022006	Hook race pulley
35	770589006	Hook race (unit)
36	770033000	Shuttle hook holder
37	770498007	Button head cap bolt
38	770028002	Timing belt
39	846188102	Timing belt
40	770590000	Bobbin case (unit)
41	770591001	Bobbin
42	770034012	Needle plate (flat seam)
43	770370002	Needle plate set screw
44	770035002	Bed face plate
45	770501004	Thread cutter (unit)

# PARTS LIST

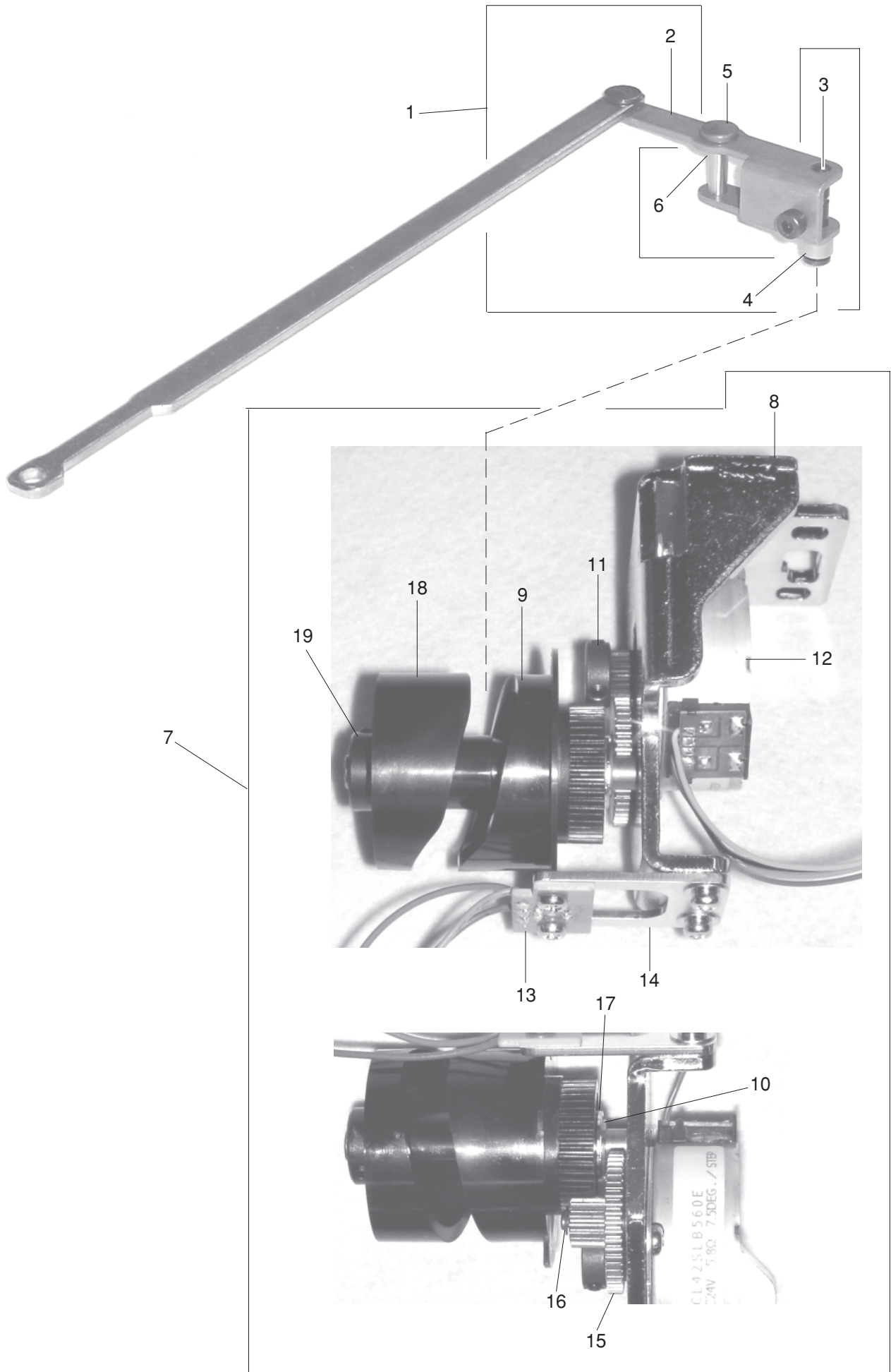

## PARTS LIST

---

KEY NO.	PARTS NO.	DESCRIPTION
1	770635008	Lever (unit)
2	770056009	Lever unit
3	770053006	Roller shaft
4	770054007	Roller
5	770055008	Support pin
6	000036603	Thrust washer
7	770634007	Thread cutter driving (unit)
8	770048008	Thread cutter driving base
9	770374006	Thread cutter cam (right)
10	000001609	Snap ring E 5
11	770137005	Driving gear
12	770539207	Pulse motor
13	843503119	Printed circuit board E2 (unit)
14	770051004	Sensor set plate
15	770057000	Y gear
16	000002301	Snap ring E 2
17	770058001	Cam base
18	770375007	Thread cutter cam (left)
19	770049009	Cam holder collar

---



PARTS LIST

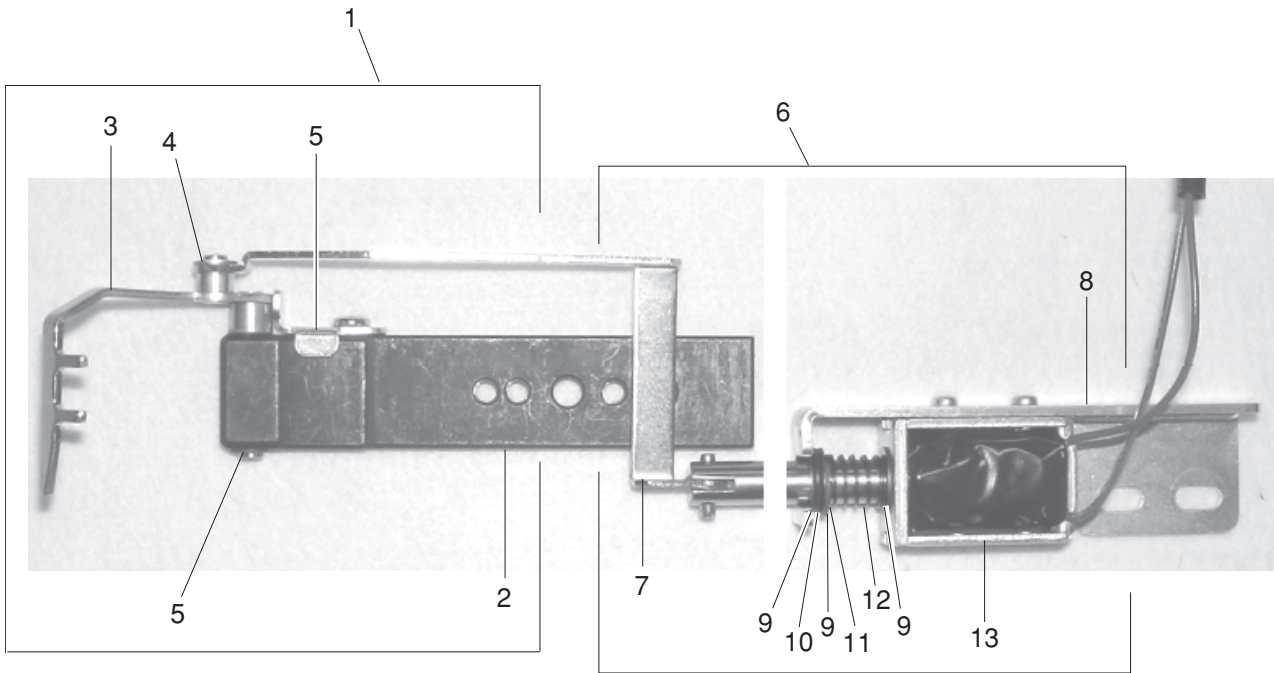



## PARTS LIST

---

KEY NO.	PARTS NO.	DESCRIPTION
1	770636009	Keeper (unit)
2	770062008	Keeper base
3	770061007	Keeper
4	000002116	Snap ring E 3
5	770063009	Stopper
6	770637000	Keeper solenoid (unit)
7	770060006	Keeper rod
8	770059002	Solenoid base
9	000036108	Thrust washer
10	770450007	Ring O
11	000001609	Snap ring E 5
12	770065001	Solenoid spring
13	770066002	Keeper solenoid (unit)

---

# PARTS LIST

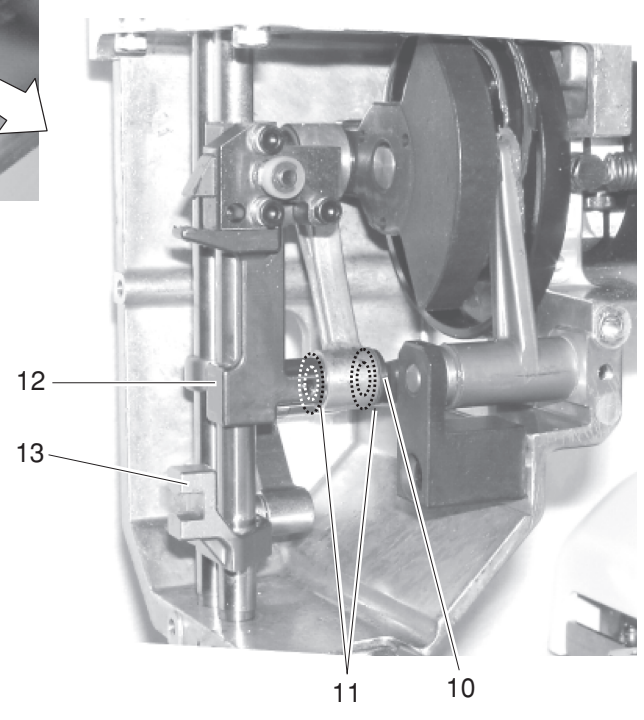
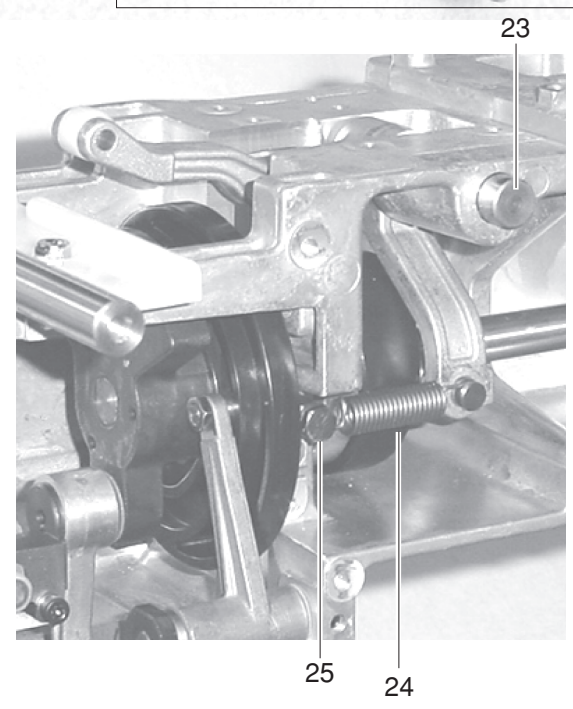
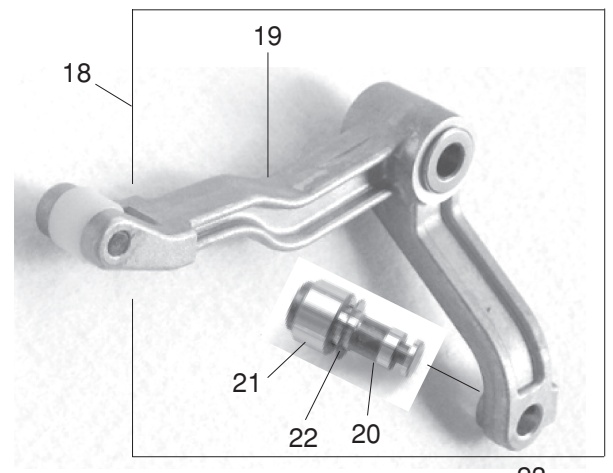
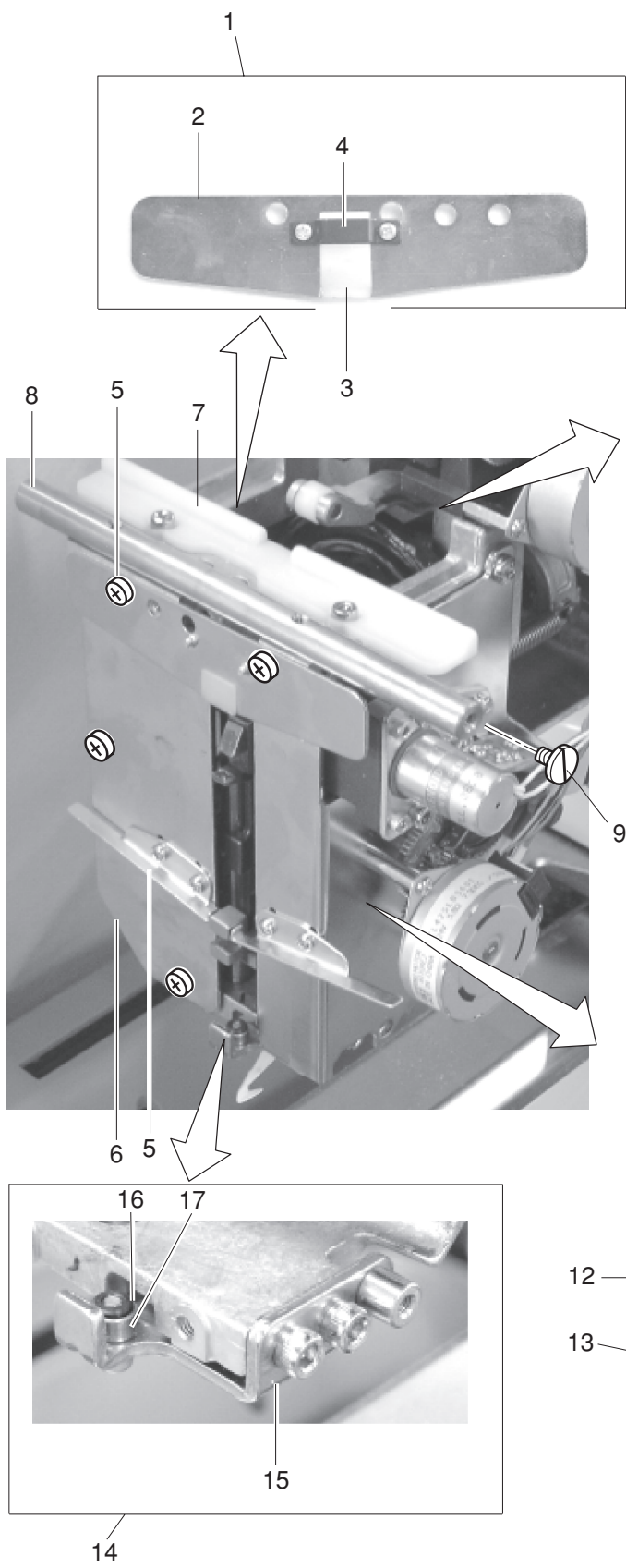

## PARTS LIST

KEY NO.	PARTS NO.	DESCRIPTION
1	770642008	Upper face plate (unit)
2	770113005	Upper face plate
3	770116008	Cushion B
4	770117009	Supporting metal
5	770132000	Left guide plate
6	770107006	Left face plate
7	770081003	Thread take-up lever guide
8	770082004	Rail shaft
9	770115007	Stopper screw
10	770073002	Lower rod shaft
11	000131506	Rulon washer
12	770638001	Needle bar rest (unit)
13	770639002	Presser foot block (unit)
14	770641007	Needle drop adjusting (unit)
15	770095000	Needle drop adjusting plate (unit)
16	770096001	Adjusting shaft
17	770097002	Adjusting roller
18	770629009	Thread take-up lever (unit)
19	770504007	Thread take-up lever (unit)
20	770089001	Cam roller shaft
21	770090005	Cam roller
22	000036005	Thrust washer
23	770086008	Thread take-up lever supporting shaft
24	770091006	Thread take-up lever spring
25	770092007	Thread take-up lever spring holding shaft
26	000081016	Setscrew 4x8

# PARTS LIST

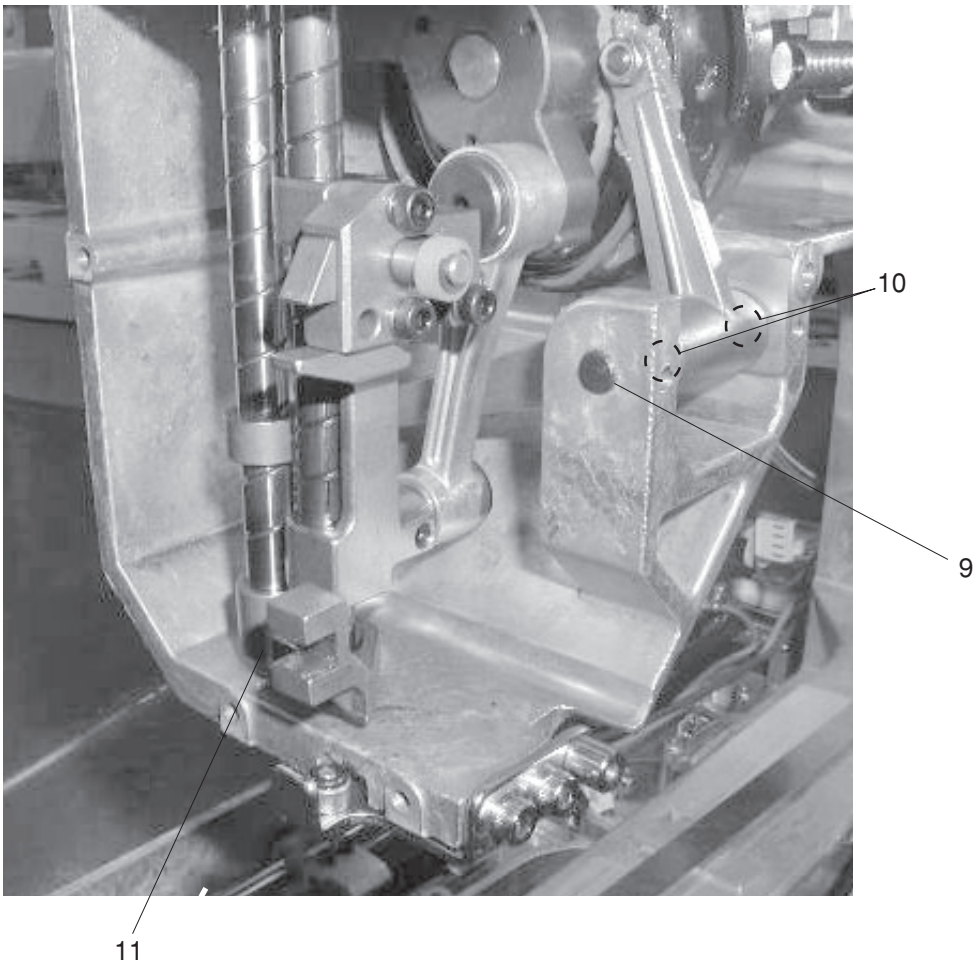
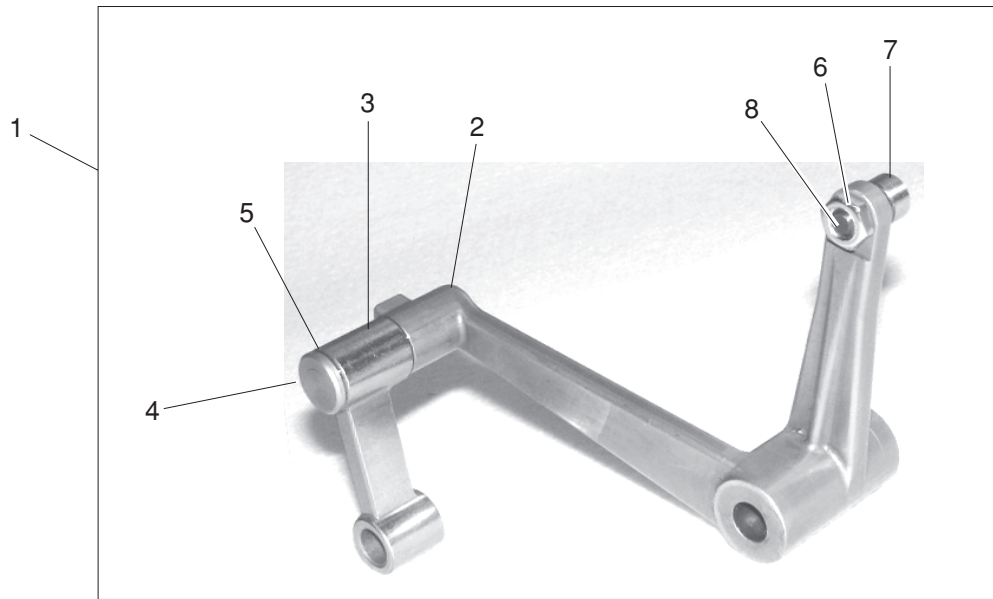

## PARTS LIST

---

KEY NO.	PARTS NO.	DESCRIPTION
1	770630003	Presser foot lever (unit)
2	770120005	Presser foot lever
3	770125000	Presser foot rod
4	770126001	Rod shaft
5	000036005	Thrust washer
6	000061205	Nut 4-3-7
7	770121006	Cam roller
8	770122007	Roller pin
9	770340003	Supporting shaft
10	000131506	Rulon washer
11	770640006	Main shaft (unit)

---

# PARTS LIST

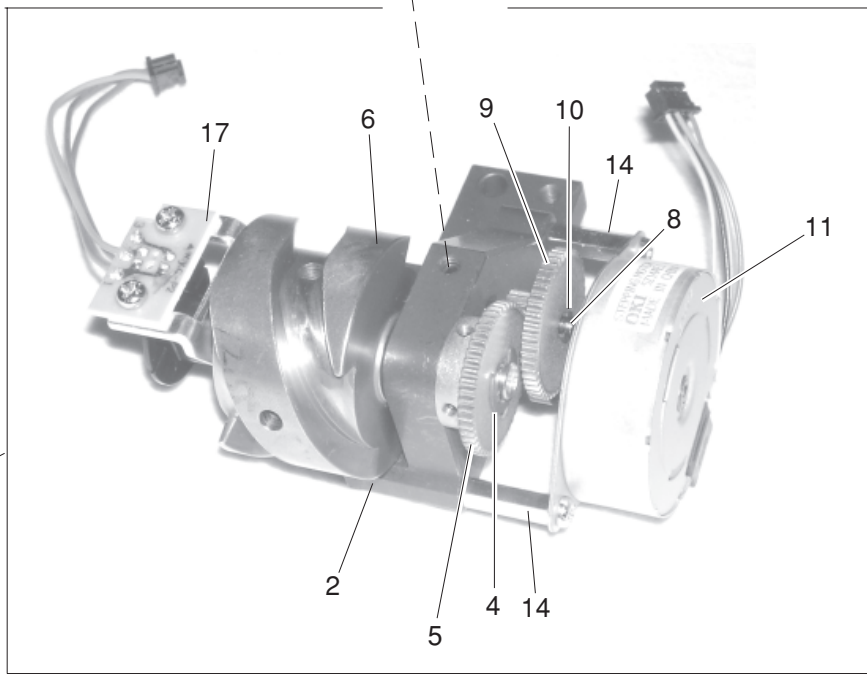
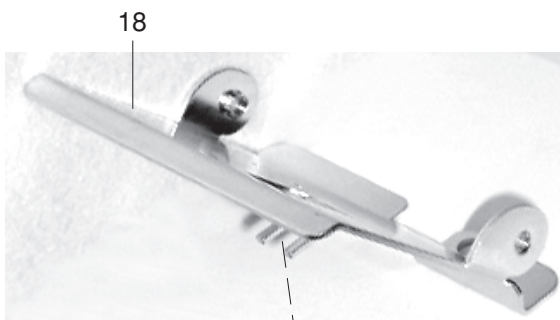
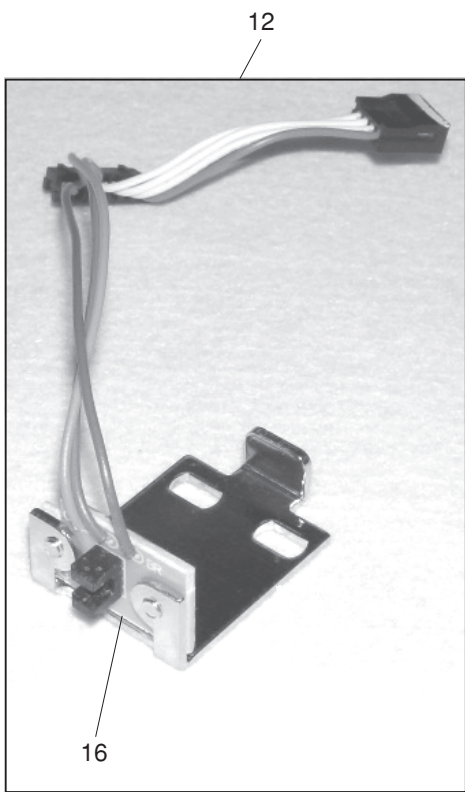
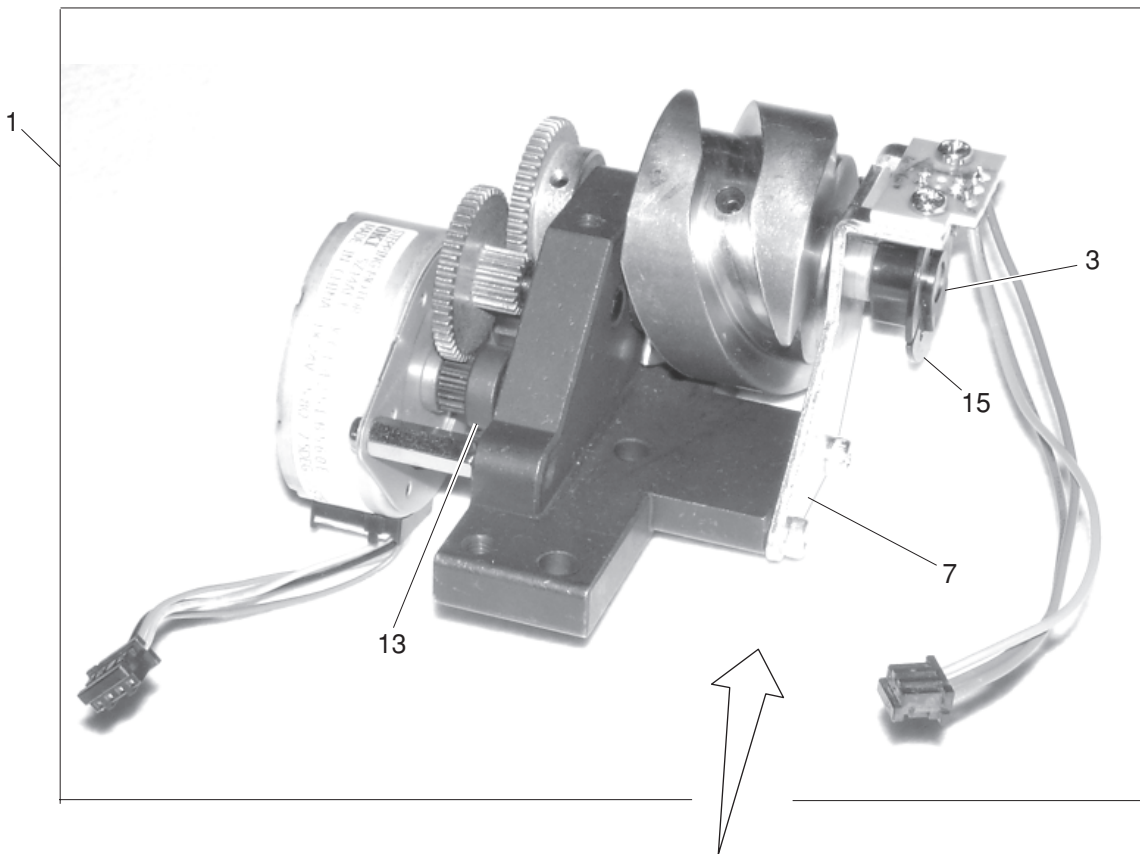

## PARTS LIST

KEY NO.	PARTS NO.	DESCRIPTION
1	770645001	Horizontal motor drive shaft (unit)
2	770133001	Horizontal base
3	770134002	Horizontal move drive shaft
4	000001609	Snap ring E 5
5	770135003	Horizontal gear B
6	770139007	Horizontal cam
7	770140001	Shaft guide plate
8	770146007	Center shaft
9	770136004	Idler gear
10	000002301	Snap ring E 2
11	770539207	Pulse motor
12	770676001	Needle position sensor
13	770137005	Horizontal motor gear
14	770138006	Motor stud
15	770142003	Needle position sensor slit
16	770564005	Motor harness (Horizontal) (unit)
17	843502303	Printed circuit board E1 (unit)
18	770147008	Driving motor cover



# PARTS LIST

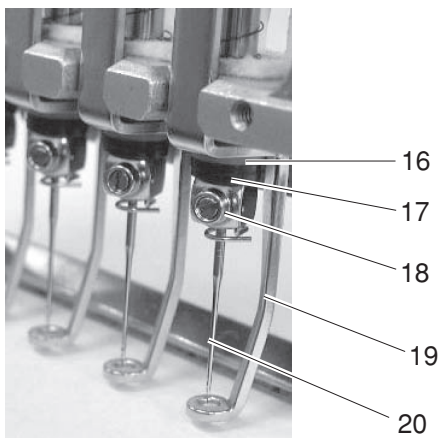
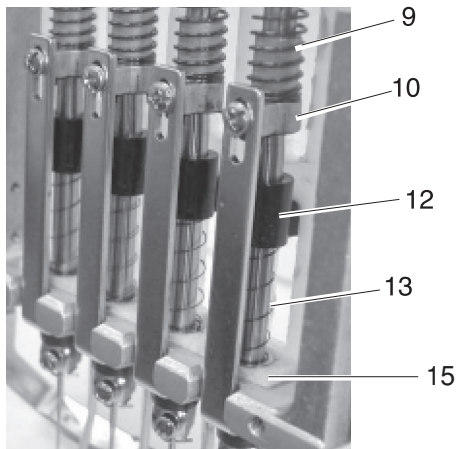
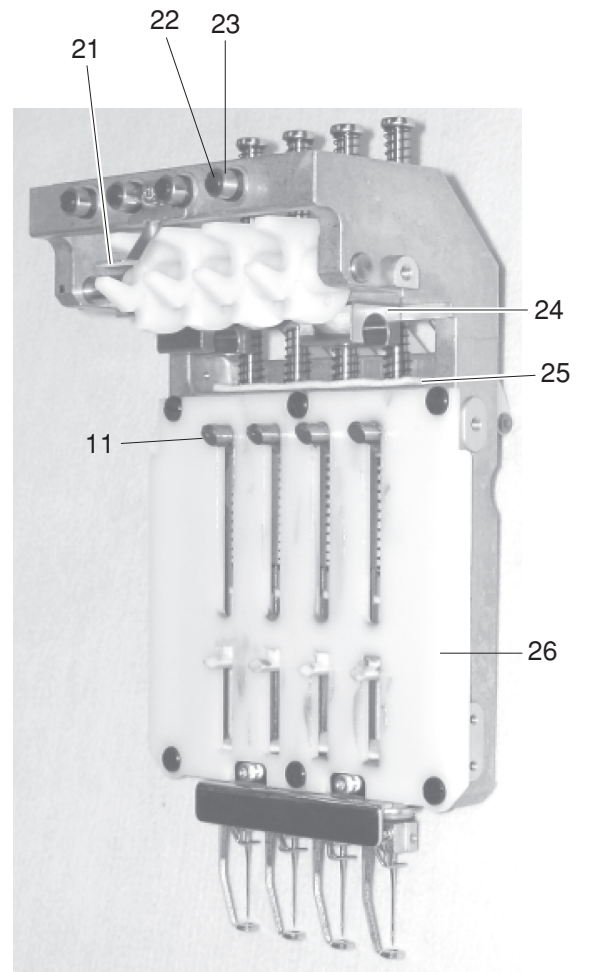
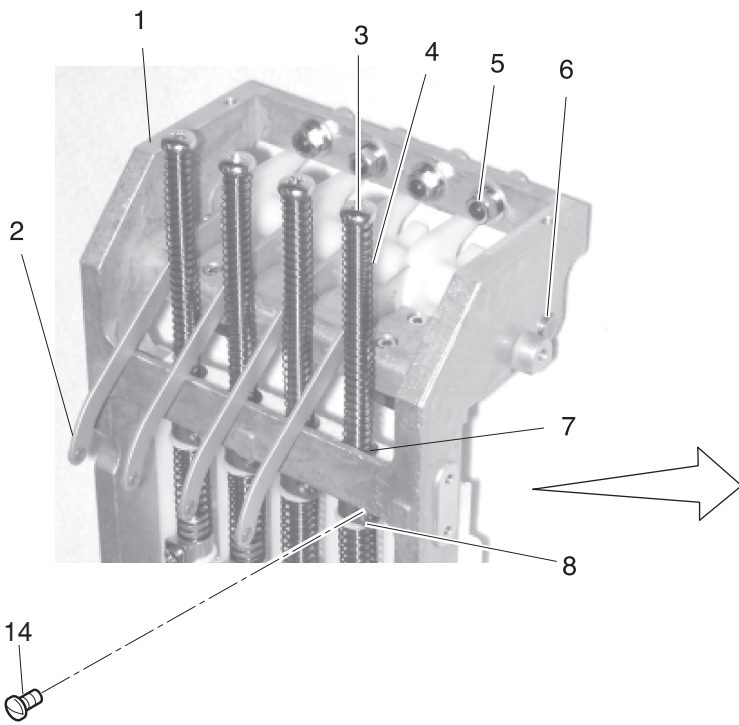



## PARTS LIST

KEY NO.	PARTS NO.	DESCRIPTION
1	770152006	Dynamic head case
2	770659008	Thread take-up lever (unit)
3	770163000	Needle bar
4	770162009	Needle bar supporting upper spring
5	770153007	Head drive pin
6	770157001	Thread take-up lever shaft
7	000070311	Washer 5
8	770168005	Spring cushion
9	770169006	Needle bar supporting lower spring
10	770179009	Presser foot release button
11	770166003	Needle bar supporter
12	770170000	Presser bar supporter
13	770181004	Presser bar return spring
14	770167004	Setscrew
15	770295002	Felt
16	770172002	Presser foot bushing
17	770173003	Needle clamp cushion
18	770509002	Needle clamp (unit)
19	770171001	Presser foot
20	770419004	Needle (#11)
21	770156000	Home position dog
22	770155009	Setscrew
23	770154008	Head drive roller
24	770161008	Head drive guide
25	770164001	Oil felt
26	770176006	Stopper

# PARTS LIST

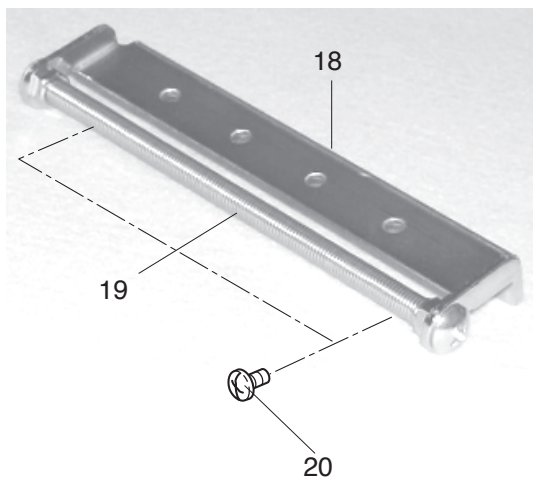
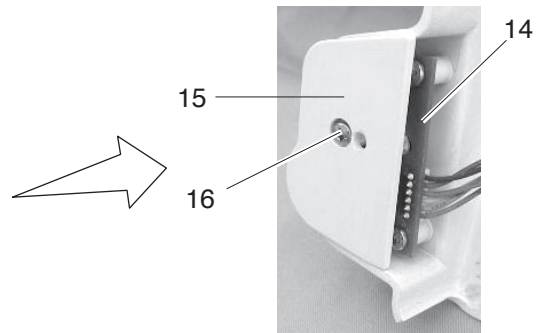
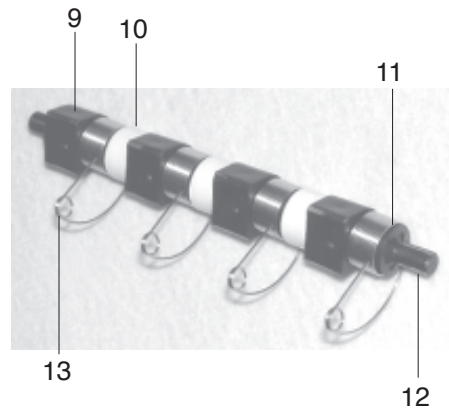
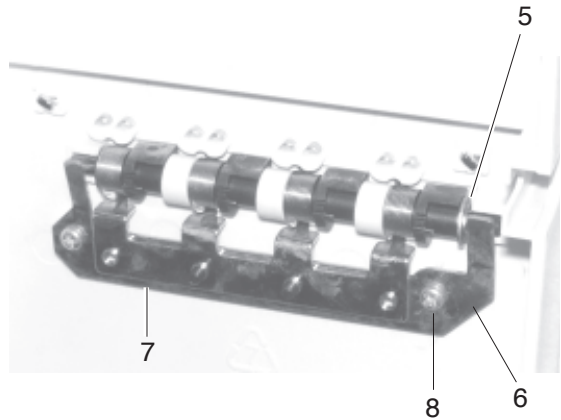
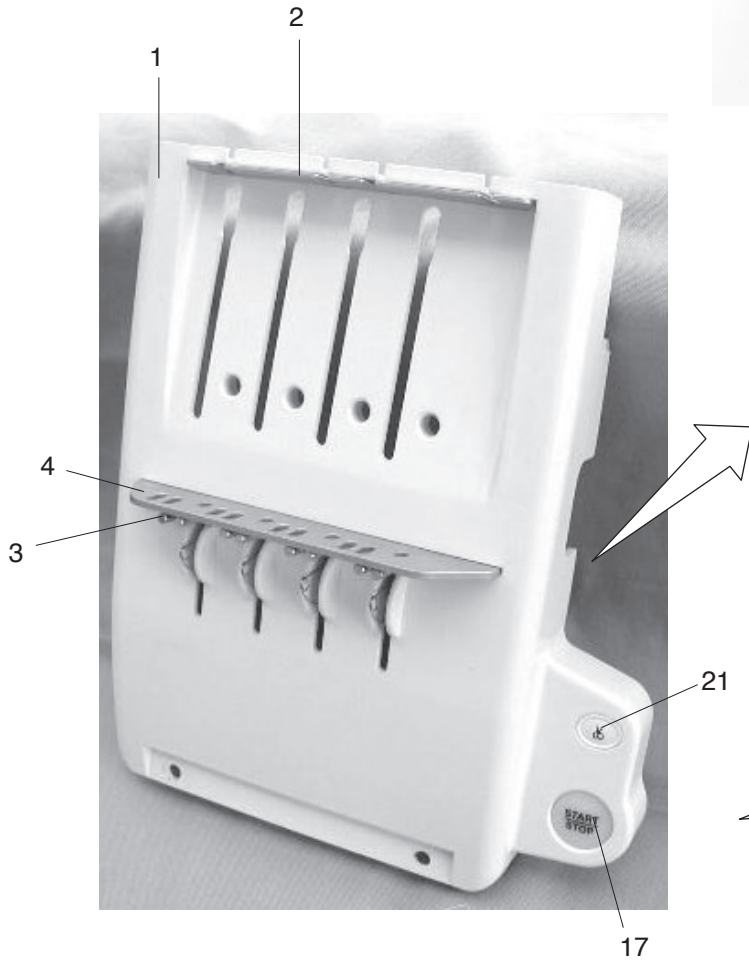

## PARTS LIST

KEY NO.	PARTS NO.	DESCRIPTION
1	770185A01	Thread catcher panel
2	770424002	Thread catcher upper guide plate
3	770187000	Needle thread support spring
4	770186009	Thread catcher guide plate
5	000002116	Snap ring E 3
6	770192008	Thread catcher set plate
7	770193009	Adjuster
8	000161103	Setscrew 3x6 (B)
9	770189002	Block
10	770190006	Block spacer
11	770447001	Snap ring SE 4
12	770191007	Thread catcher supporting shaft
13	770188001	Check spring
14	770535007	Printed circuit board S (unit)
15	770184007	Rear lid
16	000261001	Setscrew 3x8
17	770343109	Start/Stop button
18	770195001	Lower thread guide plate
19	770194000	Thread guide spring
20	000165901	Setscrew 4x12
21	770404109	Button 1

# PARTS LIST

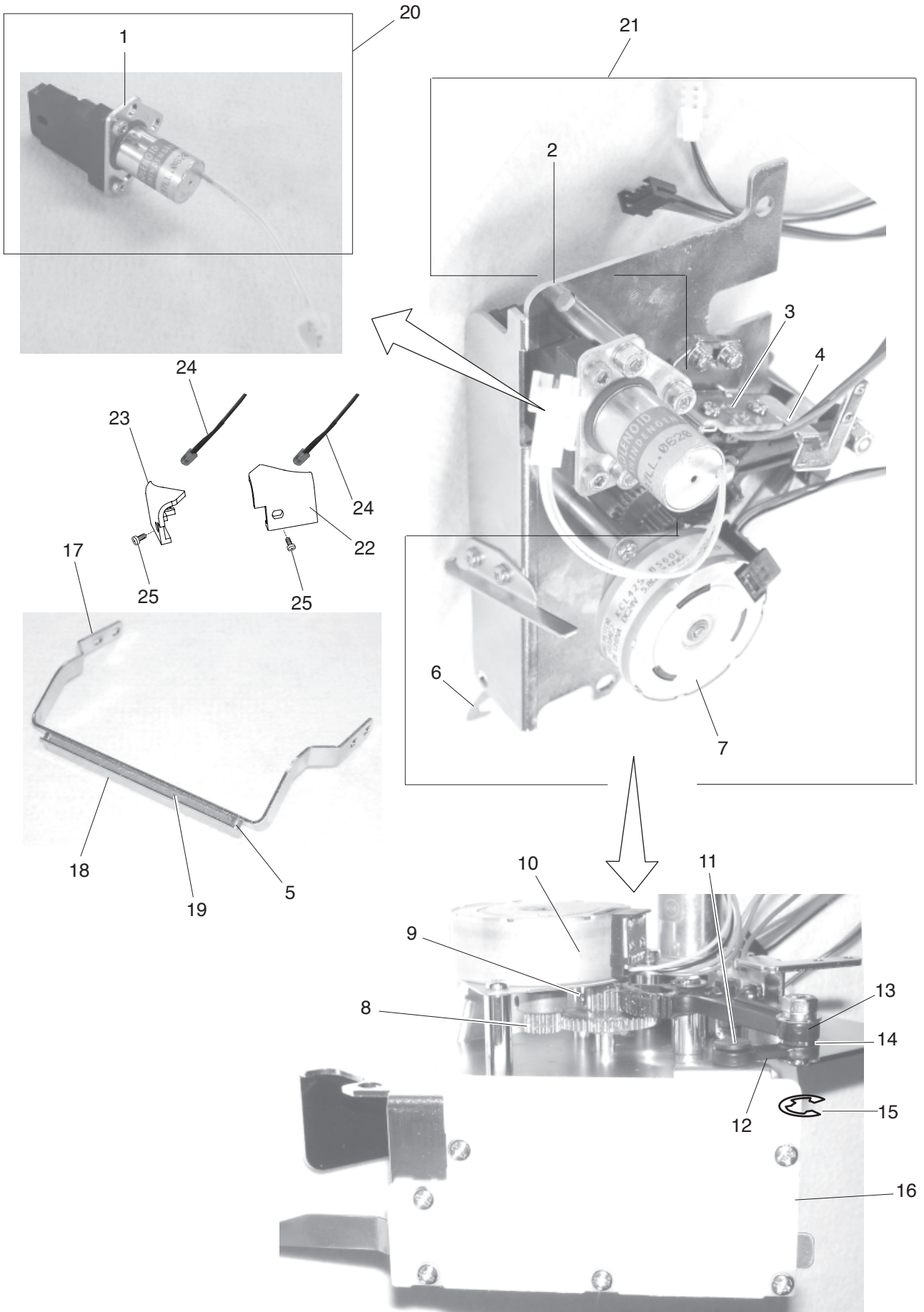

## PARTS LIST

KEY NO.	PARTS NO.	DESCRIPTION
1	770506009	Jump solenoid (unit)
2	770507000	Right face plate (unit)
3	770565006	Motor harness (unit)
4	770212005	Printed circuit board set plate
5	770215008	Spacer S
6	770210003	Thread catcher hook
7	770539207	Pulse motor (unit)
8	770204004	Horizontal motor gear A
9	770205005	Horizontal gear
10	000002301	Snap ring E 2
11	770209009	Thread catcher hook spring
12	770207007	Thread catcher connecting link
13	770206006	Thread catcher rod
14	770208008	Rod shaft
15	000002507	Snap ring E 4
16	770211004	Thread catcher guide
17	770213109	Thread catcher upper holder
18	770214007	Thread catcher lower holder
19	770216009	Thread guide brush
20	770631004	Needle bar rest remove (unit)
21	770643009	Thread catcher (unit)
22	770953005	LED cover (right)
23	770954006	LED cover (left)
24	770581008	LED (unit)
25	000101105	Setscrew 3x4

PARTS LIST

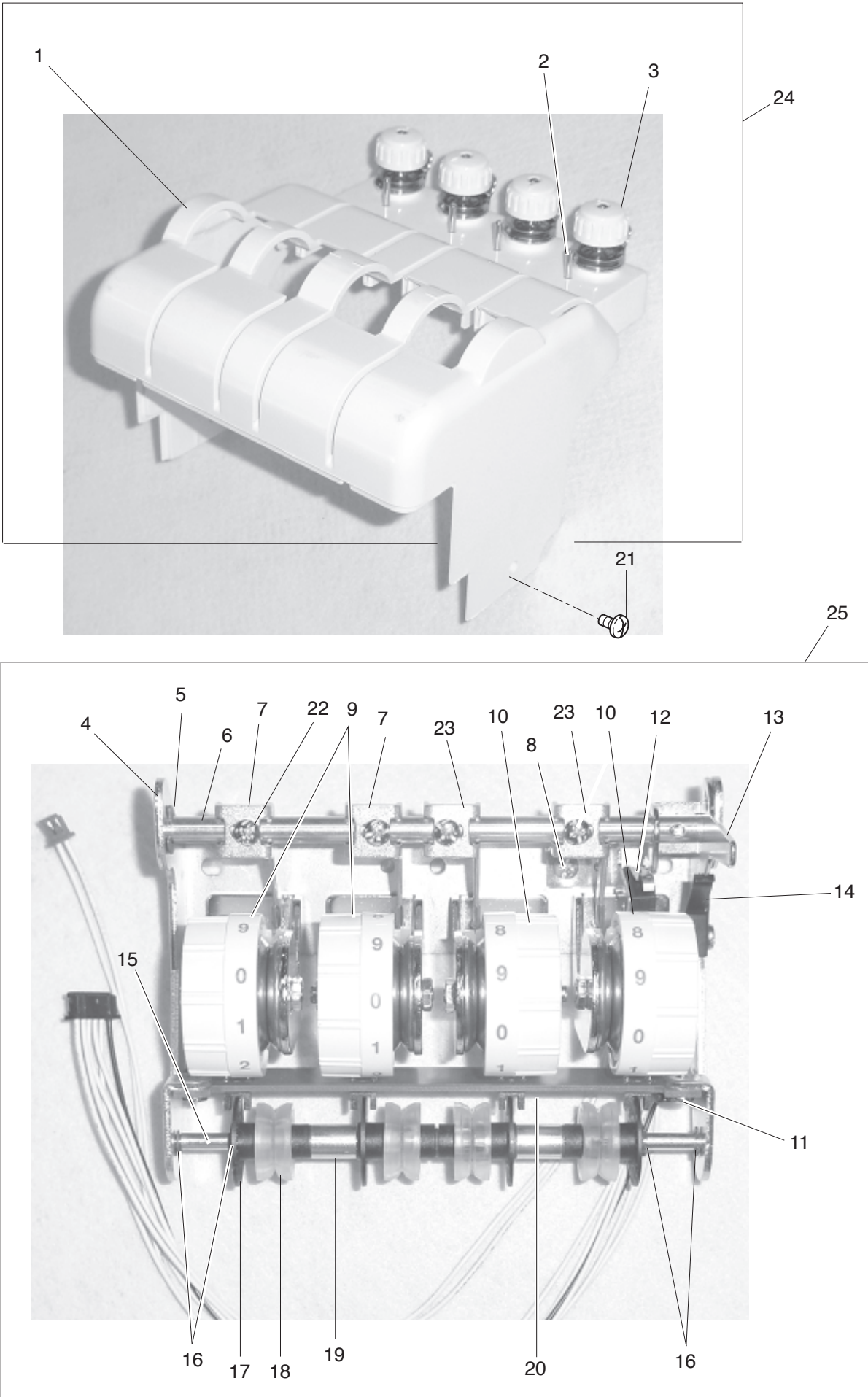

## PARTS LIST

KEY NO.	PARTS NO.	DESCRIPTION
1	770253008	Thread tension panel
2	770252007	Guide pin
3	770515001	Pretension (unit)
4	770236005	Thread tension bracket
5	000001609	Snap ring E 5
6	770250005	Release shaft
7	770243005	Thread release arm A
8	000103808	Setscrew 3x5
9	770512008	Thread tension A (unit)
10	770513009	Thread tension B (unit)
11	000101116	Setscrew 3x4
12	846513801	Micro switch (unit)
13	770245007	Thread tension release lever
14	770249001	Stopper spring
15	770240013	Sensor roller shaft
16	000002116	Snap ring E 3
17	770241003	Sensor slit
18	770242004	Sensor roller
19	770239019	Sensor spacer
20	770514000	Printed circuit board G (unit)
21	000166005	Setscrew 4x8
22	000066705	Setscrew 3x8
23	770244006	Thread release arm B
24	770613000	Thread tension panel (unit)
25	770602109	Thread tension (unit)



# PARTS LIST

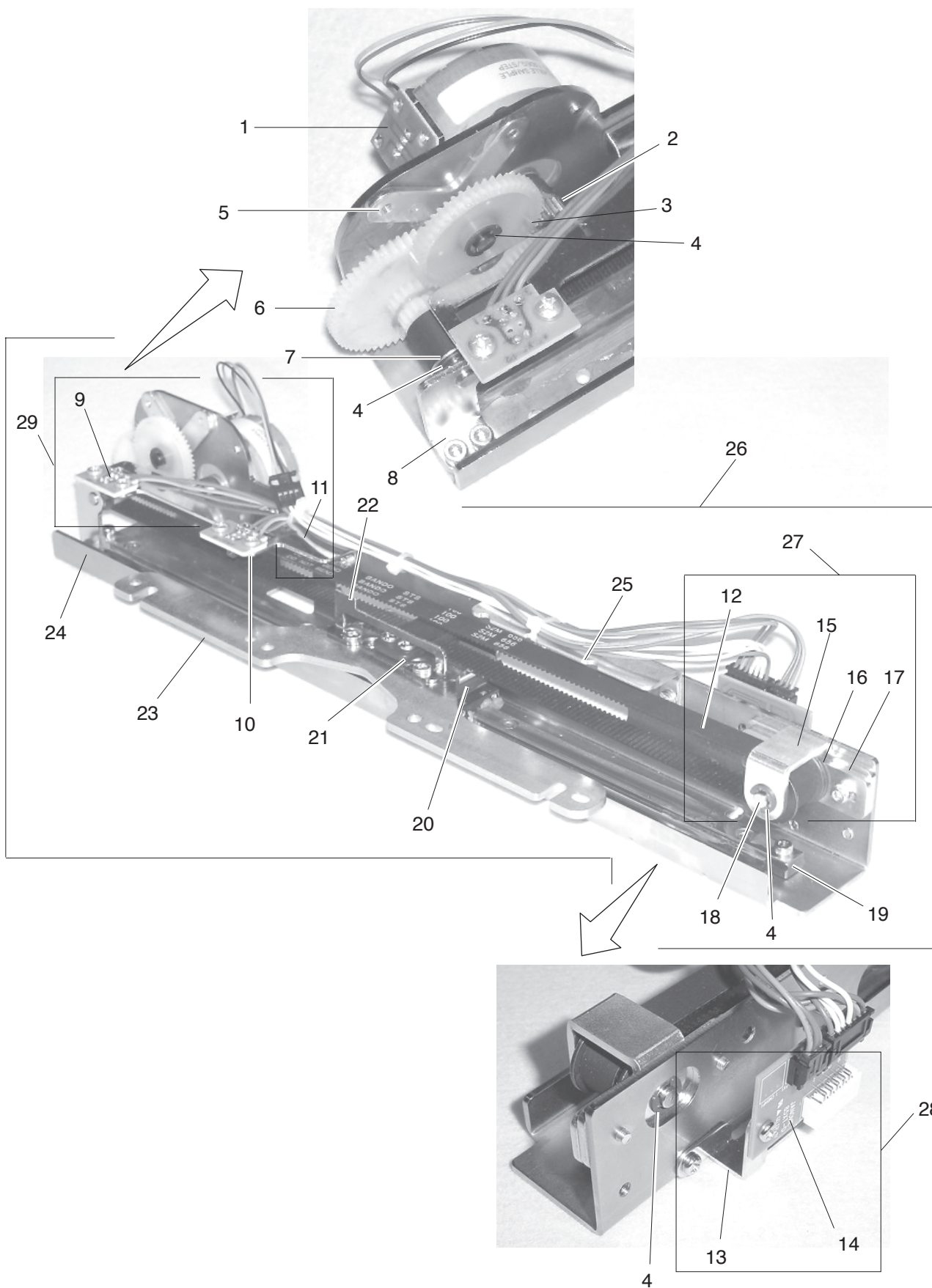



## PARTS LIST

KEY NO.	PARTS NO.	DESCRIPTION
1	770532004	Stepping motor
2	770379001	Motor gear
3	770380005	X gear
4	000002507	Snap ring E 4
5	850110106	X gear set plate
6	770262000	X drive pulley
7	000070311	Washer 5
8	770271002	X drive pulley shaft supporter
9	843502406	Printed circuit board E1 (unit)
10	770566007	Motor harness (unit)
11	770276007	X sensor set plate
12	770280004	X timing belt
13	770270001	Printed circuit board bracket 1
14	770533005	Printed circuit board D (unit)
15	770277008	X tension pulley plate
16	770528007	Tension pulley (unit)
17	770438009	Pulley spacer
18	770278009	X tension pulley shaft
19	770269007	X rail (LM guide)
20	770268006	LM connecting block
21	770264002	X belt foot
22	770265003	X carriage sensor plate
23	770267005	Connecting plate
24	770518004	X carriage base (unit)
25	770442006	Bracket
26	770646002	X carriage base (unit)
27	770649005	X tension pulley (unit)
28	770648004	Printed circuit 1 (unit)
29	770647003	X sensor set plate (unit)

PARTS LIST

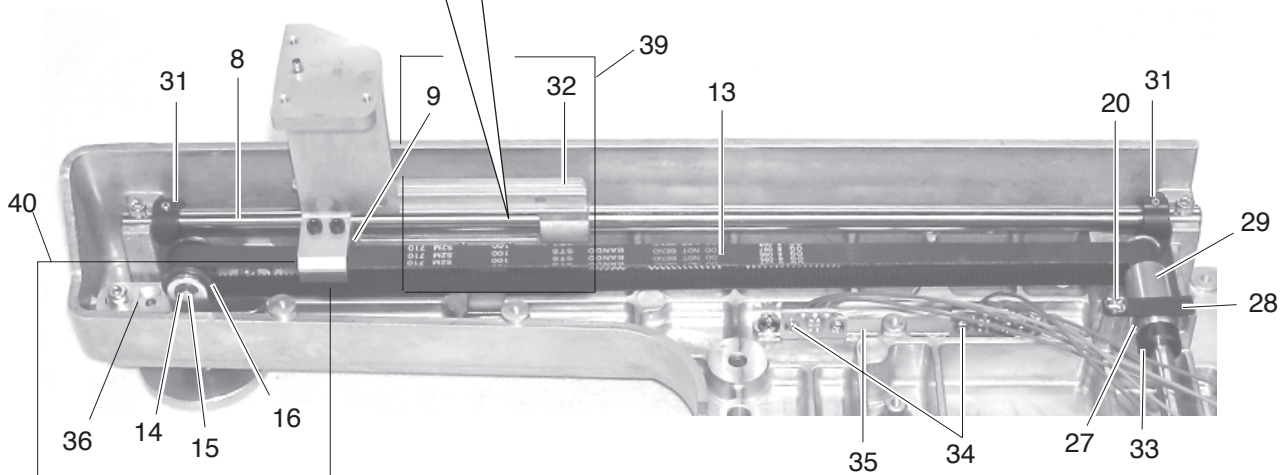
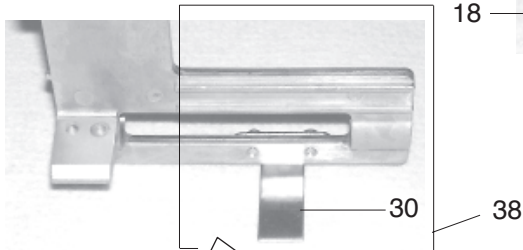
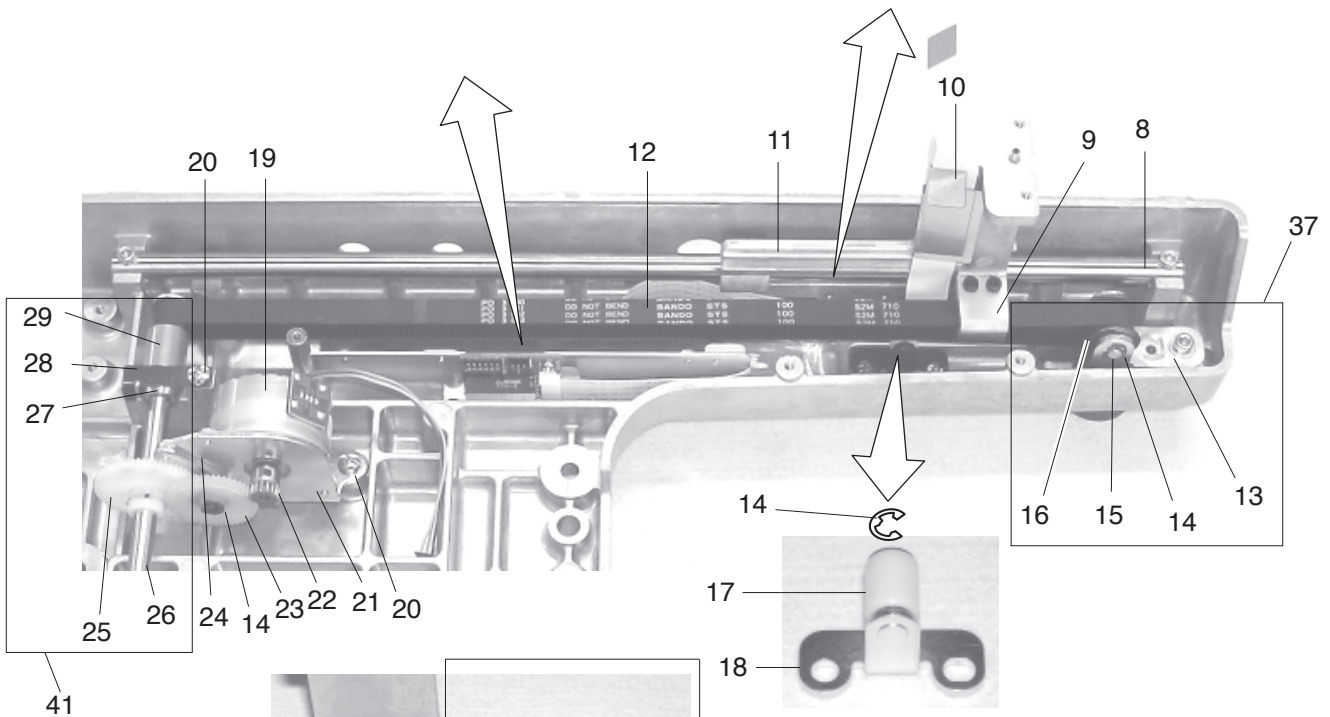
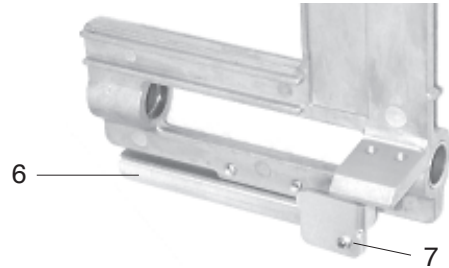
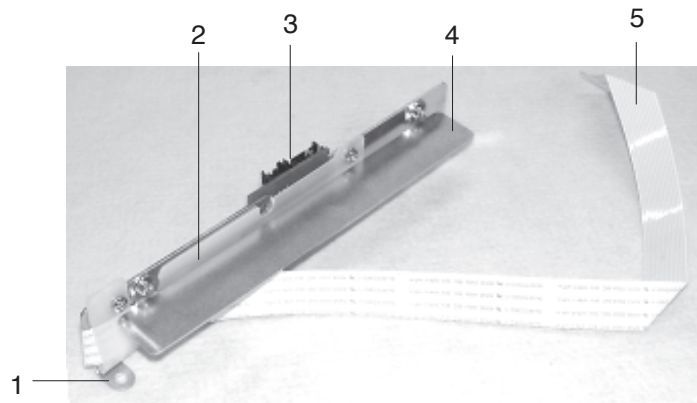

## PARTS LIST

KEY NO.	PARTS NO.	DESCRIPTION
1	770300001	Printed circuit board bracket 2
2	770384009	Cable guide 2
3	770503706	Printed circuit board E2 (unit)
4	770403005	Belt guide plate
5	770542007	Flexible cable (unit)
6	770301002	Flexible set plate
7	770183006	Cable guide 1
8	770291008	Y carriage shaft
9	770288002	Y belt foot
10	770302003	Cording foot
11	770274005	X carriage connecting block L
12	770290007	Y timing belt
13	770256001	Y tension pulley right plate
14	000002507	Snap ring E 4
15	770296003	Y tension pulley shaft
16	770528007	Tension pulley (unit)
17	770383008	Belt roller
18	770398006	Belt roller (unit)
19	770532004	Stepping motor
20	000101404	Setscrew 4x6
21	770286000	Y pulse motor bracket
22	770379001	Motor gear
23	770380005	X gear
24	850110106	X gear set plate
25	770284008	Y drive pulley
26	770281005	Y carriage gear shaft
27	770529008	Spherical metal (unit)
28	770287001	Metal supporter
29	770530002	Timing belt pulley (unit)
30	770292009	Y carriage sensor plate
31	770303004	Y rail stopper
32	770272003	X carriage connecting block R
33	770282006	Collar
34	770567008	Motor harness Y (unit)
35	770298005	Sensor set plate
36	770257002	Y tension pulley left plate
37	770652001	Y tension pulley right plate (unit)
38	770651000	X carriage connecting block L (unit)
39	770650000	X carriage connecting block R (unit)
40	770653002	Y tension pulley left plate (unit)
41	770654003	Y carriage gear shaft (unit)

# PARTS LIST

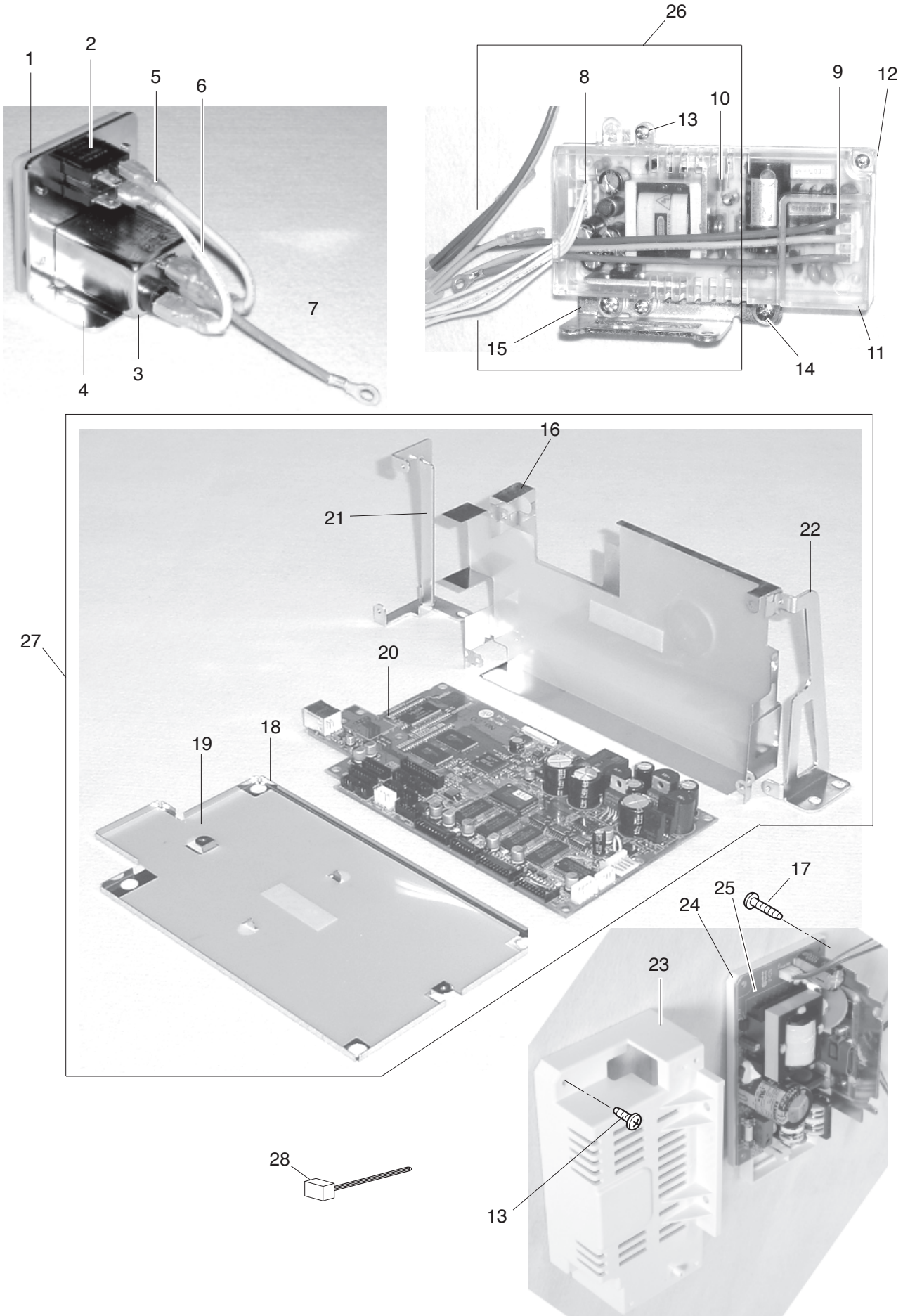

## PARTS LIST

KEY NO.	PARTS NO.	DESCRIPTION
1	770235200	Inlet lid
2	860545002	Main switch
3	770562014	Noise filter inlet
4	770333003	Inlet set plate
5	770544009	Inlet cord (unit)
6	770544102	Inlet cord (unit)
7	770555003	Grounding cord (unit)
8	770549004	Secondary power supply harness (unit)
9	770545000	Primary power supply harness (unit)
10	770538000	Switching power supply 30W (unit)
11	860062011	Switching power supply case
12	860063104	Switching power supply plate
13	000161309	Setscrew 3x12 (B)
14	000081016	Setscrew 4x8
15	770388003	Set plate A (30W)
16	770391009	Shielding case B (2)
17	000161206	Setscrew 3x10 (B)
18	770390008	Shielding case B (1)
19	770392000	Insulation sheet B (1)
20	770463106	Printed circuit board B (unit)
21	770337007	Printed circuit board left set plate
22	770336006	Printed circuit board right set plate
23	770386001	Auxiliary power supply case
24	770387002	Case lid
25	860519029	Switching power supply (unit)
26	770607001	Auxiliary power supply (unit)
27	770604008	Shielding case B (unit)
28	770585002	Short connector (unit)



# PARTS LIST

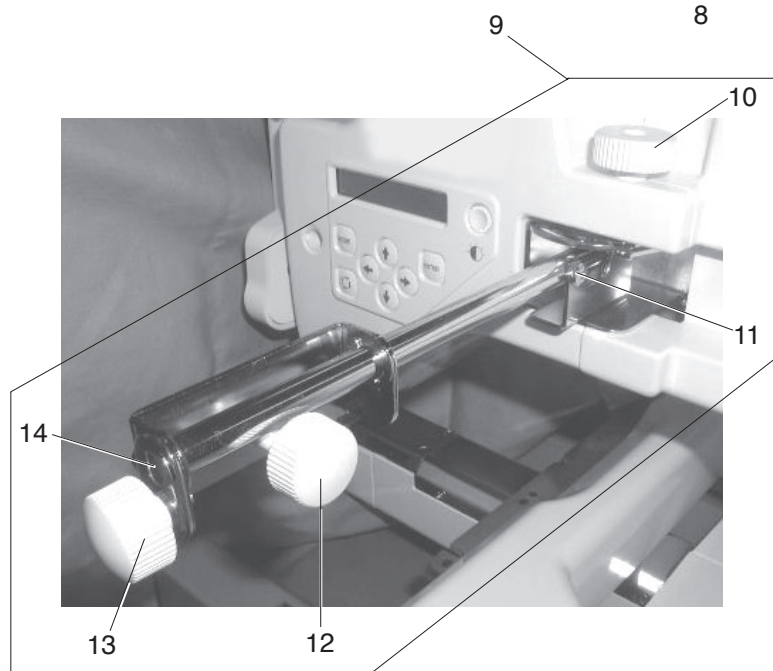
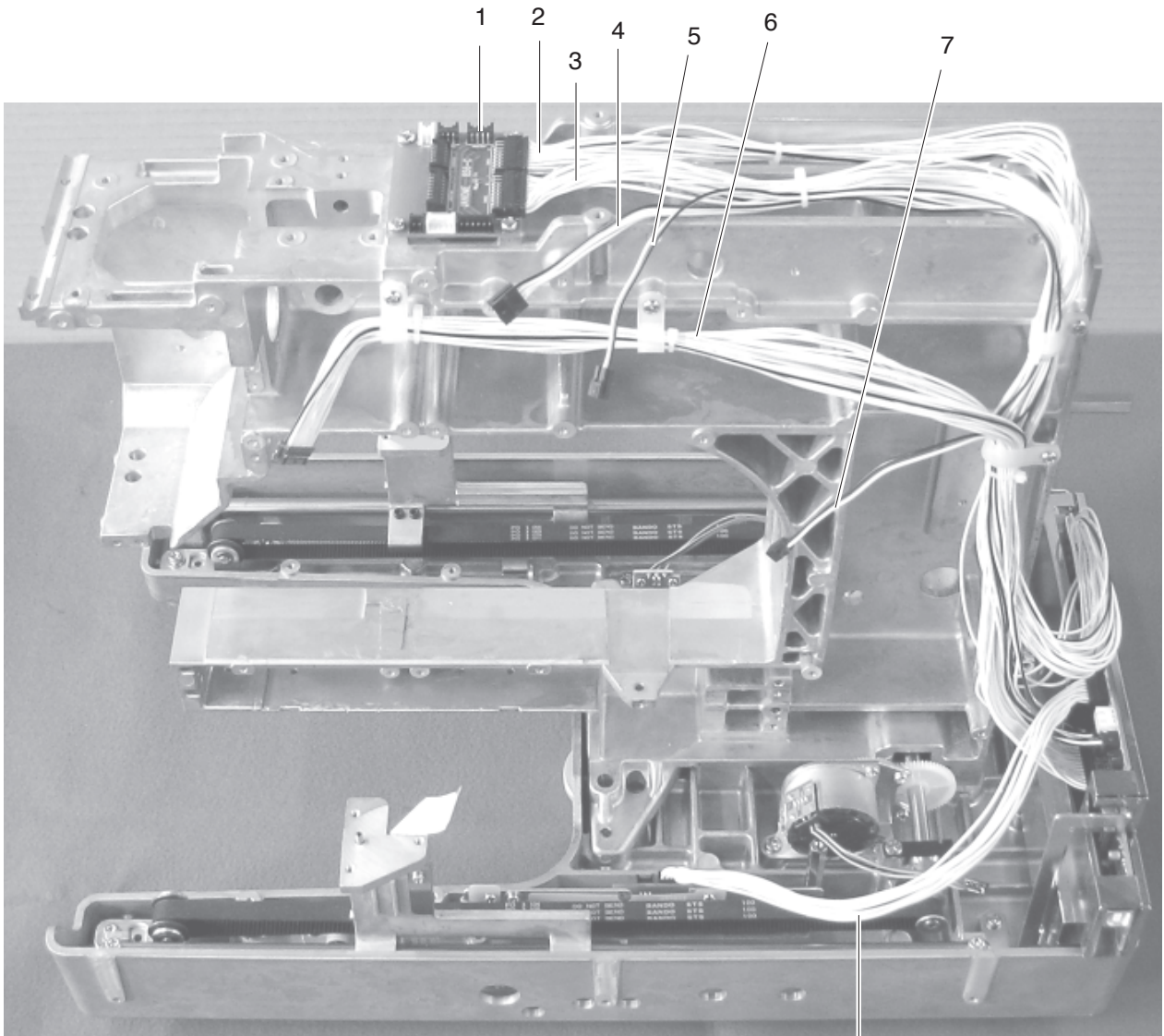

## PARTS LIST

---

KEY NO.	PARTS NO.	DESCRIPTION
1	770531003	Printed circuit board C (unit)
2	860530107	Harness (unit) (18P)
3	770540005	Harness (unit) (20P)
4	770552000	Harness (unit) (6P)
5	770546001	Harness (unit) (3P)
6	770554002	Harness (unit) (24P)
7	770553001	Harness (unit) (2P)
8	860565008	Harness (unit) (12P)
9	770621001	RCS arm (unit)
10	770308009	RCS knob
11	000103509	Setscrew 4x10
12	770413008	RCS knob (3)
13	770412007	RCS knob (2)
14	000115216	Setscrew TP 4x6

---

# PARTS LIST

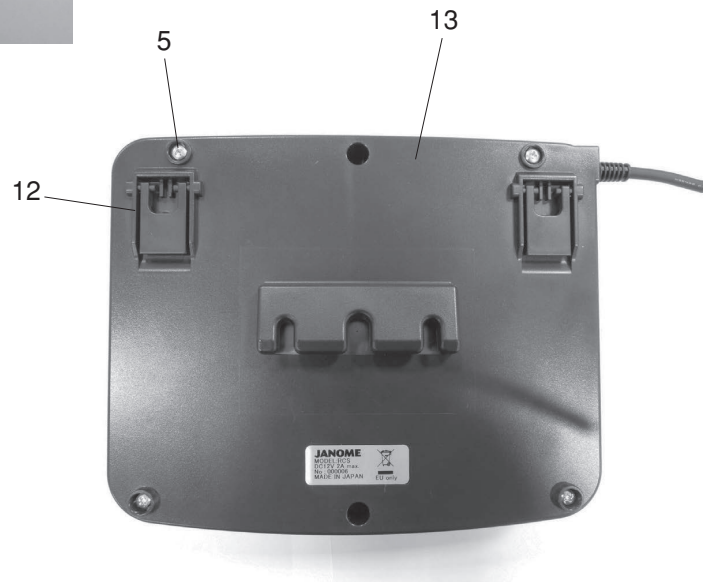
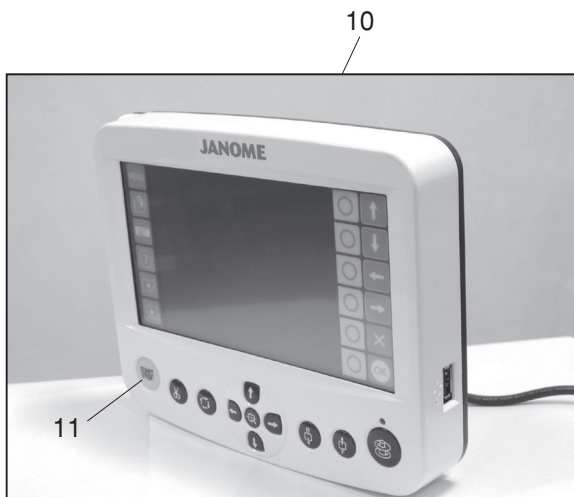
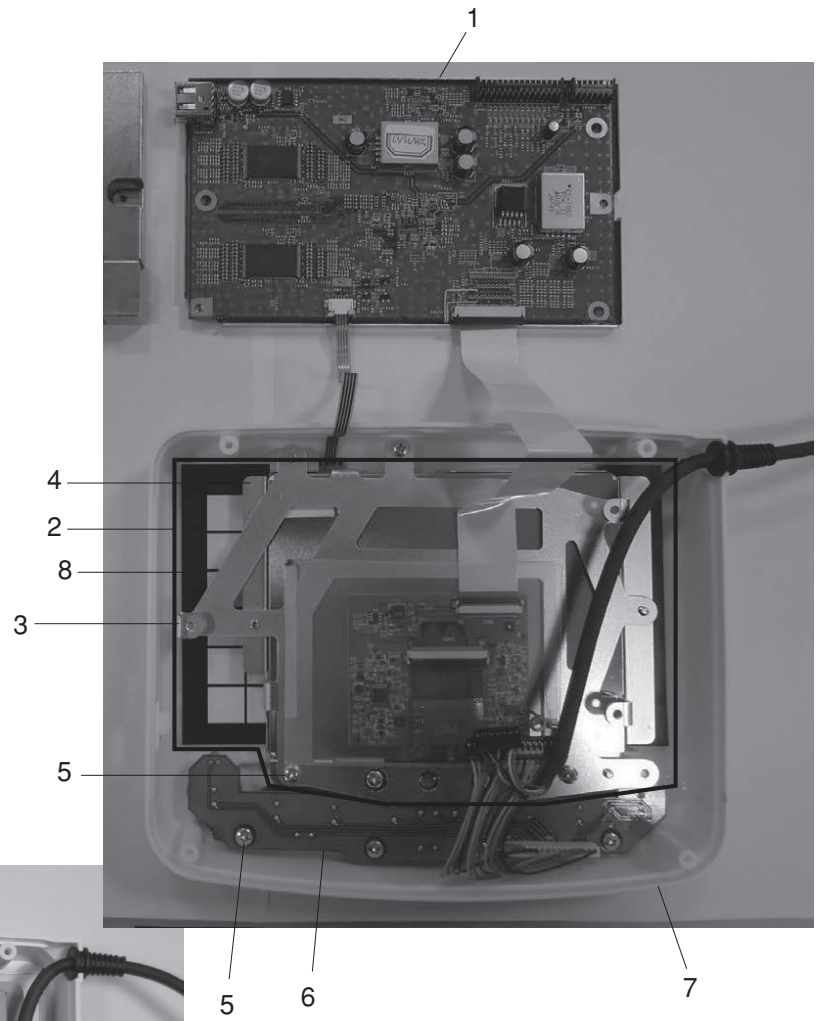



## PARTS LIST

---

KEY NO.	PARTS NO.	DESCRIPTION
1	770465201	Printed circuit board A (unit)
2	770664006	LCD (unit)
3	770970008	LCD set plate 1
4	770971009	LCD set plate 2
5	000161206	Setscrew 3x10 (B)
6	770520009	Printed circuit board F (unit)
7	770965A02	RCS cover
8	770584001	LCD (unit)
9	770665007	Shield case (unit)
10	770663005	RCS (unit)
11	770343109	Start/Stop button
12	770353205	RCS leg
13	770342212	RCS rear lid

---

# PARTS LIST

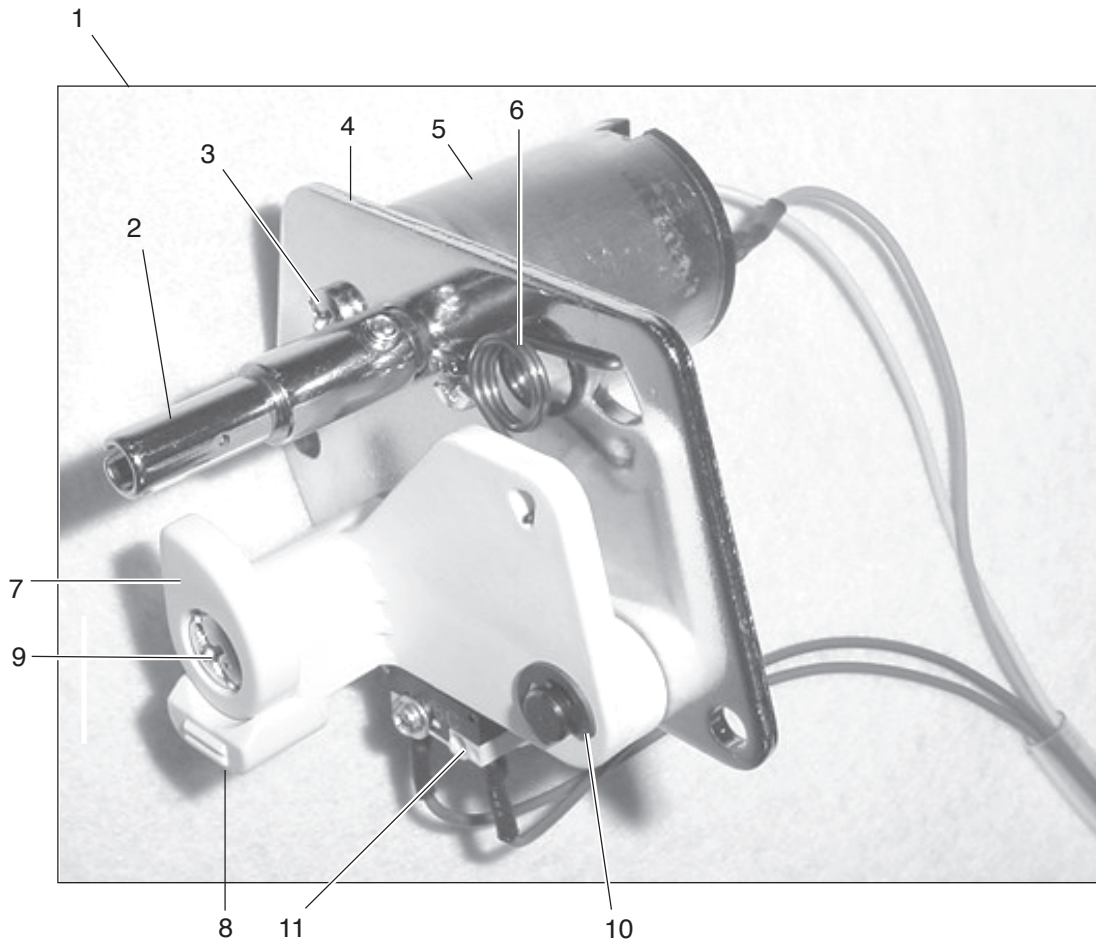

## PARTS LIST

---

KEY NO.	PARTS NO.	DESCRIPTION
1	770603100	Bobbin winder (unit)
2	767508001	Bobbin winder shaft (unit)
3	000101105	Setscrew 3x4
4	770330011	Bobbin winder set plate
5	846510107	Bobbin winder motor (unit)
6	846178109	Bobbin winder spring
7	846177108	Bobbin winder stopper
8	846176107	Bobbin winder lever
9	000104119	Setscrew 4x20
10	000002507	Snap ring E 4
11	846514101	Micro switch (unit)

---

# PARTS LIST

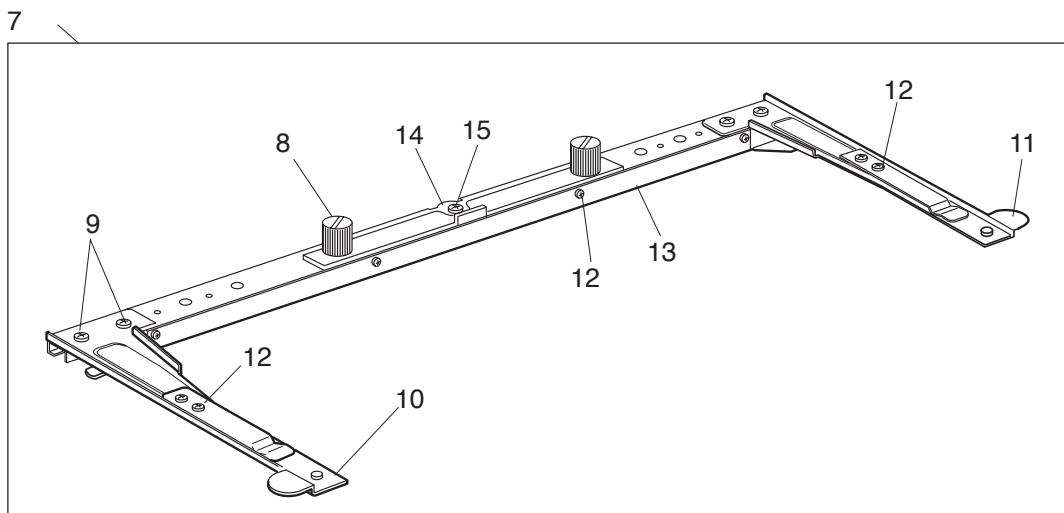
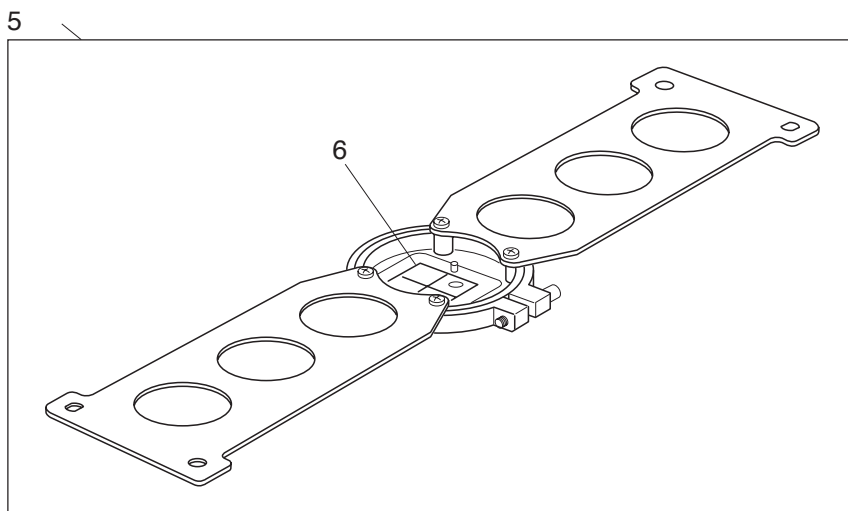
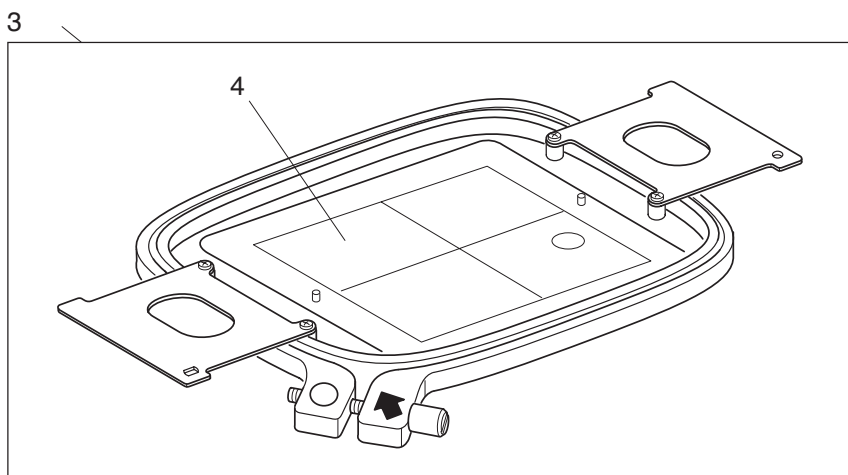
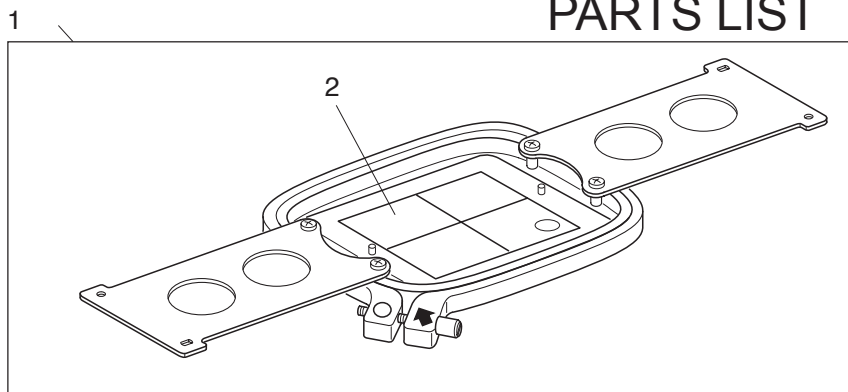

## PARTS LIST

---

KEY NO.	PARTS NO.	DESCRIPTION
1	770808004	Standard hoop M2 (unit)
2	770808200	Template sheet (standard)
3	770807003	Large hoop M1 (unit)
4	770807209	Template sheet (large)
5	770809005	Small hoop M3 (unit)
6	770809201	Template sheet (small)
7	770523002	Connecting arm fixing knob (unit)
8	770319003	Hoop knob (2)
9	000217909	Setscrew 4x8
10	770315009	Hoop supporting arm (L) (Unit)
11	770314008	Hoop supporting arm (R) (unit)
12	000103819	Setscrew 3x5
13	770440004	Support plate
14	770385000	Support roller
15	000101415	Setscrew 4x6

---

# PARTS LIST

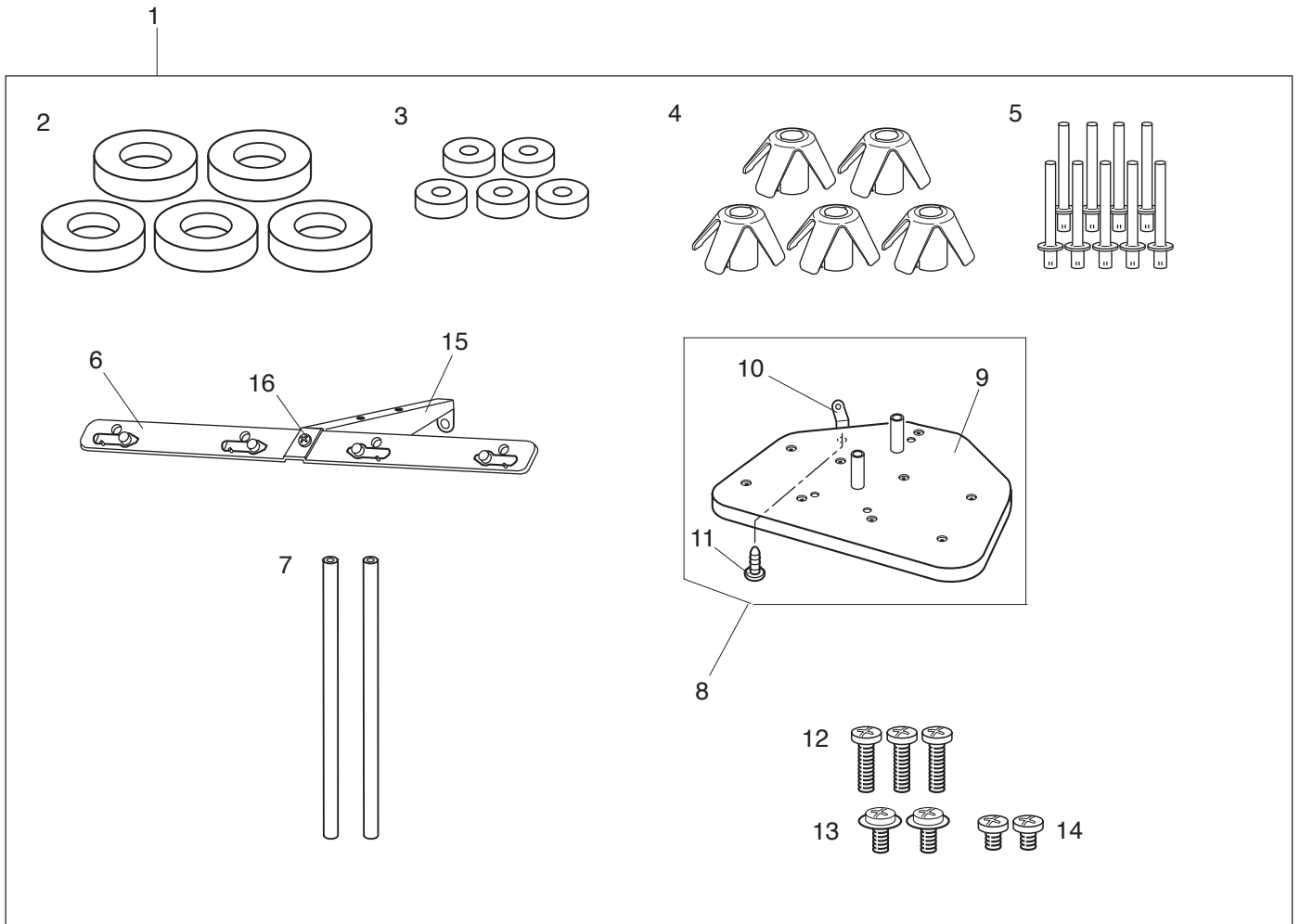

## PARTS LIST

---

KEY NO.	PARTS NO.	DESCRIPTION
1	770624004	Spool stand (unit)
2	770406019	Felt
3	770364014	Spool stand (felt)
4	770850001	Spool supporter
5	770421009	Spool pin
6	770623003	Thread guide (unit)
7	770259004	Support rod
8	770622002	Spool stand (unit)
9	770420008	Spool stand (2)
10	770360009	Bobbin thread guide
11	000261001	Setscrew 3x8
12	000106812	Setscrew 4x35
13	000115700	Setscrew TP
14	000081016	Setscrew 4x8
15	770359005	Thread guide arm
16	000078320	Setscrew 3x6

---

# PARTS LIST

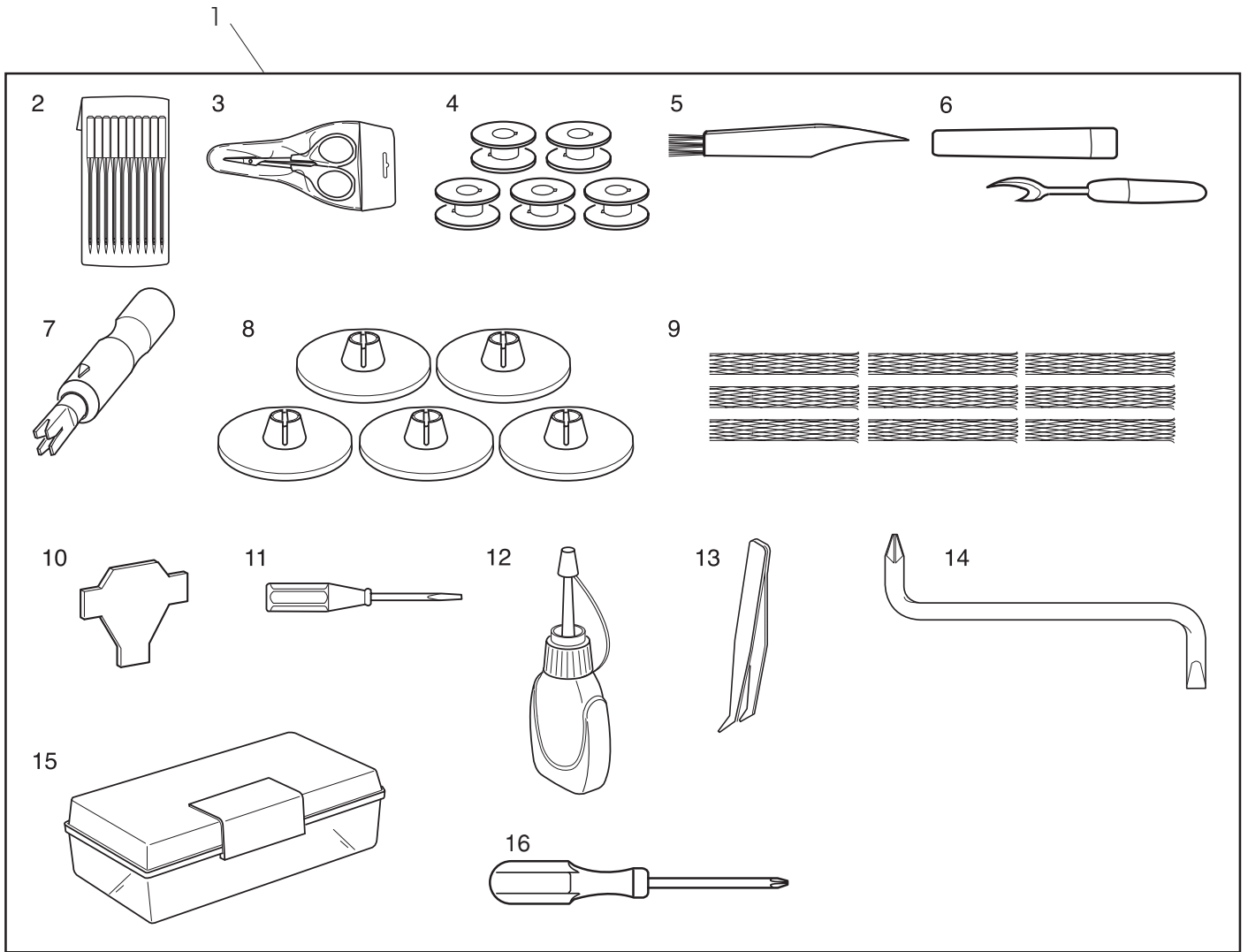

17 (flat 2-pin plug with grounding)

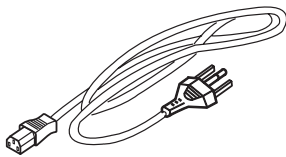

17 (flat 3-pin plug)

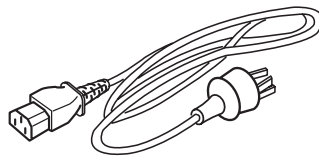

17 (round 2-pin plug)

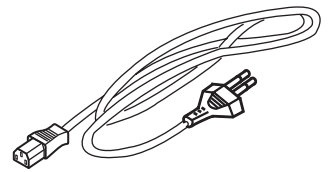

18

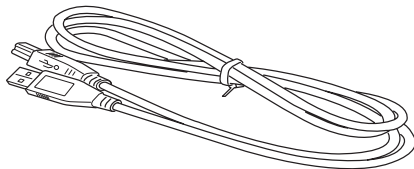

19

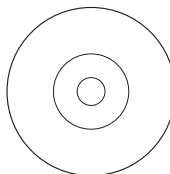

20

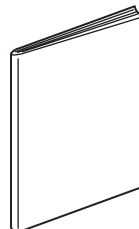



## PARTS LIST

KEY NO.	PARTS NO.	DESCRIPTION
1	770863007	Standard accessories (unit)
2	770811000	Needle
3	803813203	Scissors
4	770591001	Bobbin
5	802424004	Lint brush
6	647808009	Seam ripper
7	200254007	Needle threader
8	822020503	Spool holder (large)
9	624806202	Net
10	653802002	Screwdriver
11	792030005	Screwdriver (small)
12	770816108	Oil
13	888804008	Tweezers
14	770810009	Offset screwdriver
15	366401400	Standard accessory case
16	718410003	Screwdriver
17	980559200	Power supply cord (flat 2-pin plug with grounding)
	980542015	Power supply cord (flat 3-pin plug)
	980543005	Power supply cord (round 2-pin plug)
18	850403006	USB cable
19	770861005	Instruction CD
20	770865009	Instruction book (English)
	770865205	Instruction book (Spanish)
	770865308	Instruction book (French)