

JAYANG
大洋衣车



自动磨刀裁剪机

AUTO-SHARPENING CUTTING MACHINE

使用手册零件目录
User Guide & parts list

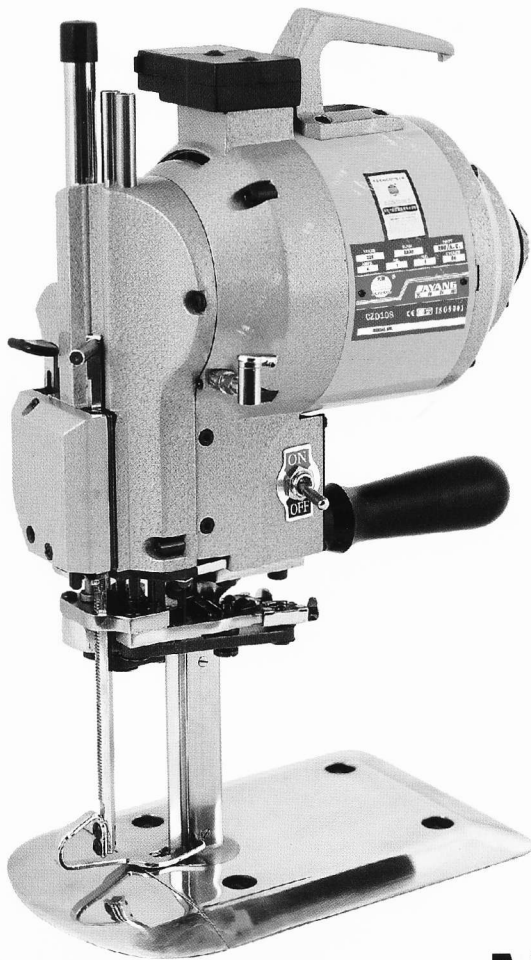

*5" Straight
Knife*

MODEL:CZD108

REAT 大洋
OCEAN



开机前 START ON

1. 向油杯“T”注油，确保油进。 2. 按手轮“C”回转几次，以便油顺利润滑。 3. 磨刀器必须停留在起始自锁位置。
1. Fill oil cup A, be sure oil goes into smooth, remove obstruction.
2. Push in E and turn thr machine by hand for a few revolutions to make sure the oil is spread over contact surfaces.
3. The sharpener must be always up in locked position when starting.

注意 BE CAREFUL

- a. 天冷时，请将机器放置在暖和的地方。
 - b. 在机器连续运转之前，应将机器通电开闭几次，可使油预热。
 - c. 不要用过多的油，不要用缝纫机油，请使用 30 号机油。
 - d. 万一你的机器处于双重运速状态，请注意以下两点：
 - (1) 开机时，将开关调至最高速，当全速旋转后调至低速。
 - (2) 以低速连续运转，不得超过 30 分钟。
- a. Keep the machine in warm place in cold weather.
 - b. Repeat short on & off before permitting the machine to run continuously for preventing excessive friction between contact surfaces.
 - c. Do not use too much oil. Do not use sewing machine oil Use a least good grade of No.30 motor oil.
 - b. In case your cutter is of DUAL SPEED TYPE, please take care of the following two points:
 - (1) Be sure io select the switch to the upper high speed(HI) in starting, and then, when full revolution has been attained, to the lower speed(LO). The switch is put off by selecting the intermediate OFF.
 - (2) The continuous operation at low speed (LO) should be no more than 30 minutes. **DO NOT OPERATE FOR MORE THAN 30 MONUTES.**

供油 LUBRICATION

每天 2 次 EVERY 2HOURS DAILY	每周一次 ONCE A WEEK	每月一次 ONCE A MONTH
向油杯“T”注油(连杆轴承无须加油) Fill oil tank A (no need to oil at connecting rod bearing)	请适当给以下部位注油 One drop oil to: 1. 导向管 N. 2. 手轮 C. 3. 右方轴 W. 4. 后部砂带导轮 V. 1. Tubes-N. 2. Turn Knob-C. 3. Pulley Shaft-W. 4. Belt Pulleys-V.	重新移动活塞 D，并插入输油管。 Remove D plug and insert grease tube. Give a peasize amount to the opening.

磨刀 SHAPENER OPERATION

1. 将机器离开裁料 2. 将压脚杆下降最下面 3. 用力将杠杆 G 慢慢按下。
1. Put the machine away from pioes of material.
2. Drop pressure foot by lever located next to operating handle.
3. press lever G downward firm but not too puick.

注意 BE CAREFUL

- a. 机器未装刀片时切勿磨刀。 b. 机器正在裁剪时，切勿磨刀。 c. 磨刀器正在磨刀时，切勿关闭电机。 c. 如果杠杆 G 中途堵塞，将杠杆 H 提起并重新启动。
- a. Do not operate sharpener without knife in machine.
- b. Do not operate sharpener with cutting material laid in machine.
- c. Do not shut off motor while sharpener is in motion.
- d. If lever G is locked in halfway by too quick operation, lift lever H to unlock and start again.

注意 CARE

1. 每周两次用风箱把电机和磨刀器上的线头吹掉。
2. 每星期一次取下凸轮罩盖 K，将往复螺轴上的线头清理干净，
3. 每天使用清洁槽清洗衬片组件。
4. 将底盘上的线毛清理掉，请勿向底盘导轮注油，若导轮滚动不灵，请拆下清洗。
1. Blow lint of motor and sharpener by blower or something alike twice a week.
2. Lint around screw mechanism of sharpener inside cover k must be cleaned once a week.
3. Clean the knife slide by slot cleaner once a day.
4. Remove lint from rollers in base plate. To prevent undue accumulation of lint, do not oil plate rollers. If rollers stick, remove from plate and wash in cleaning solvent.

FRONT COVER MECHANISM

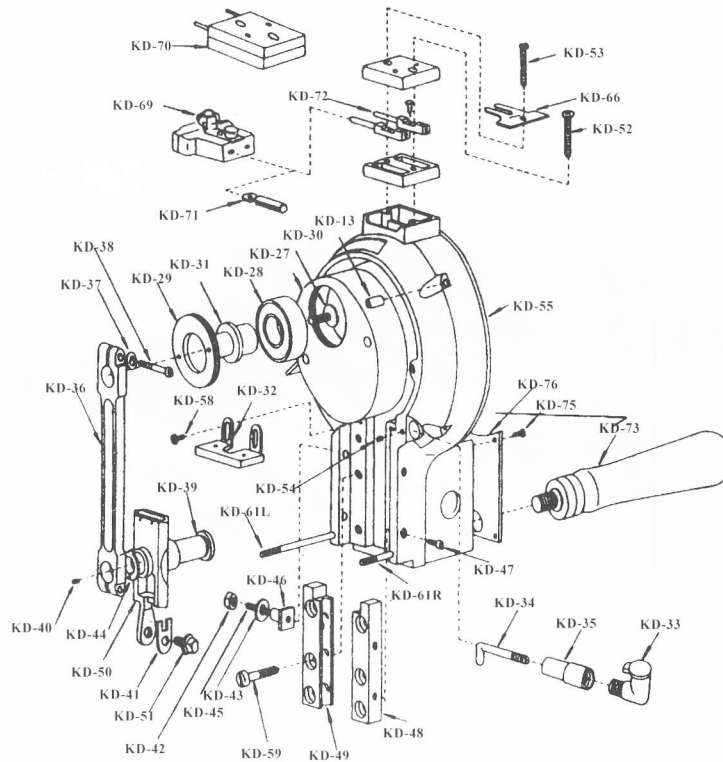

零件号 Part NO.	Name of parts	零件名称	零件号 Part NO.	Name of parts	零件名称
KD-13	Front to Rear Bearing Nut	螺母	KD-47	Guide Lock Screw	滑枕螺钉
KD-27	Crank	曲柄	KD-48	R.H.Guide	右侧滑枕
KD-28	Crank Ball Bearing	曲柄轴承	KD-49	L.H.Guide	左侧滑枕
KD-29	Crank Ball Bearing Lock Nut	轴承盖	KD-50	Cross Head	滑枕
KD-30	Screw for Brag Shaft	轴承轴螺钉	KD-51	Knife Lock Bolt	方头螺钉
KD-31	Shaft for Ball Bearing	轴承轴	KD-52	Terminal Block Screw	插座连接板螺钉
KD-32	Oil Pad Holder	导油管座	KD-53	Ground Clip Screw	螺钉
KD-33	Oil Cup	油杯	KD-54	Set Screw	紧定螺钉
KD-34	Oil Tube for Wrist Pin(Copper)	滑枕轴导油管	KD-55	Front Bearing Housing	前端盖
KD-35	Oil Tube for Wrist Pin	滑枕轴导油套	KD-58	Oil Pad Holder Screw	导油管座螺钉
KD-36	Connecting Rod	连杆	KD-59	Guide Hold Down Screw	螺钉
KD-37	Shakeproof Washer	垫圈	KD-61L	Stud Lower L.H.Mountaing(L)	双头螺栓
KD-38	Connecting Rod Clamp Screw	连杆夹螺钉	KD-61R	Stud Lower L.H.Mountaing(R)	短双头螺栓
KD-39	Wrist Pin	滑枕轴	KD-66	Ground Clip	插座连接板
KD-40	Wrist Pin Plug	油堵	KD-69	Attachment Plug (Complete)	插头组合
KD-41	Knife Lock Washer	方头螺钉垫	KD-70	Tetminal Block (Complete)	插头组合
KD-42	Nuts for Guide Screw	螺母	KD-71	Terminal Sleeve	连接销
KD-43	Guide Washer	垫圈	KD-72	Terminal Contact With Pin	终端连接销
KD-44	Connecting Rod Washer	垫片	KD-73	Operating Handle	手柄
KD-45	Guide Adjusting Screw	螺母	KD-75	Switch Cover Screw	后盖板螺钉
KD-46	Guide Adjusting Nut	方头调节螺母	KD-76	Switch Cover	后盖板

SHAPPENER HOUSING MECHANISM

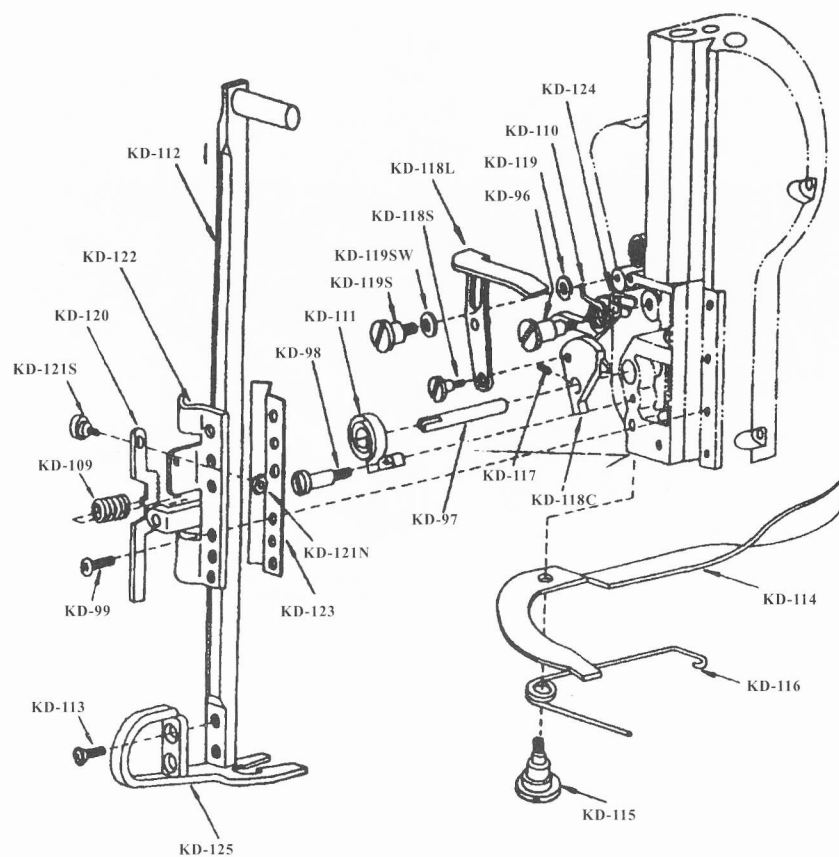

零件号 Part NO.	Name of parts	零件名称	零件号 Part NO.	Name of parts	零件名称
KD-96	Screw for Latch	变向柄螺钉	KD-118S	Screw for Cam	变向凸轮螺钉
KD-97	Shaft for Cam	凸轮轴	KD-119S	Lock Screw for Release Lever	螺钉
KD-98	Cam Shaft Spring Screw	弹簧螺钉	KD-119SW	Spring Washer	弹簧垫圈
KD-99	Pres Foot Lock Bracket Screw	压脚架螺钉	KD-120	Washer	垫圈
KD-109	Spring for Pressure Foot Lock	压紧弹簧	KD-121S	Loch(only)Pressure Foot	齿板
KD-110	Spring for Latch	变向柄弹簧	KD-121N	Screw for Pres Ft Lock	齿板轴螺钉
KD-111	Cam Spring	凸轮弹簧	KD-122	Nut for Pres Ft Lock	齿板螺母
KD-112	Pressure Foot Rod	压脚杆	KD123	Pressure Foot Lock Bracket	压脚导板
KD-113	Screw for Pressure Foot Shoew	螺钉	KD-124	Latch for Cam	变向柄
KD-114	Pressure Foot Lever	压脚手柄	KD-125	Pressure Foot Shoe	压脚
KD-115	Pressure Foot Lever Screw	压脚手柄螺钉			
KD-116	Spring for Pressure Foot Lever	压却手柄弹簧			
KD-117	Set Screw for Cam	凸轮螺钉			
KD-118C	Cam	变向凸轮			
KD-118L	Release Lever	磨刀手柄组合			

LOWER GEAR BRACKET MECHANISM

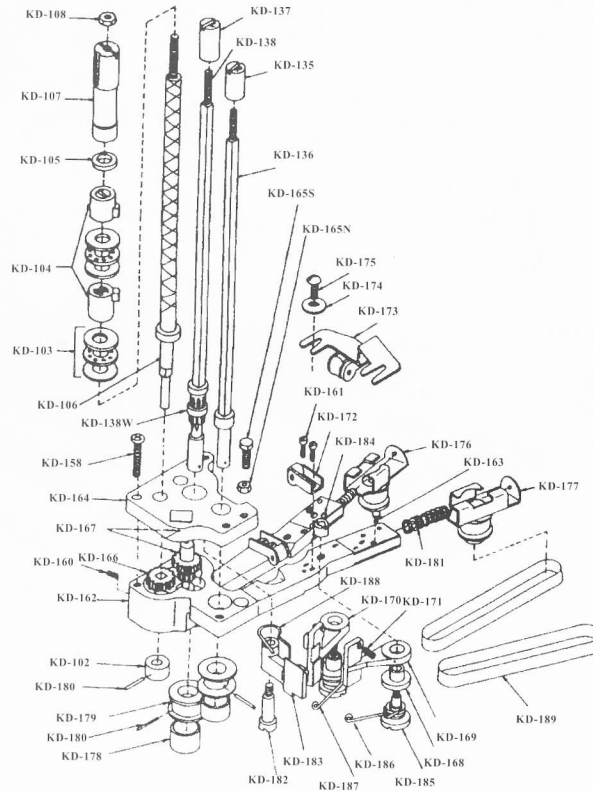

零件号 Part NO.	Name of parts	零件名称	零件号 Part NO.	Name of parts	零件名称
KD-102	Collar for Lower Screw Shaft		KD-168	Bushing for Shoe	夹板座套
KD-103	Thrust Ball Bearing	推力轴承组合	KD-169	R.H.Shoe	右夹板
KD-104	Nut for Screw Shaft L.H.&R.H	右左施螺母	KD-170	L.H.Shoe	左夹板
KD-105	Washer for Screw Shaft L.H	左螺母垫	KD-171	Set Screw for Sharpener Shoe	夹板螺钉
KD-106	Screw Shaft With Extension	往复螺轴	KD-172	Stabilizer	平衡架组合
KD-107	Spacer Tube	调节套筒	KD-173	Guide Back of Standard	后导轮架组合
KD-108	Stop Nut for Screw Shaft	调节螺母	KD-174	Washer for Guide Back	后导轮架垫圈
KD-135	Right Hand Follower Nut	右方轴导向柱	KD-175	Screw for Guide Back	后导轮架螺钉
KD-136	R.H.Square Shaft	左方轴	KD-176	L.H.Slide With Pulley	左涨紧轮导架
KD-137	Left Hand follower Nut	左方轴导向柱	KD-177	R.H. Slide With Pulley	右涨紧轮导架
KD-138	L.H.Square Shaft	左方轴	KD-178	Neoprene Band	橡胶圈
KD-138W	L.H.Square Shaft Washer	左方轴垫圈	KD-179	Front Pulley for Belts	砂带前导轮
KD-158	Screw for Gear Cover	齿轮盖螺钉	KD-180	Roll Pin for Pulley	滚针
KD-160	Grease Plug	油堵	KD-181	Spring for Pulley Slide	涨紧轮弹簧
KD-161	Screw for Stabilizer	平衡架组合螺钉	KD-182	Screw for Clamping Arm	限位调节板螺钉
KD-162	Lower Gear Bracket	砂带架	KD-183	Clamping Arm for Shoe	限位调节板
KD-163	Screw for Slide Pulley		KD-184	Nut for Sharpener Shoe Screw	螺母
KD-164	Lower Gear Bracket Gear Cover	砂带架齿轮盖	KD-185	Screw for Sharpener Shoe	夹板螺钉
KD-165N	Adjusting Nut	调节螺母	KD-186	R.H.Sharpener Shoe Spring	右夹板弹簧
KD-165S	Adjusting Screw	调节螺钉	KD-187	L.H. Sharpener Shoe Spring	左夹板弹簧
KD-166	Gear on Screw Shaft	齿轮轴套	KD-188	Spring for Arm	限位调节弹簧
KD-167	Intermediate Gear	双链齿轮	KD-189	Abrasive Belts	砂带

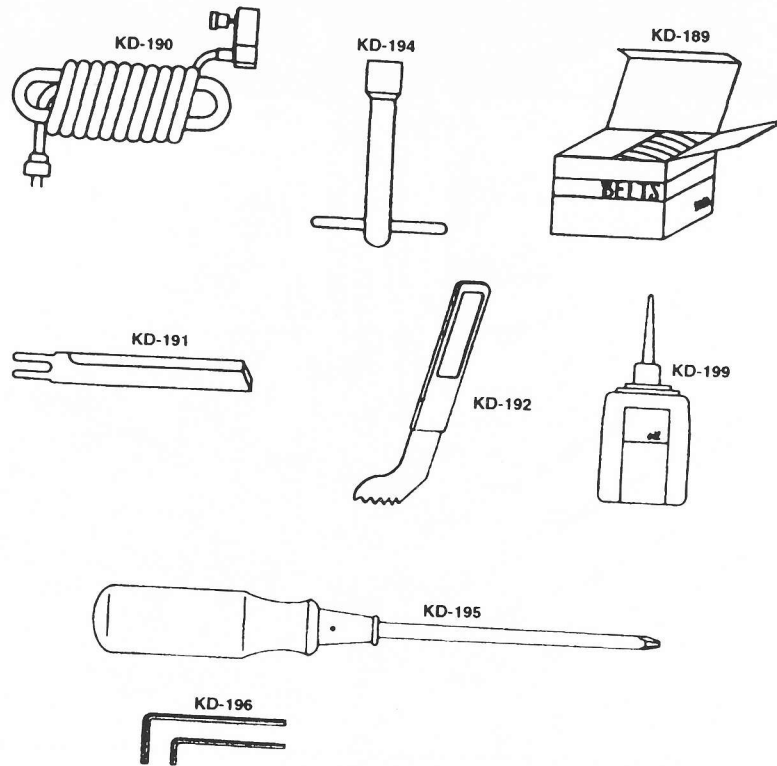

零件号 Part NO.	Name of parts	零件名称	零件号 Part NO.	Name of parts	零件名称
KD-189	Abrasive Belts	砂带	KD-194	Knife Bolt Wrench	切刀板手闷
KD-190	Electric Corde Complete		KD-195	Screw Driver	传动螺丝刀
KD-191	Knife	刀片	KD-196	Wrench For Shoe Set Screw	
KD-192	Siot Cleaner	清洁槽	KD-199	Oiler	润滑油

SHARPENER HOUSING MECHANISM

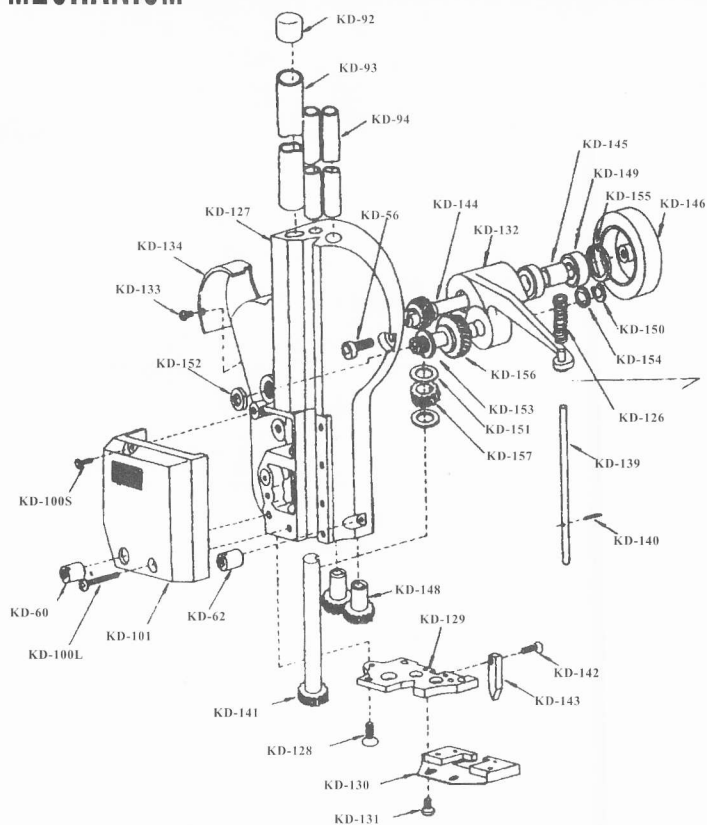

零件号 Part NO.	Name of parts	零件名称	零件号 Part NO.	Name of parts	零件名称
KD-56	Sharpener Hold Down Screw	螺钉	KD-139	Push Rod	止动杆
KD-60	Lower L.H.Sharpener	螺母	KD-140	Roll Pin for Push Rod	止动杆滚动销
	Hold down Nut		KD-141	Driver Shaft With Gear	长轴齿轮
KD-62	Stud,Guide Rod Brachet	螺母	KD-142	Screw for Spreader Pin	分离块螺钉
KD-92	Cap for Tube	导向管帽	KD-143	Spreader Pin	分离块
KD-94	Driving Shaft	传动轴	KD-144	Gear & Shaft	齿轮轴
KD-93	Right and Left Hand Follower	方轴导向管	KD-145	Bearing for Gear	齿轮轴承
KD-100S	Screw for Cover(S)	凸轮罩盖螺钉	KD-146	Rubber Driver & Driver Pulley	传动轮
	Screw for Cover(L)		KD-148	Spur Gear	方孔齿轮
KD-100L	Cover Over Can	凸轮罩盖	KD-149	Ball Bearing for Crank	轴承
KD-101	Spring for ell Crank	曲拐弹簧	KD-150	Retaining Ring	挡圈
KD-126	Sharpener Housing	磨削器外罩	KD-151	Thrust Washer for Spiral Gear	垫圈
KD-127	Bottom Plate Screw	外罩底盘螺钉	KD-152	Loch Nut for Crank Shaft	齿轮轴螺母
KD-128	Bottom Plate	外罩底盘	KD-153	Shaft for Crank	传动斜齿轮轴
KD-130	Oil Pad & Holder	油盘组合	KD-154	Washer for Crank Shaft	齿轮轴垫圈
KD-131	Screw for Oil Pad	油盘螺钉	KD-155	Lock Nut for Ball Bearing	轴承螺母
KD-132	Bell Crank With Pin & Bushing	曲拐	KD-156	Ldler Gear With Bushing	传动斜齿轮
KD-133	Screw for Cover	螺钉	KD-157	L.H.Spiral Gear With Key	键槽斜齿轮
KD-134	Cover for Driver	传动轮盖			

STANDARD & BASE PLATES

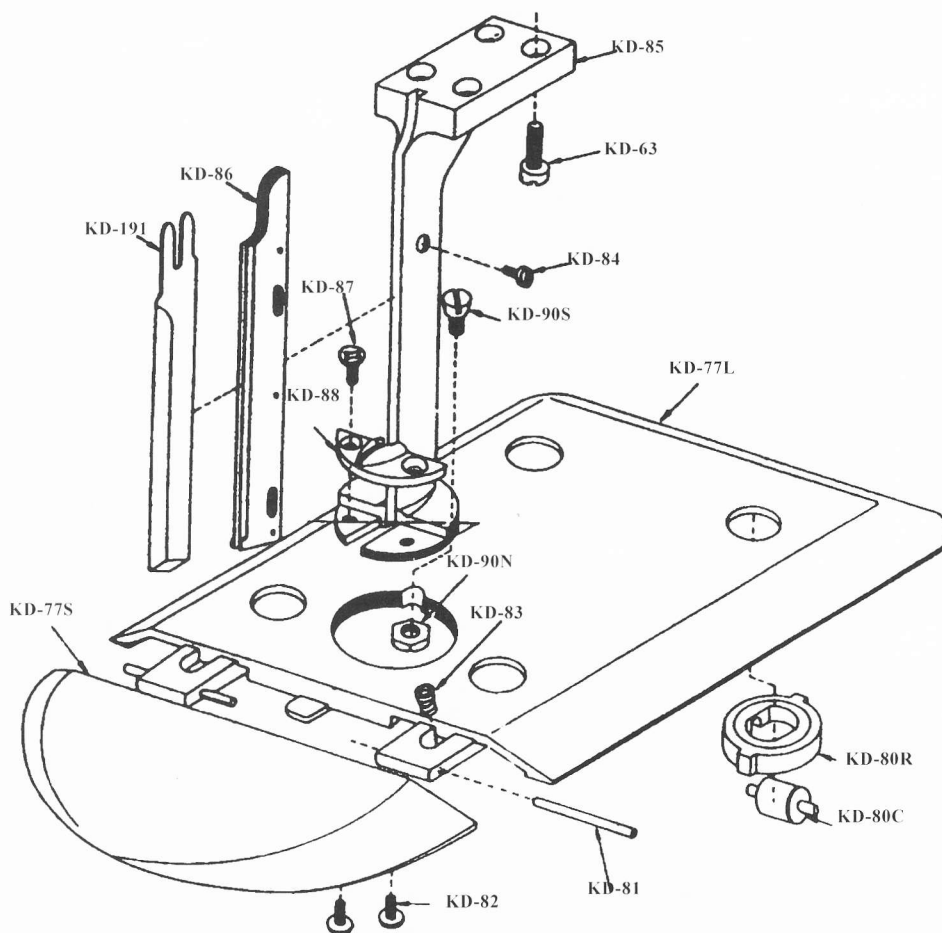

零件号 Part NO.	Name of parts	零件名称	零件号 Part NO.	Name of parts	零件名称
KD-63	Standard-to-Bearing Screw	螺钉	KD-88	Throat Plate	左刀库舌
KD-77S	Plate Wing	盘翼	KD-90S	Plate Screw	底盘销
KD-77L	Plate	底盘	KD-90N	Plate Nut	六角螺母
KD-80C	Roller	滚子	KD-191	Knife	刀片
KD-80R	Rubber	滚子架橡皮圈			
KD-81	Hinge Pin Short	芯轴			
KD-82	Hinge Pin Clamp Screw	底盘螺钉			
KD-83	Plate Wing Tension Spring	盘翼夹线弹簧			
KD-84	Knife Slide Screw	衬片螺钉			
KD-85	Standard	刀库			
KD-86	Knife Slide	衬片组合			
KD-87	Screw for Throat Plate	螺钉			

MOTOR & HOUSING MECHANISM

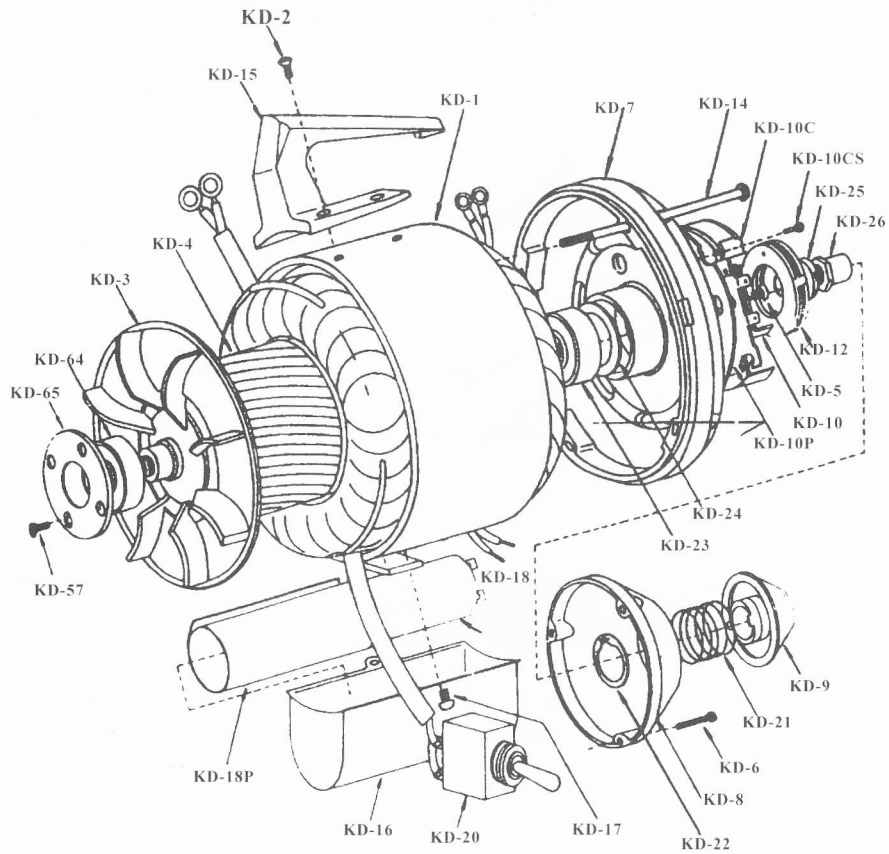

零件号 Part NO.	Name of parts	零件名称	零件号 Part NO.	Name of parts	零件名称
KD-1	Capacitor-Stator	定子	KD-15	Carring Handle	提手
KD-2	Carrying Handle Screws	提手螺钉	KD-16	Capacitor Cover	电容器盖
KD-3	Rotor Fan	风扇	KD-17	Screw for Capacitor Cover	电容器螺钉
KD-4	Rotor With Shaft	转子	KD-18	Capacitor	电容器
KD-5	Cut-Out Switch to Bearing Screw		KD-18P	Paper	电容器垫
KD-6	Dust Cap Screw	防尘盖螺钉	KD-20	Switch	扭子开关
KD-7	Rear Bearing Housing	后端盖	KD-21	Clutch Spring	离合器弹簧
KD-8	Dust Cap	防尘盖	KD-22	Retaining Ring	轴用弹性挡圈
KD-9	Turning Knob	手轮	KD-23	Rear Ball Bearing	轴承
KD-10	Cut-Out Switch	离心器	KD-24	Rear Ball Bearing Spring Washer	波形弹簧片
KD-10P	Insulated Plate	绝缘板	KD-25	Clutch Nut	离合器螺母
KD-10C	Insulated Cover	绝缘盖	KD-26	Shaft Lock Nut	锁紧螺母
KD-10CS	Set Screw for Insulated Cover	绝缘盖紧定螺钉	KD-57	Front Ball Bearing Retainer Screw	螺钉
KD-12	Automatic Cut-Out	离心开关	KD-64	Front Ball Bearing	前轴承
KD-14	Front to Rear Bearing Screw	后端盖长螺钉	KD-65	Front Ball Bearing Retainer	前轴承盖