

# **ROMITEX GA204-370**

**instruction manual**

**and**

**parts list**

## Contents

I.	Brief Introduction.....	1
II.	Main Characteristic.....	1
III.	Main Technical Specifications.....	1
IV.	Use and Maintenance.....	1
V.	Plan of Complete Machine.....	2
VI.	Attachment.....	2
VII.	Samples of Part.....	2
	(1)Body Unit.....	3
	(2)Armshaft and thread raising.....	5
	(3)Needle Bar and Pendulum Presser.....	7
	(4)Presser.....	9
	(5)Trapping thread and passing thread.....	11
	(6)Bobbin case and Bottom axle.....	13
	(7)Feeding.....	15
	(8)Lifting tooth.....	17
	(9)Presser Lifter.....	18
	(10) Bobbin Winder.....	20
	(11) Components of Frame.....	22--23
VIII.	Operation Method and Adjustment	
	1. Installation of Needle.....	24
	2. Take out Bobbin.....	24
	3. Coiling the Bobbin.....	24
	4. Threading the Pendulum Bobbin.....	24
	5. Threading the Facial Suture.....	25
	6. Regulation of Suture's Tension.....	26
	7. Regulation of Presser's Pressure.....	26
	8. Regulation of Stitch.....	26
	9. Regulation of Height of Needle Bar.....	26
	10.Adjustment of Height of Feeding tooth.....	26

## I. Brief Introduction

(GA-204 Large Sewing Machine for Thick Material) adopts single needle and pendulum bobbin, composite feeding, cam cross thread and presser alternating lift structure. It is the large sewing machine for the extra thick material with good combination property. It applies to sew the extra thick material for shoemaking, sofa, leather case and leather.

## II. Main Characteristic

It adopts the structure that the composite feeding, needle bar and press rod swing at the same time. The characteristic is: high precision of machine, high quality of sewing, it could ensure the up layer and down layer unshift in any length of stitch within the rated range when sewing the slippery material, sticky material and extra long products, so the products are neat and the line trace is beautiful. It also adopts cam to cross thread, especially when make the high-low sewing and climbing sewing, so the feeding is easy, the space of stitches is steady, the sewed layer is close, line trace is smooth and well proportioned. The complete machine has good property and complete oil-supply system, so it could increase the abrasion resistant extent of each part, reduce the noise, and prolong the service life of machine, It is the best machine for sewing extra thick products.

## III. Main Technical Specifications

Speed of sewing	800R/Min
Length of stitch	12mm
Lifting height of presser	20mm
Model of needle	GV2 Model No. 110-280
When avale the presser the press the material:	
Thickness of material	≤16mm
Model of suture	Synthetic fiber wire 8/3, core wire 8/3, Braided thread 0.8
Ideotype of head	700×300×500
Power of electric motor	0.55KW (Special use for sewing machine)

## IV. Use and Maintenance

1. Before use the new or long term stored machine, you must clean the dust and antirust grease on the surface, pour a few drop of oil into the running part or sliding part of sewing machine and make it running a few minutes.
2. When the machine turns, the turn direction of upper wheel should be anticlockwise (watch from the outside of the upper wheel).
3. The model of needle and the thickness of suture should be in direct proportion with the thick or thin, hard or soft of material.
4. Clean the dust and lubricate all the part at least twice of each work shift.
5. Within the first month of use the machine, the speed of sewing could not over 600R/Min.

## V. Plan of Complete Machine

I. Body Unit

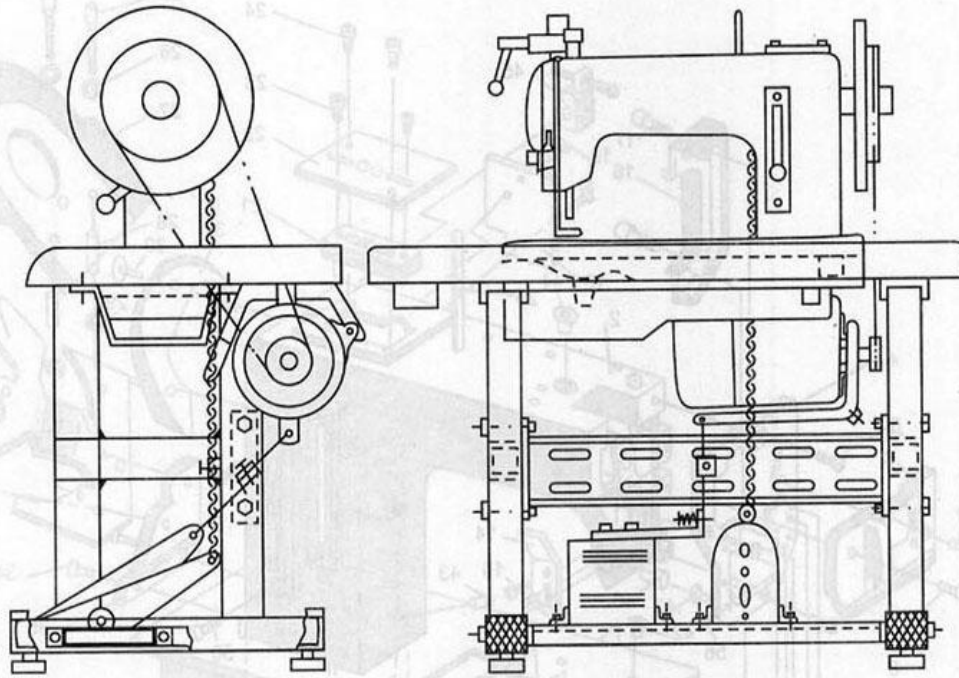

## VI. Attachment

1	Bobbin winoler	1	10	Big knife	1
2	Bracket	1 set	11	Small knife	2
3	Hinge	2 sets	12	Oiler	1
4	Rubber cushion	4	13	Needle	1 bag
5	Chain	1 set	14	Bobbin	5 bags
6	Foot-plate	1	15	Socket head cap screw spanner	1 set
7	“ “ Seat	2	16	Belt hood C.D	A pair of
8	“ “ Bolt	4			
9	Oil catcher	1			

## VII. Samples of part

# 1. Body Unit

V. Plan of Complete Machine

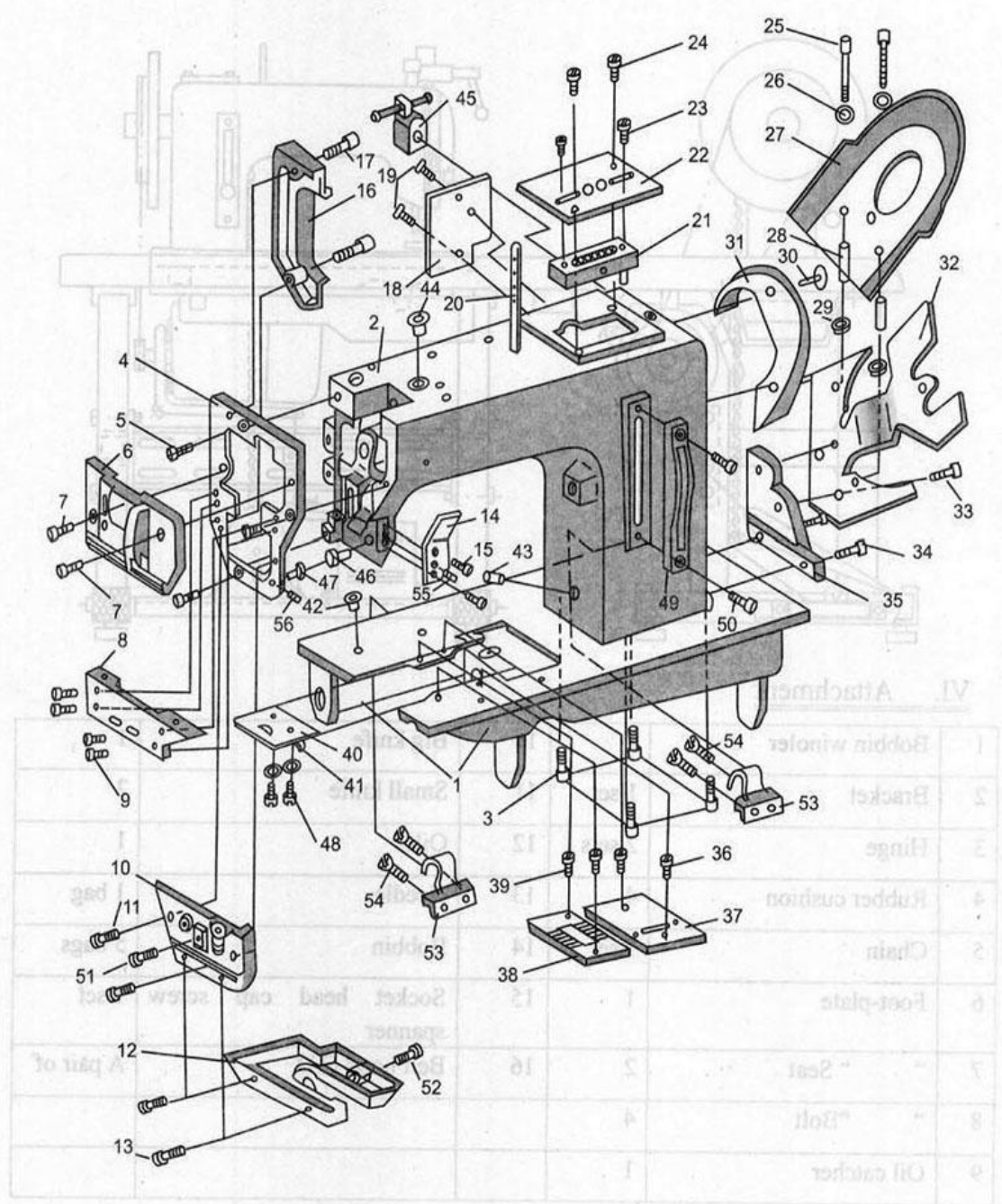

VI. Attachments

1	Bobbin winder
2	Bracket
3	Hinge
4	Rubber cushion
5	Chain
6	Foot-plate
7	"Saw"
8	"Bolt"
9	Oil catcher

VII. Samples of part



## I. Body Unit

No.	No. of drawing	Name of Part	No.	No. of drawing	Name of Part
1	GQ107	Chassis	28	GO100	Belt hood screw saddle Φ10×Φ6.2×40-2
2	GQ106	Body upper segment	29	GL204	Belt hood nut
3	GS136	Body screw M30×35-4 Socket head cap screw	30	GS122	Belt hood 2 screw M4×7.5-2 plain screw
4	GK212	Panel board catching plate	31	GKS101	Belt hood2
5	GS133	Catching plate screw M5×12-2, M5×20-1 Socket head cap screw	32	GK200	Belt hood support
6	GKS103	Panel I Plastic	33	GS134	Belt hood screw
7	GS132	Panel screw M4×16-2 Socket head cap screw	34	GS134	Angle stand screw M6×12-2 Socket head cap screw
8	GK204	Panel II	35	GK199	Angle stand
9	GS132	Panel screw M4×16-4 Socket head cap screw	36	GS172	Connection board screw M5×8-2
10	GKS104	Panel III	37	Gk206	Connection board
11	GS132	Panel screw M4×16-2 Socket head cap screw	38	GM107	Faller
12	GKS207	Oil catching plate	39	GS172	Faller screw M5×8-2
13	GS131	Oil catching plate screw M3×10-1, M3×6-2 Socket head cap screw	40	GK205	Push pedal
14	GK208	Side panel	41	GW100	Push pedal spring
15	GS134	Side panel screw M4×10-2 Socket head cap screw	42	GK209A	Small oil seal
16	GKS102	Side back cover	43	GK209B	Small oil seal without station
17	GS132	“ “ screw M4×40-2 Socket head cap screw	44	GK208	Big oil seal
18	GK202	Back cover plate	45	GK210	Oil pipe joint
19	GS123	“ “ screw M5×9.5-2 plain screw	46	GX102	Pendulum stand spacing pin1
20	GX101	Threading screw	47	GX103	Pendulum stand spacing pin2
21	GK203	Oil box	48	GS121	Push board spring Screw M3×4-2 plain screw Shim Φ6.8×Φ3.2×0.5-2
22	GK201	Upper cover plate	49	GKS105	Stitch cover board
23	GS122	Oil box screw M4×12-2 plain screw	50	GS134	Stitch cover board screw M6×16-2 Socket head cap screw
24	GS123	Upper cover plate screw M5×9.5-2 plain screw	51	GS132	Drawing stand screw M4×8-1 Socket head cap screw
25	GS134	Belt hood screw M6×60-2 Socket head cap screw	52	GS131	Catching oil plate screw M3×10-1 Socket head cap screw
26	GK201	Belt hood washer Φ6×1.5-2	53	GXR222	Hinge 2
27	GKS100	Belt hood 1	54	GS145	M8X20-4 Countersunk screw
			55	GS112	Top wire of Pendulum stand spacing pin M6×6 Grub socket head cap screw
			56	GS113	Top wire of Pendulum stand spacing pin 2 M5×8 Grub socket head cap screw

## 2. Armshaft and thread raising

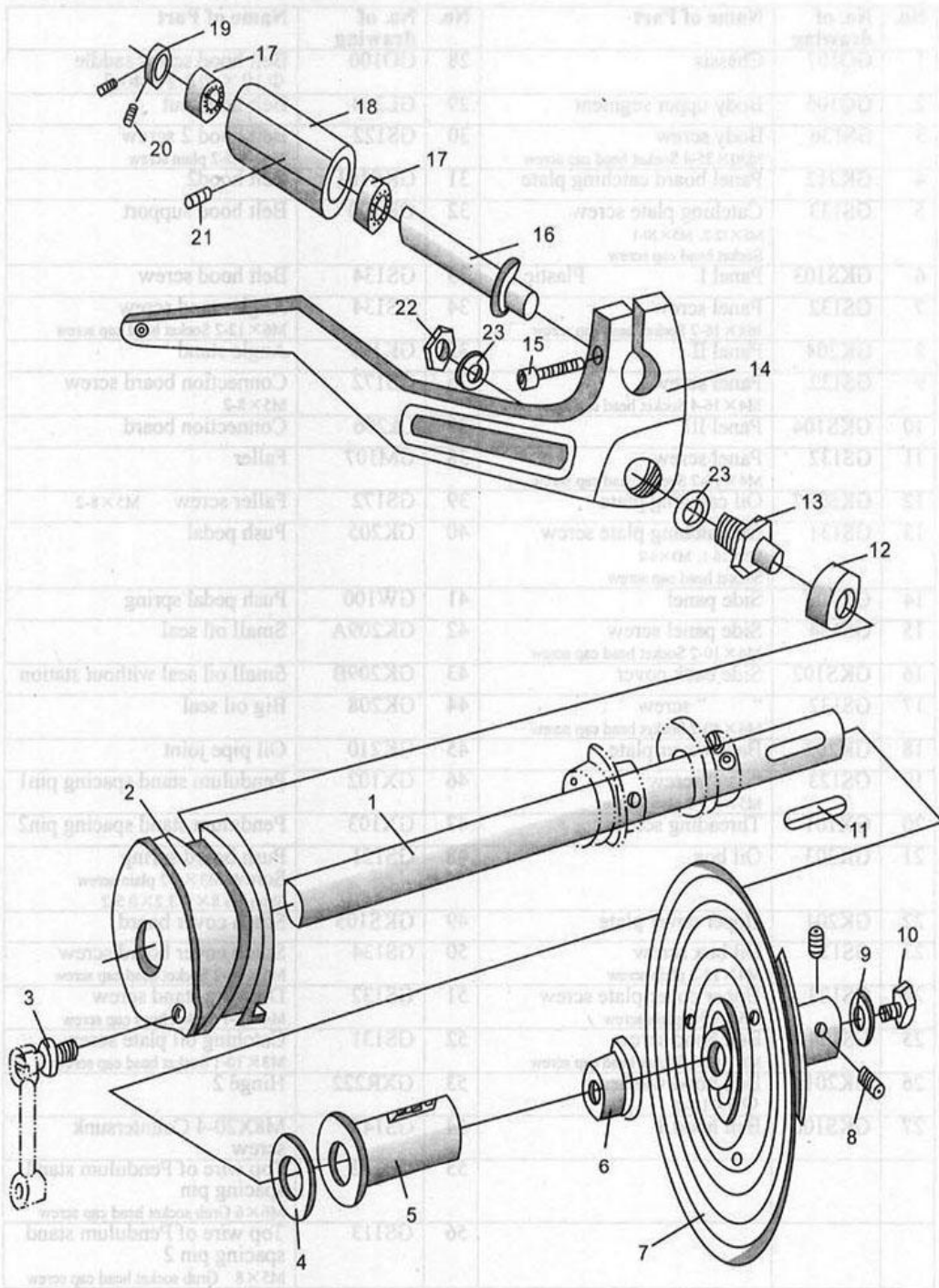

## 2. Armshaft and thread raising

No.	No. of drawing	Name of Part	Quantity	Remark
1	GZ107	Armshaft	1	
2	GP104	Raising thread cam	1	
3	GX100	Raising thread cam connecting rod pin	1	
4	GK215	Front axle sheath shim	1	$\phi 38 \times \phi 16.5 \times 1.5$
5	GO109	Armshaft front axle sleeve	1	
6	GO107	Armshaft back axle sleeve	1	
7	GP103	Big belt pulley	1	
8	GS114	Big belt pulley fastening screw	2	Grub socket head cap screw M8 $\times$ 14
9	GK217	Big belt pulley washer	1	$\phi 15.5 \times \phi 8.52 \times 1.5$
10	GS145	Big belt pulley safety screw	1	Outer hexagon M8 $\times$ 25
11	GH100	Armshaft key	1	5 $\times$ 5 $\times$ 20
12	GZ105	Raising thread rolling wheel	1	
13	GZ105	Raising thread rolling wheel axle	1	
14	GH115	Raising thread rod	1	
15	GS133	Raising thread fastening screw	1	Cylindrical head socket cap screw M5 $\times$ 21
16	GZ106	Raising thread axle		
17	GK09108	Raising thread axle bearing	2	Needle roller bearing HK09108
18	GO101	Raising thread rod axle sleeve	1	
19	GK214	Raising thread axle retainer ring	1	$\phi 18 \times \phi 9.52 \times 8$
20	GS112	Retainer ring fastening screw	2	Grub socket head cap screw M5 $\times$ 5
21	GS113	Raising thread axle sleeve fastening screw	1	Grub socket head cap screw M6 $\times$ 8
22	GL205	Rolling wheel axle locking nut		M8
23	GK280	Raising thread rolling wheel axle collar	2	$\phi 8 \times \phi 14 \times 0.5$



### 3. Needle bar and pendulum presser

Presser

No.	No. of drawing	Name of Part	Quantity	Remark
1	GZ108	Needle bar	1	
2	GH118	Needle bar connecting axle	1	
3	GS133	Needle bar connecting axle screw	2	Socket head cap screw M5×16
4	GS111	Needle fastening screw	1	Grub socket head cap screw M4×5
5	GV2	Needle	1	φ 2.4
6	GH117	Needle bar lifting link	1	
7	GK218	Needle bar synchronous pendulum stand	1	
8	GZ104	Synchronous pendulum stand small axle	1	
9	GK220	Synchronous pendulum stand small axle retainer ring	1	Φ 18× Φ 9.52×8
10	GS101	Retainer ring screw	2	Grub plain screw M5×4
11	GK292	Oil pipe joint	1	
12	GW200	Pendulum stand oil line wire stand	1	
13	GS132	Pendulum stand oil line wire stand screw	1	Socket head cap screw M4×10
14	GS113	Copper link pin fastening screw	1	Grub socket head cap screw M6×6
15	GZ109	Small pressure bar	1	
16	GH119	Pendulum presser lifting small link	1	
17	GH120	Pendulum presser	1	
18	GS132	Pendulum screw	1	Socket head cap screw M4×10
19	GZ135	Copper link pin	1	Φ 6×25

# 4. Presser

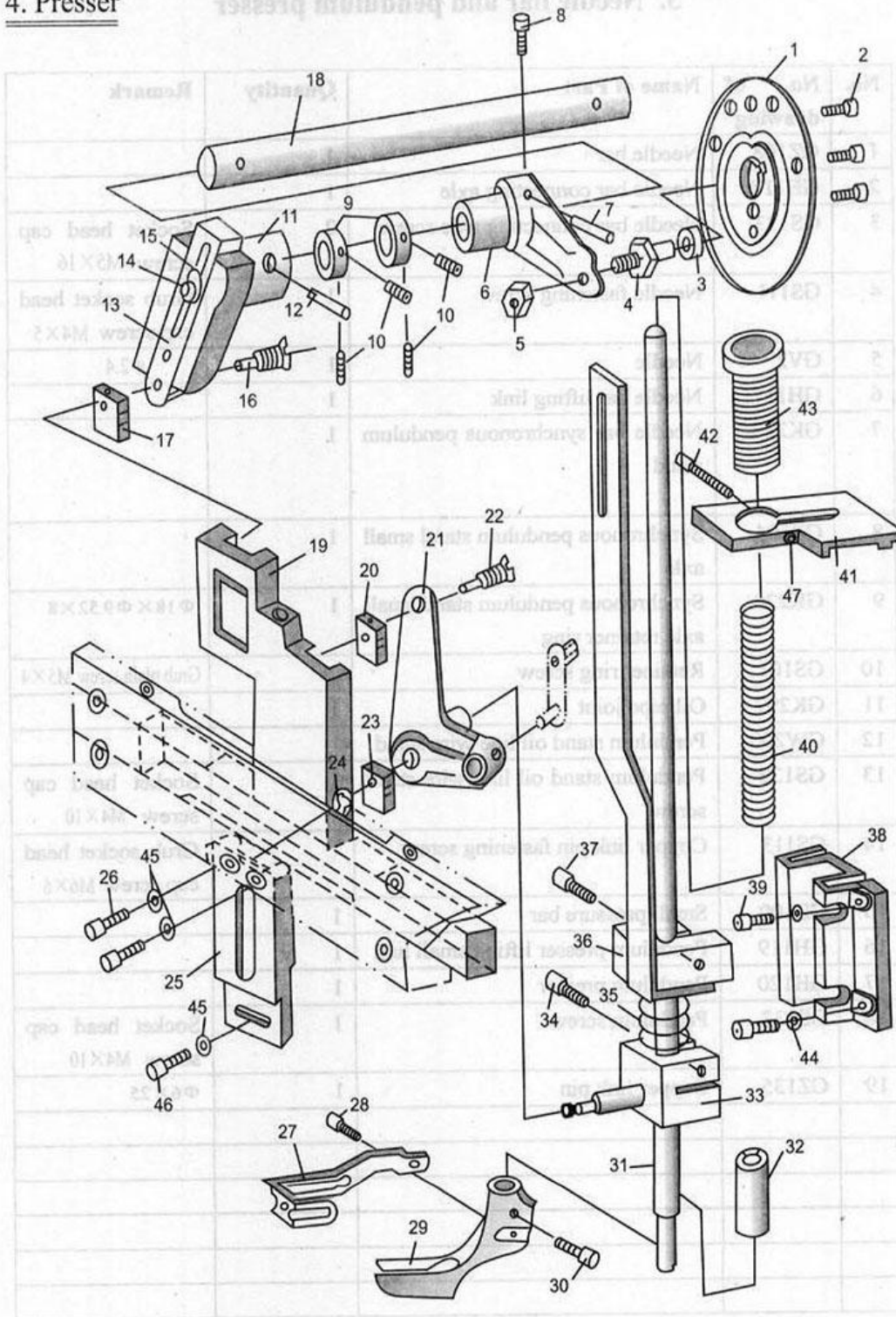

#### 4. Presser

No.	No. of drawing	Name of Part	No.	No. of drawing	Name of Part
1	GP105	Presser lifting curved plate	29	GM104	Compression presser
2	GS134	Curved plate screw M6×18-3 socket head cap screw	30	GS132	Presser screw M4×12 socket head cap screw
3	GU101	Curved plate rolling wheel	31	GZ200	Big presser bar
4	GZ123	Rolling wheel axle	32	GO128	Big presser bar under bush
5	GL205	Rolling wheel axle nut M8	33	GH148	Big presser bar lifting slider
6	GH146	Presser lifting back crank	34	GS134	Lifting slider screw M6×22 socket head cap screw
7	GX104	Back crank taper pin Φ4×27, 1:50	35	GW202	Presser bar small spring
8	GS134	Back crank fastening screw M6×7.5	36	GK221	Presser bar locating piece
9	GK222	Back crank retainer ring 2pcs	37	GS134	Locating piece screw M6×18 socket head cap screw
10	GS112	Retainer ring fastening screw Grub socket head cap screw M5×5	38	GK226	Presser lifting locating slideway
11	GH147	Presser lifting front crank seat	39	GS133	Slideway screw M5×16-2 socket head cap screw
12	GX105	Front crank seat taper pin Φ4×25	40	GW201	Presser bar big spring
13	GU110	Front crank seat slider	41	GKS106	Pressure regulated fastening board
14	GS135	Slider screw socket head cap screw M8×20	42	GS132	Fastening board screw M4×25 socket head cap screw
15	GK223	Screw shim Φ23.5×Φ8.5×2	43	GZ125	Pressure regulated screw
16	GZ124	Front crank slider connecting screw	44	GK227	Slideway screw shim
17	GU111	Copper slider	45	GK228	Stand screw shim
18	GZ122	Presser lifting axle	46	GS133	Stand screw M5×20-1 socket head cap screw
19	GK224	Presser lifting connecting slide board	47	GL206	Fastening board nut
20	GU111	Copper slider			
21	GH141	Presser lifting rocker arm			
22	GZ124	Rocker arm connecting screw			
23	GU111	Copper slider			
24	GW203	Big pressure bar lifting slider jump ring			
25	GK225	Rocker arm stand			
26	GS133	Stand screw M5×16-2 socket head cap screw			
27	GK219	Needle protect stand			
28	GS132	Needle protect stand screw M4×12 socket head cap screw			

## 5. Thread trapping and thread passing

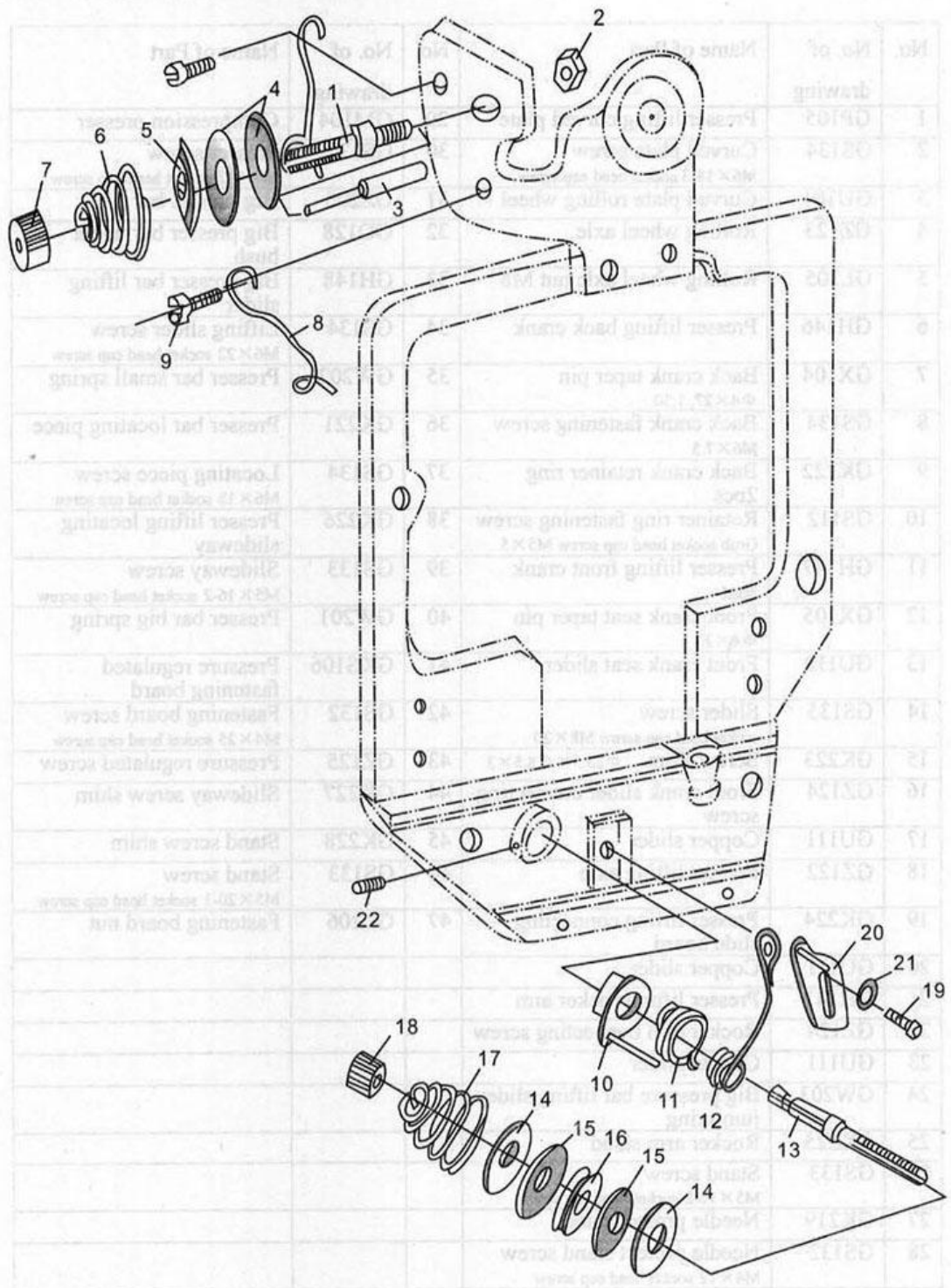

### 5.Thread trapping and thread passing

No.	No. of drawing	Name	Remark
1	GZ126	Thread trapping screw	
2	GL205	Locking nut M8	
3	GX106	Loosen bolt	
4	GK231	Bracket	
5	GK232	Slacker	
6	GW115	Thread trapping spring	
7	GLS204	Thread trapping nut	
8	GK230	Thread passing ring	
9	GS122	Thread passing screw M4×8	Plain screw
10	GKS107	Thread passing seat	
11	GW109	Raising thread spring 2	
12	GW108	Raising thread spring 1	
13	GZ127	Thread passing screw	
14	GK233	Thread passing board	
15	GK234	Thread passing wheel felt ring	
16	GP102	Thread passing wheel	
17	GW102	Thread passing spring	
18	GLS204	Thread passing nut	
19	GS132	Drawing spring stand screw M4×8	Socket head cap screw
20	GKS108	Drawing spring stand	
21	GK235	Drawing spring stand washer	Φ8.8×Φ4.5×0.8---1Pcs
22	GS112	Thread passing fastening screw M5×5	Grub Socket head cap screw



## 6. Bobbin case and bottom axle

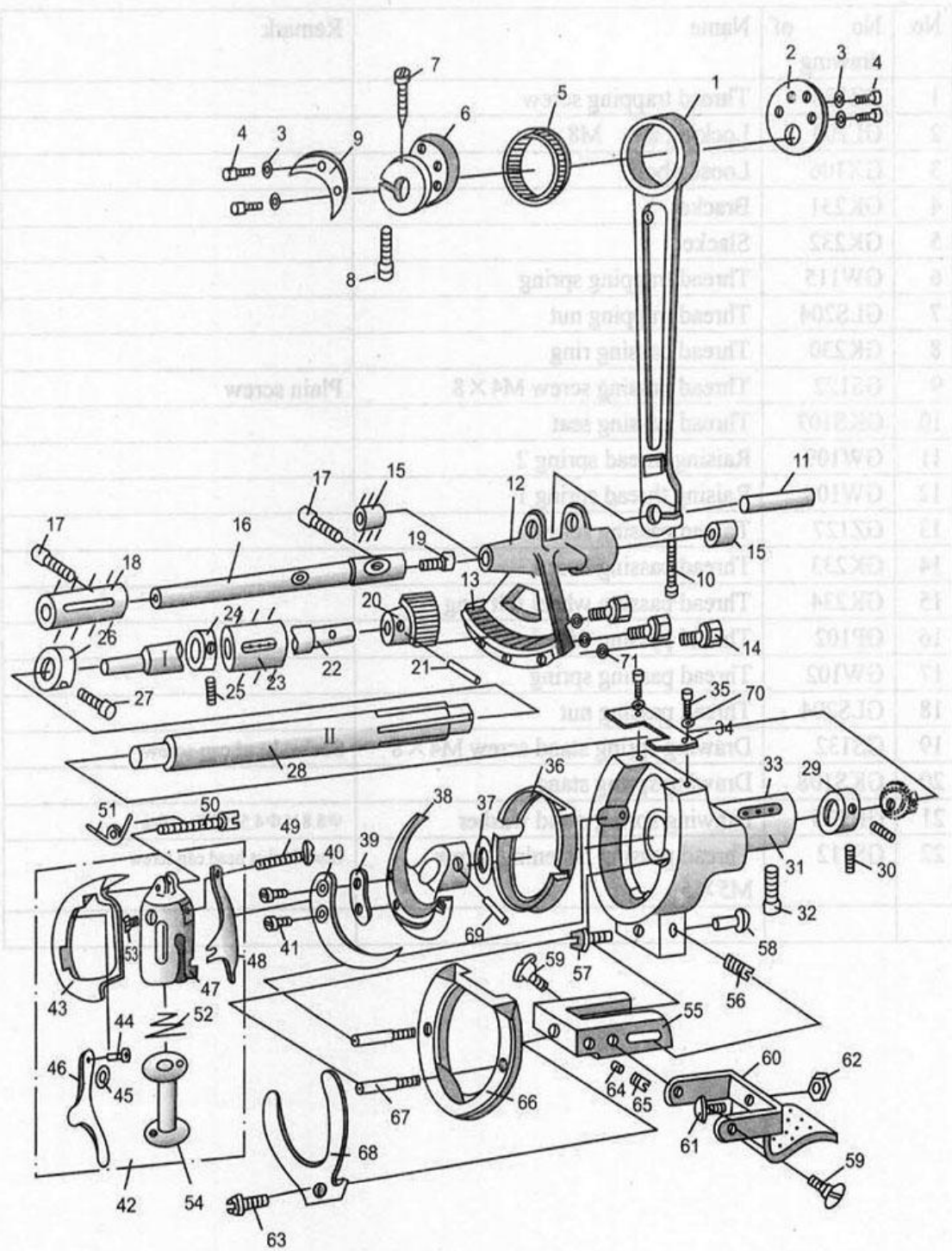

## 6. Bobbin case and bottom axle

No.	No. of drawing	Name of Part	No.	No. of drawing	Name of Part
1	GH129	Big connecting rod body	37	GK295	Pendulum bobbin support shim Φ20.5 × Φ15 × 1.5 1pcs
2	GK236	Eccentric board A	38	GR258	Pendulum bobbin support
3	GK293	Back plate washer Φ7.8 × Φ4.1 × 0.22—4pcs	39	GRS260	Needle protecting retainer shim
4	GS132	Back plate screw M4 × 6 socket head cap screw	40	GR261	Needle protecting retainer
5	HK4512	Rolling needle axle bearing (Φ52 × Φ45 × 12) 4512	41	GR259	Pendulum bobbin support screw Countersunk M3 × 10
6	GO129	Eccentric sleeve	42	GN111/9	Pendulum bobbin
7	GS124	Eccentric sleeve fastening screw M6 × 12 plain screw	43	GN112	Pendulum bobbin body (big back)
8	GS135	Eccentric sleeve trapping screw socket head cap screw M8 × 25	44	GS120	Bobbin bolt screw M2.5 × 4 plain screw
9	GK237	Eccentric board B	45	GN113	Bobbin bolt shim Φ4.5 × Φ2.6 × 0.8 1pcs
10	GS133	Big connecting rod body fastening bolt socket head cap screw M5 × 16	46	GN114	Bobbin bolt
11	GZ128	Big connecting rod pin axle	47	GN115	Bobbin case
12	GK238	Pendulum axle stand	48	GW113	Butterfly bearing spring
13	GP106	Pendulum axle fan-shaped gear	49	GX115	Butterfly bearing spring screw M3 × 16 cup head plain screw
14	GS133	Fan-shaped gear fastening screw socket head cap screw M5 × 12	50	GX116	Bobbin case connecting screw M3 × 22 plain screw
15	GO132	Bottom pendulum axle stand small sleeve	51	GW112	Bobbin case spring
16	GZ111	Bottom pendulum axle	52	GW114	Bobbin bearing spring
17	GS134	Bottom pendulum axle sleeve fastening screw socket head cap screw M6 × 20	53	GS120	Bobbin case screw M2 × 5.5 plain screw
18	GO130	Bottom pendulum axle sleeve	54	GN116	Bobbin
19	GS132	Pendulum axle head screw socket head cap screw M4 × 12	55	GK241	Bobbin bed press stand
20	GP107	Bottom axle small gear	56	GX110	Press stand spiale screw
21	GX107	Small gear taper pin Φ4 × 22 1:50	57	GX109	Press stand shaft position screw
22	GZ112	Bottom axle I	58	GX108	Press stand shaft position pin
23	GO131	Bottom axle sleeve	59	GX112	Spanner spiale screw
24	GK240	Bottom axle I retainer ring	60	GK243	Press stand spanner
25	GS113	Retainer ring fastening screw Grub socket head cap screw M6 × 6	61	GX113	Spanner shaft position screw
26	GZ239	Bottom axle tight ring	62	GL203	Spanner shaft position nut BS11/64 × 40tooth
27	GS113	Bottom axle tight ring fastening screw socket head cap screw M5 × 16	63	GX117	Cover press spring screw
28	GZ113	Bottom axle II	64	GK244	Press stand fastening screw heel
29	GK242	Bottom axle II retainer ring	65	GS102	Press stand fastening screw M5 × 0.5 × 6 plain screw no head
30	GS112	Bottom axle retainer ring fastening screw Grub socket head cap screw M5 × 5	66	GN118	Bobbin bed cover
31	GN117	Bobbin bed seat	67	GS163	Bobbin bed screw
32	GS135	Bobbin bed seat fastening screw socket head cap screw M8 × 35	68	GW111	Cover press spring
33	GK249	Bobbin bed asphalt felt cushion	69	GX121	Pendulum bobbin support taper pin Φ3 × 21 taper 1:50
34	GR262	Needle protecting board	70	GK281	Needle protecting board shim Φ7.8 × Φ4.1 × 0.22—2pcs
35	GS121	Needle protecting board felt cushion M3 × 4 plain screw	71		Fan-shaped gear fastening screw shim
36	GN110	Bobbin bed			

# 7. Feeding

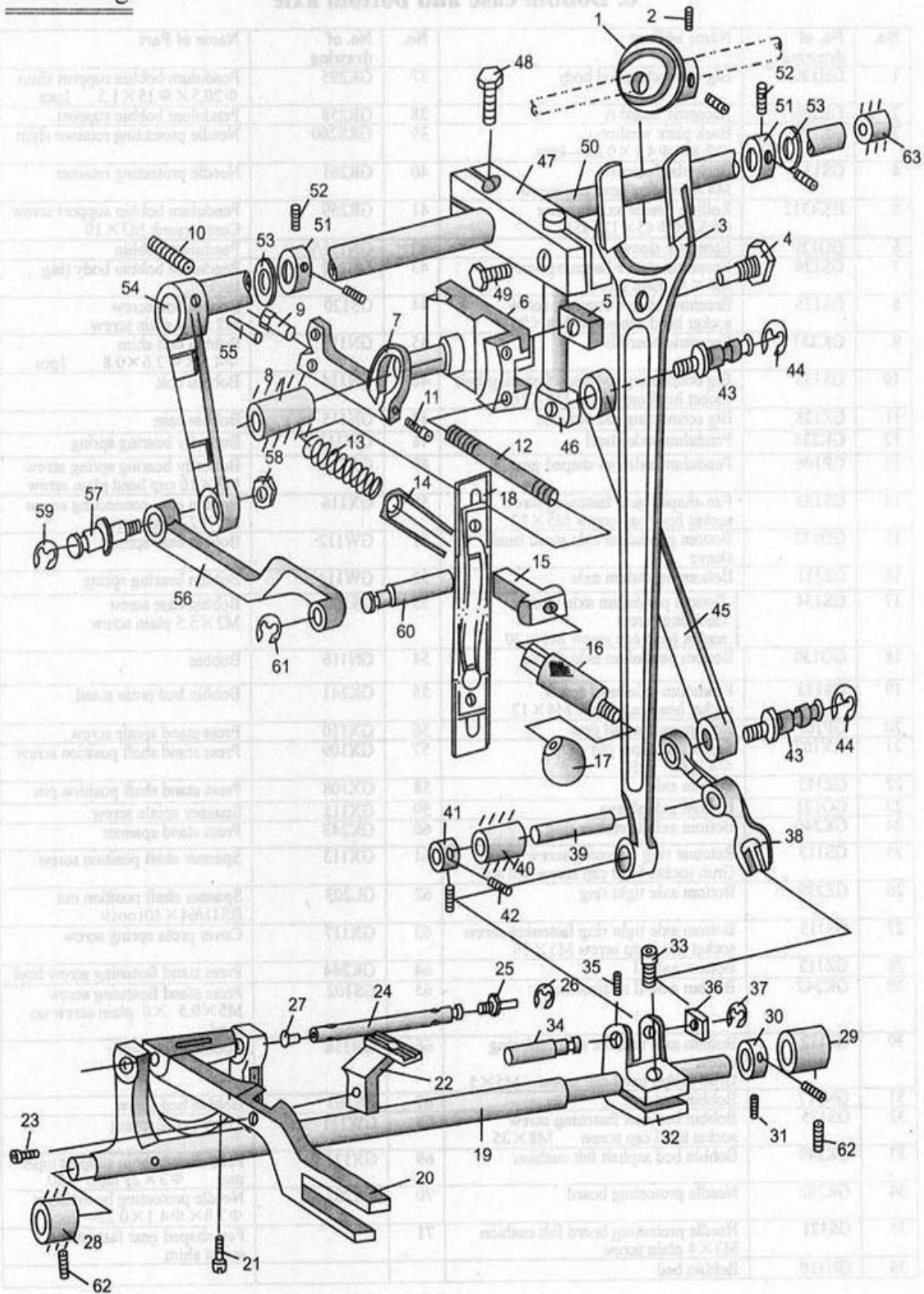

## 7. Feeding

dooT gniif.I 8

No.	No. of drawing	Name of Part	No.	No. of drawing	Name of Part
1	GT103	Feeding cam	35	GS101	Pin axle top wire Grub socket head cap screw M4×4
2	GS113	Feeding cam screw Grub socket head cap screw M6×8	36	GK250	Feeding crank slider
3	GH125	Tooth fork	37	GW204	Slider jump spring $\Phi 7$
4	GZ129	Stitch slider screw	38	GH156	Upper feeding small tooth fork
5	GK245	Stitch seat slider	39	GZ123	Small tooth fork central axle
6	GK246	Stitch seat	40	GO123	Central axle cooper sleeve
7	GK249	Stitch seat fixed stand	41	GK256	Central axle retainer ring
8	GO120	Stitch seat axle sleeve	42	GS112	Central axle retainer ring fastening screw Grub socket head cap screw M5×5
9	GL204	Stitch seat spacing nut	43	GZ133	Upper feeding connecting pin
10	GS113	Stitch seat spacing regulation screw Grub socket head cap screw M6×25	44	GW205	Upper feeding connecting pin jump ring $\Phi 10$
11	GS133	Stitch seat fixed stand locking screw Socket head cap screw M5×20	45	GH155	Upper feeding big connecting bar
12	GZ130	Stitch regulation screw M8	46	GK254	Upper feeding adjustment bar
13	GW210	Stitch regulation spring	47	GH152	Upper feeding back crank seat
14	GW209	Stitch screw sleeve leaf	48	GS145	Upper feeding back crank seat fastening screw M8×25 external hexagon screw
15	GZ131	Stitch spacing sleeve	49	GS145	Upper feeding back crank seat fastening screw M8×18 external hexagon screw
16	GZ132	Stitch regulation screw sleeve	50	GZ120	Upper feeding axle
17	GKS247	Stitch handle ball	51	GK255	Upper feeding axle retainer axle
18	GK248	Stitch spacing board	52	GS113	Upper feeding axle retainer axle fastening screw Grub socket head cap screw M6×6
19	GZ121	Bottom feeding axle	53	GK297	Upper feeding axle shim
20	GK252	Tooth stand	54	GH153	Upper feeding front crank
21	GS123	Tooth stand fastening screw M5×7.5 plain screw	55	GX118	Upper feeding front crank taper pin $\Phi 4 \times 26$ 1:50
22	GM106	Machine tooth	56	GH151	Copper connecting bar
23	GS123	Machine tooth screw M5×12 plain screw	57	GZ134	Front crank copper connecting bar pin
24	GZ122	Tooth stand axle	58	GL204	Front crank copper connecting bar pin nut M6
25	GK296	Oil pipe small joint	59	GW206	Front crank copper connecting bar pin jump spring $\Phi 8$
26	GW208	Tooth stand axle jump ring $\Phi 8$	60	GZ135	Pendulum stand copper connecting bar pin
27	GKS253	Tooth stand oil seal	61	GW207	Pendulum stand copper connecting bar pin jump spring $\Phi 6$
28	GO122	Bottom feeding axle front axle sleeve	62	GS113	Axle sleeve fastening screw Grub socket head cap screw M6× 10
29	GO121	Bottom feeding axle back axle sleeve	63	GO124	Upper feeding axle back axle sleeve
30	GK251	Bottom feeding retainer ring			
31	GS113	Bottom feeding axle back axle sleeve retainer ring screw Grub socket head cap screw M6×10			
32	GH154	Bottom feeding back crank			
33	GS134	Bottom feeding axle back axle sleeve fastening screw socket head cap screw M6×10			
34	GX117	Feeding crank slider pin axle			



## 8. Lifting Tooth

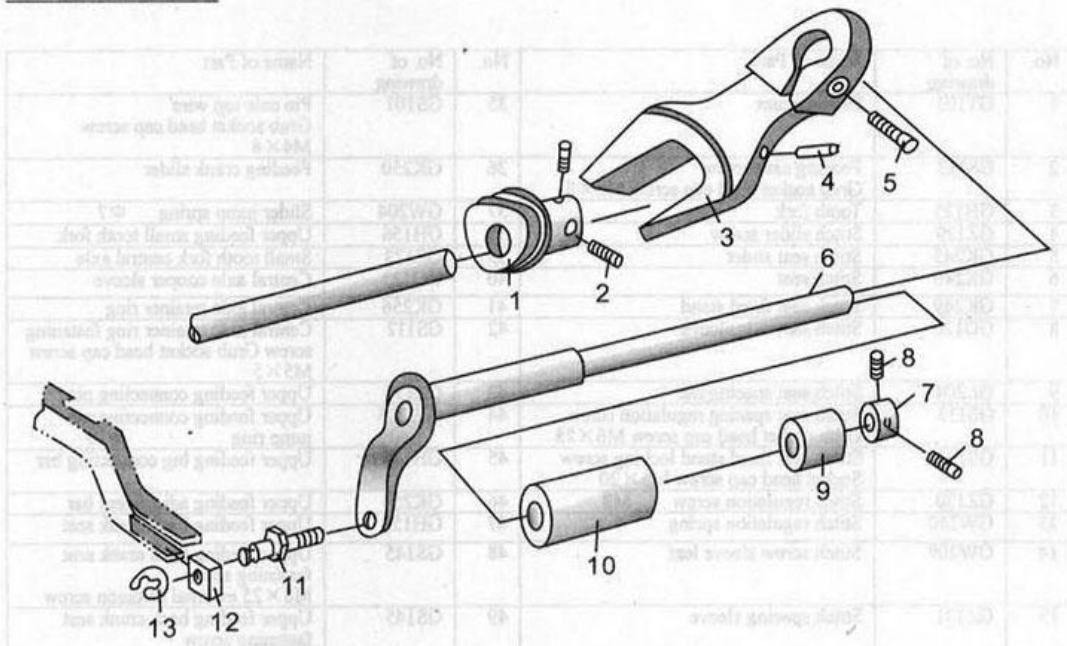

8. Lifting Tooth

No.	No. of drawing	Name	Remark
1	GT104	Lifting tooth cam	
2	GS113	Cam fastening screw M6×6 Grub socket head cap screw	
3	GH132	Lifting tooth fork	
4		Oil pipe joint	
5	GS134	Tooth fork fastening screw M6×22 Grub socket head cap screw	
6	GZ223	Lifting tooth axle	
7	GK257	Lifting tooth axle retainer ring	
8	GS112	Retainer ring fastening screw M5×6 Grub socket head cap screw	
9	GO112	Lifting tooth axle back sleeve	
10	GO113	Lifting tooth axle front sleeve	
11	GZ136	Lifting tooth slider pin	
12	GU111	Copper slider	
13	GW203	Lifting tooth axle jump ring Φ5.5	



# 9. Presser lifter

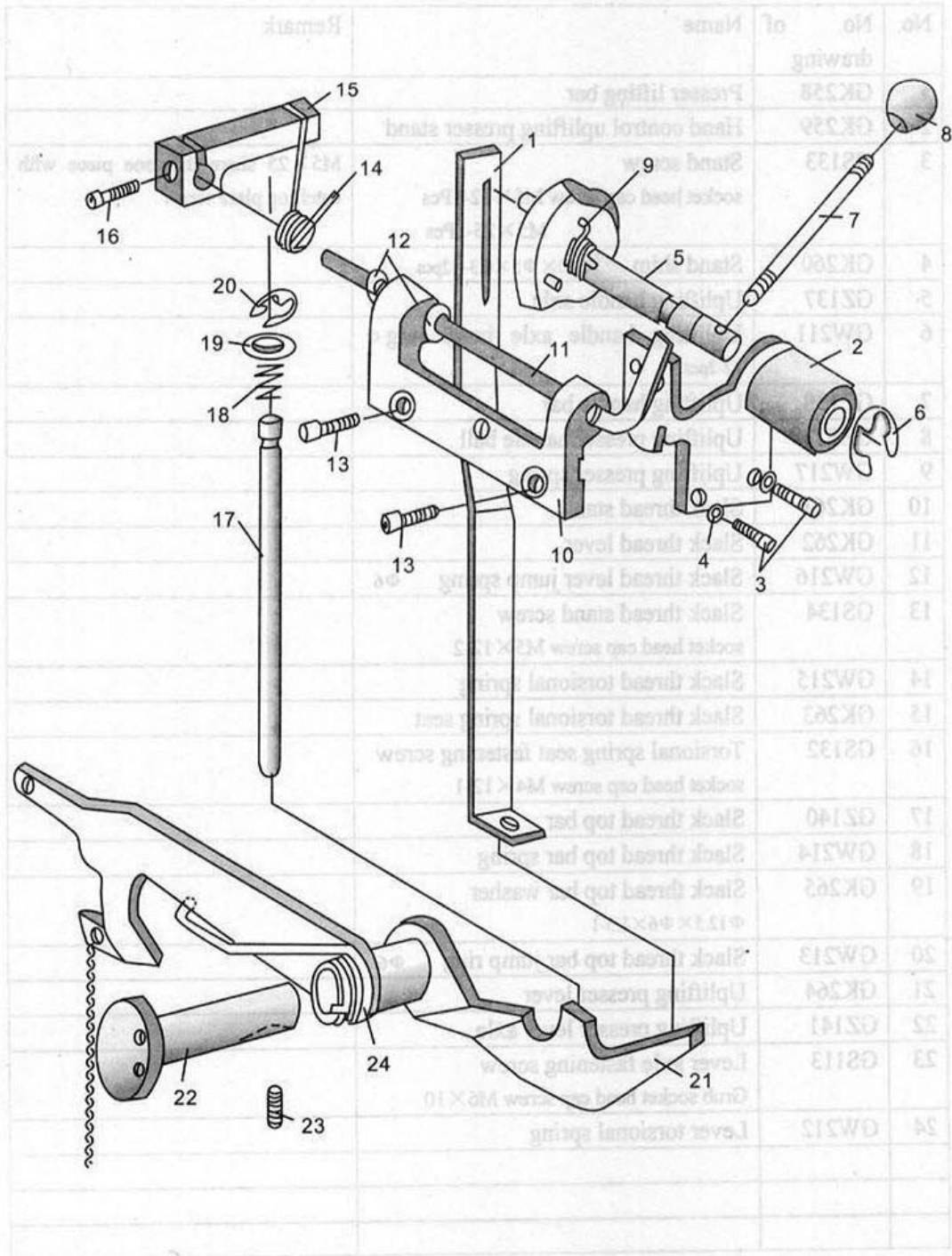

## 9. Presser lifter

9. Presser lifter

No.	No. of drawing	Name	Remark
1	GK258	Presser lifting bar	
2	GK259	Hand control uplifting presser stand	
3	GS133	Stand screw socket head cap screw M5×12-1Pcs M5×25-1Pcs	M5×25 share this one piece with catching plate screw
4	GK260	Stand shim $\Phi 10 \times \Phi 5 \times 0.3$ —2pcs	
5	GZ137	Uplifting handle axle	
6	GW211	Uplifting handle axle jump ring $\Phi 12$ -2pcs	
7	GZ138	Uplifting handle bar	
8	GZS139	Uplifting presser handle ball	
9	GW217	Uplifting presser spring	
10	GK261	Slack thread stand	
11	GK262	Slack thread lever	
12	GW216	Slack thread lever jump spring $\Phi 6$	
13	GS134	Slack thread stand screw socket head cap screw M5×12-2	
14	GW215	Slack thread torsional spring	
15	GK263	Slack thread torsional spring seat	
16	GS132	Torsional spring seat fastening screw socket head cap screw M4×12-1	
17	GZ140	Slack thread top bar	
18	GW214	Slack thread top bar spring	
19	GK265	Slack thread top bar washer $\Phi 12.5 \times \Phi 6 \times 1.5$ -1	
20	GW213	Slack thread top bar jump ring $\Phi 6$	
21	GK264	Uplifting presser lever	
22	GZ141	Uplifting presser lever axle	
23	GS113	Lever axle fastening screw Grub socket head cap screw M6×10	
24	GW212	Lever torsional spring	

10. Bobbin winder

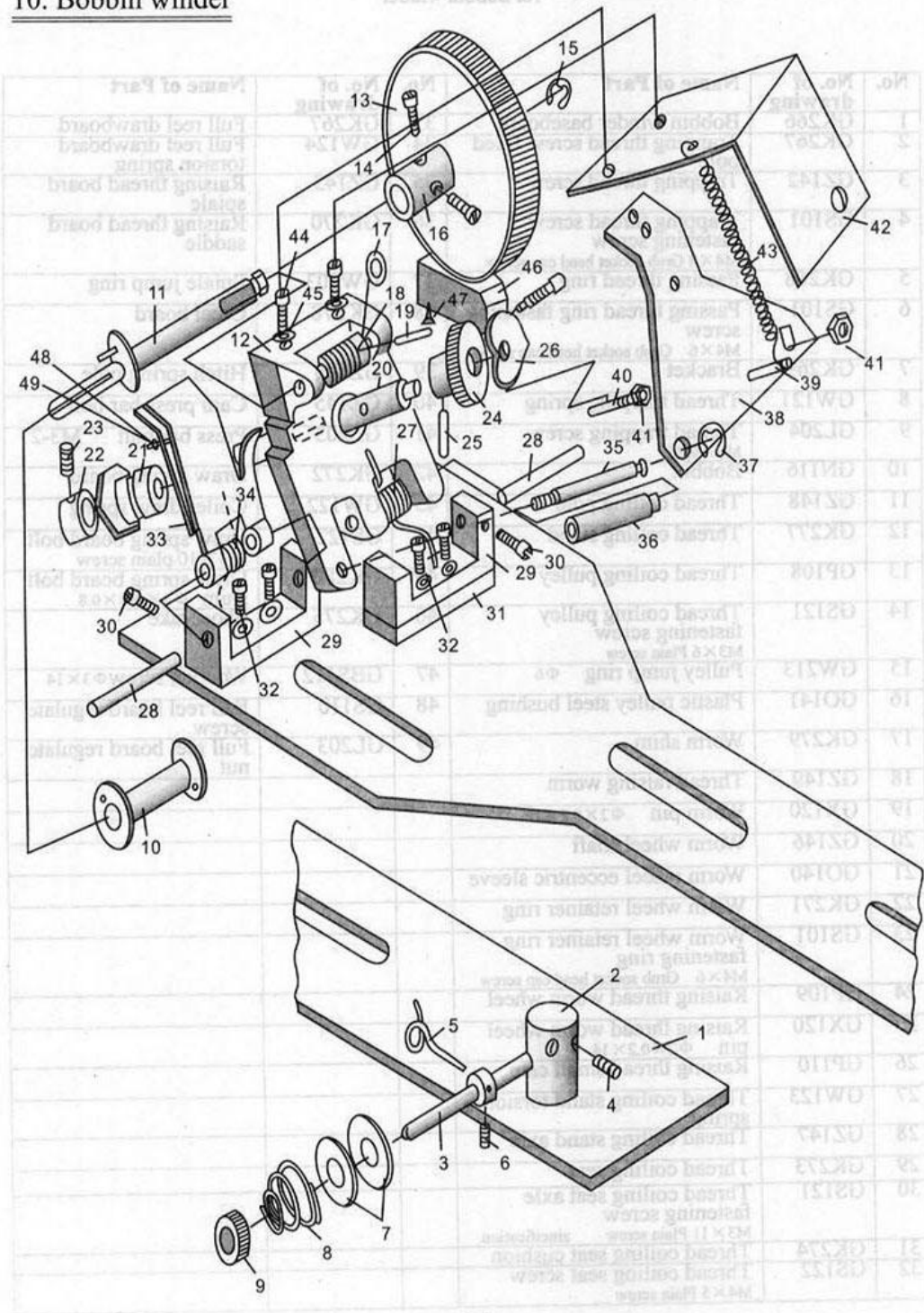

10. Bobbin winder

10. Bobbin winder

No.	No. of drawing	Name of Part	No.	No. of drawing	Name of Part
1	GK266	Bobbin winder baseboard	33	GK267	Full reel drawboard
2	GK267	Trapping thread screw fixed pole	34	GW124	Full reel drawboard torsion spring
3	GZ142	Trapping thread screw	35	GZ143	Raising thread board spiale
4	GS101	Trapping thread screw fastening screw M4×8 Grub socket head cap screw	36	GK270	Raising thread board saddle
5	GK268	Passing thread ring	37	GW203	Spiale jump ring
6	GS101	Passing thread ring fastening screw M4×6 Grub socket head cap screw	38	GK278	Creel board
7	GK269	Bracket	39	GZ144	Hitch spring pole
8	GW121	Thread trapping spring	40	GZ145	Cam press bar bolt
9	GL204	Thread trapping screw M6×0.75	41	GL203	Press bar bolt M3-2
10	GN116	Bobbin	42	GK272	Draw spring board
11	GZ148	Thread coiling pole	43	GW122	Coiler draw spring
12	GK277	Thread coiling stand	44	GS122	Draw spring board bolt M4×10 plain screw
13	GP108	Thread coiling pulley	45	GK280	Draw spring board bolt shim Φ4×Φ8×0.8
14	GS121	Thread coiling pulley fastening screw M3×6 Plain screw	46	GK275	Shoebreak
15	GW213	Pulley jump ring Φ6	47	GBS112	Wooden screw Φ3×14
16	GO141	Plastic pulley steel bushing	48	GS110	Full reel board regulate screw
17	GK279	Worm shim	49	GL203	Full reel board regulate nut
18	GZ149	Thread raising worm			
19	GX120	Worm pin Φ2×0.2×10			
20	GZ146	Worm wheel shaft			
21	GO140	Worm wheel eccentric sleeve			
22	GK271	Worm wheel retainer ring			
23	GS101	Worm wheel retainer ring fastening ring M4×6 Grub socket head cap screw			
24	GP109	Raising thread worm wheel			
25	GX120	Raising thread worm wheel pin Φ2×0.2×14			
26	GP110	Raising thread small cam			
27	GW123	Thread coiling stand torsion spring			
28	GZ147	Thread coiling stand axle			
29	GK273	Thread coiling seat			
30	GS121	Thread coiling seat axle fastening screw M3×11 Plain screw zincification			
31	GK274	Thread coiling seat cushion			
32	GS122	Thread coiling seat screw M4×5 Plain screw			

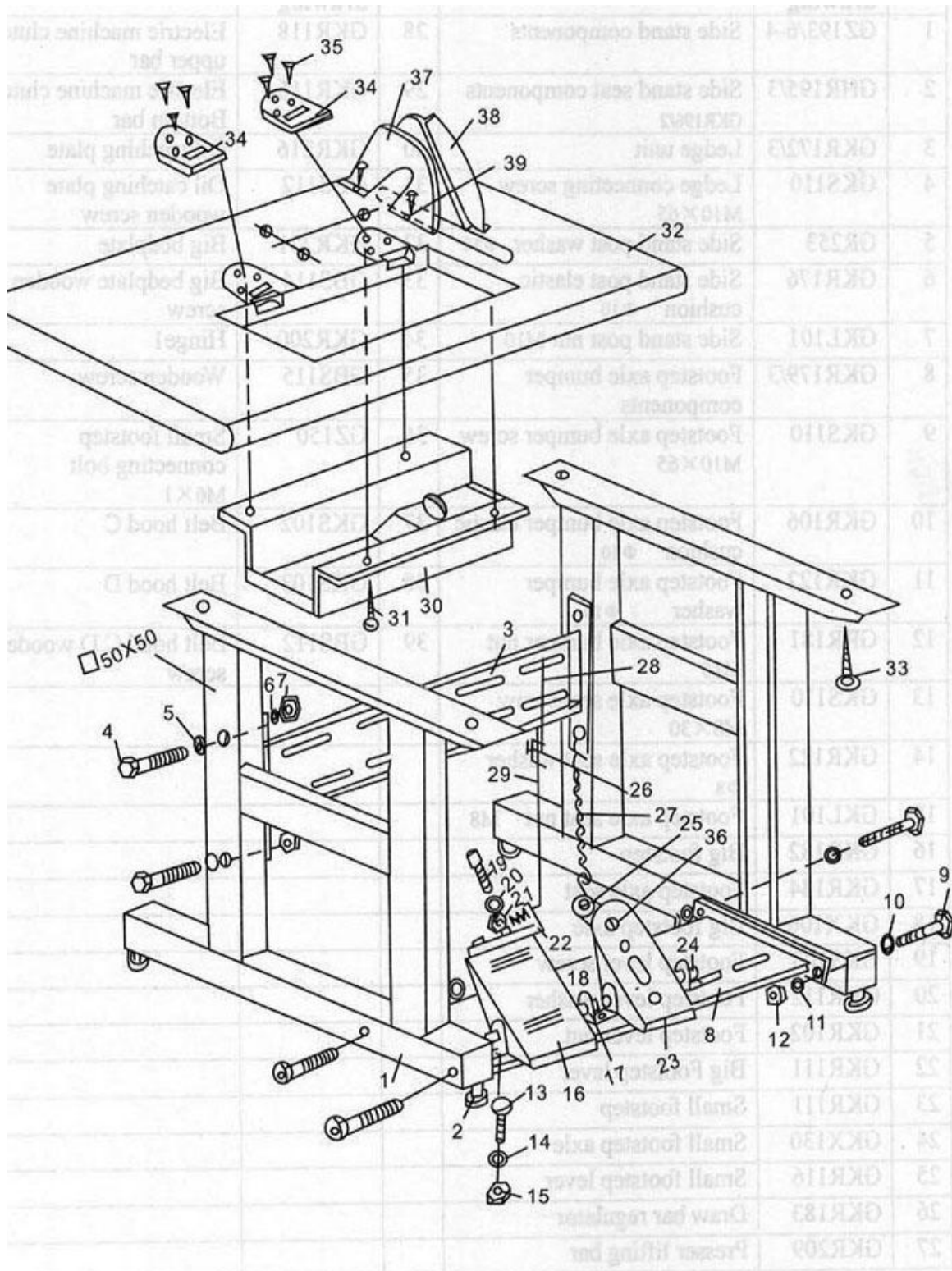



## 11. Components of frame

No.	No. of drawing	Name of Part	No.	No. of drawing	Name of Part
1	GZ193/6-4	Side stand components	28	GKR118	Electric machine clutch upper bar
2	GHR195/3	Side stand seat components	29	GKR116	Electric machine clutch Bottom bar
3	GKR172/3	Ledge unit	30	GKR216	Oil catching plate
4	GKS110	Ledge connecting screw M10×65	31	GBS112	Oil catching plate wooden screw
5	GR253	Side stand post washer $\phi 10$	32	GKR221	Big bedplate
6	GKR176	Side stand post elastic cushion $\phi 10$	33	GBS114	Big bedplate wooden screw
7	GKL101	Side stand post nut M10	34	GKR200	Hinge1
8	GKR179/3	Footstep axle bumper components	35	GBS115	Wooden screw
9	GKS110	Footstep axle bumper screw M10×65	36	GZ150	Small footstep connecting bolt M6×1
10	GKR106	Footstep axle bumper elastic cushion $\phi 10$	37	GKS102	Belt hood C
11	GKR122	Footstep axle bumper washer $\phi 10$	38	GKS103	Belt hood D
12	GRR181	Footstep axle bumper nut M10	39	GBS112	Belt hood C.D wooden screw
13	GKS110	Footstep axle seat screw M8×30			
14	GKR122	Footstep axle seat washer $\phi 8$			
15	GKL101	Footstep axle seat nut M8			
16	GKR182	Big footstep			
17	GKR184	Footstep axle seat			
18	GKX106	Big footstep axle			
19	GKS103	Footstep lever screw			
20	GKR112	Footstep lever washer			
21	GKR102	Footstep lever nut			
22	GKR111	Big Footstep lever			
23	GKR111	Small footstep			
24	GKX130	Small footstep axle			
25	GKR116	Small footstep lever			
26	GKR183	Draw bar regulator			
27	GKR209	Presser lifting bar			

## VIII. Operation Method and Adjustment

### 1. Installation of Needle

Turn the hand wheel by right hand, so the needle bar will go up the highest position; loosen the fastening screw of the needle, insert the needle with the handle above into the bottom of the hole of needle bar; when the long groove of needle towards left (facing outside), screw the fastening screw of needle.

### 2. Take out bobbin (Figure 1)

Turn the upper wheel, so the raising thread bar will go up the highest point, press the bobbin bolt (GN114) by right hand and move the bobbin case (GN115) by left hand, make it slope to outside, so the bobbin (GN116) will be taken out.

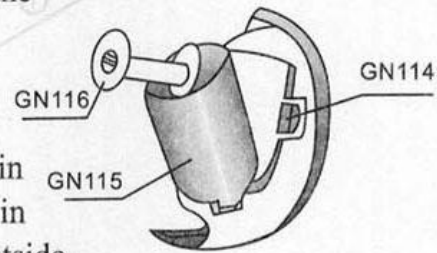

(Figure 一)

### 3. Coiling bobbin

Fix the bobbin winder on the right platen of machine. Drive belt drives the coiling wheel. When coiling, interlink the bobbin on the coiling post, push it into inside tightly, pull out the suture from the ball of string, cross the over thread ring and bracket on the bobbin winder; pull out the end of a thread from the hole at the upper of creel board and coiling a few circle on the bobbin. Press the bobbin by the full thread draw board, make the coiling wheel close to the drive belt, when the machine go into operation, the bobbin will be coiling automatically. When the bobbin is full, the coiling wheel will be separated automatically, the coiling is stop.

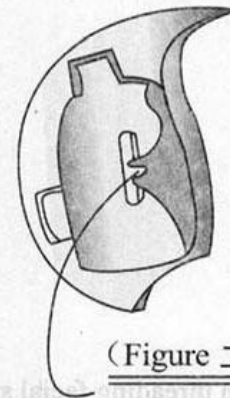

(Figure 二)

Must point out: when coiling, the machine can't sew.

### 4. Threading the Pendulum Bobbin (Figure 2)

Pull out a part of thread, and put the bobbin into bobbin case (GN115), press the end of thread under the butterfly spring (GN113), slide thread along the groove of bobbin case into the stick thread hold, then pull out the end of thread about 50mm from bobbin spring, at last, press the bobbin case fixed with bobbin will into the pendulum bobbin.

## 5. Threading the Facial Suture

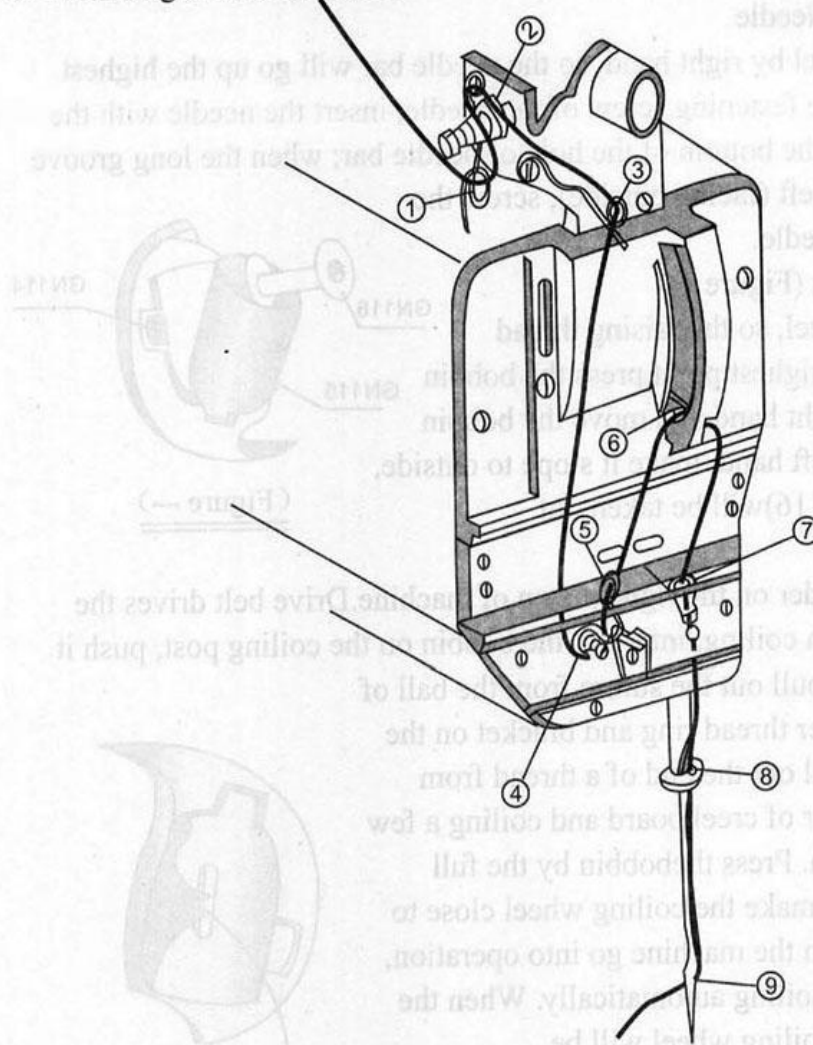

When threading facial suture, the needle bar should be at the highest position, then extract the thread from a reel of thread, threading according to the following order:

- 1). Threading the extracted thread through the thread-passing ring ①, pass the bracket ② upward, through the thread-passing ring ③ downward;
- 2). Circle the thread-passing wheel ④ in counter-clockwise direction, through the raising-thread spring ⑤ upward;
- 3). Through the threading hole ⑥ of raising thread bar from left to right, pass the threading hole ⑦ on the panel downward;
- 4). Pass the thread from the inside of panel to the hole on the needle barplate ⑧, at last through the needle hole from the front of needle, pull out the thread about 50-100mm for use.

## 6. Regulation of Suture's Tension

The tension of suture affects the quality of stitches directly. The correct suture tension should make the facial suture and the bobbin thread twisted in the middle of the sewing material (Middle Figure), if the facial suture tension is big, but the bobbin thread is small, the loose facial thread will be sewed in straight line on the surface of material (Upper Figure), otherwise the bobbin thread will be sewed in straight line (Under Figure). If the facial thread is nipped by two brackets, change the tension of facial thread by regulating the trapping nut (GLS204); change the tension of the bobbin thread by regulating the pressure of the butterfly spring.

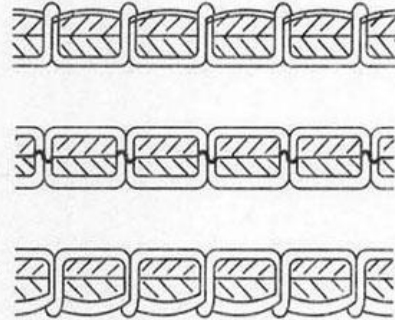

(Figure 三)

## 7. Regulation of Presser's Pressure

Presser is used in helping the feeding tooth to push the material. The pressure of presser should be defined by the property or thick or thin of sewing material. If the presser is over, the sewing material will be crompt, if it is too small, it can not feeding. When sewing thick material, turn the pressure regulated screw on the top of head in clockwise sense to increase the pressure; when sewing thin material, turn the pressure regulated screw on the top of head in counter-clockwise direction to decrease pressure.

## 8. Regulation of Stitch

As the different use of sewing material, the stitches must be adjusted. In general, the stitches should be large for sewing thick material, and small for thin or soft material. When regulating stitches, turn the stitch regulating blind sleeve (GZ132) in counter-clockwise direction, the stitches will become large; turn the stitch regulating blind sleeve (GZ132) in clockwise direction, the stitches will become small. When make back sewing, move the blind sleeve to the above of null line in counter clockwise direction. If the stitches changed in the process of sewing, screw the spacing nut (GL204) of stitch seat at the back of machine.

## 9. Regulation of Height of Needle Bar

The height of needle bar is very important. If it is too high, the thread will jump, conversely, the thread will be broken. The new customer should better not move that, the professional person should them if the unusual phenomenon occurs.

## 10. Adjustment of Height of Feeder

When the feeding tooth need to be adjusted, loosen the screw under the feeding tooth, when it moves to the correct position, screw the bolt again.