

# **ROMITEX**

háztartási hólozó varrógép

## **GÉPKÖNYV**

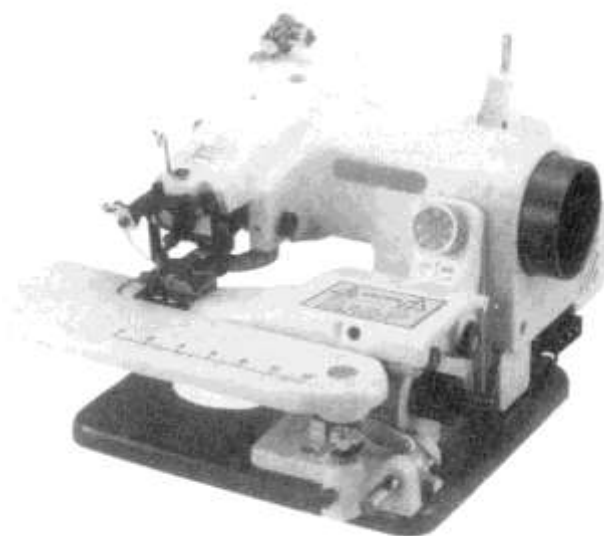

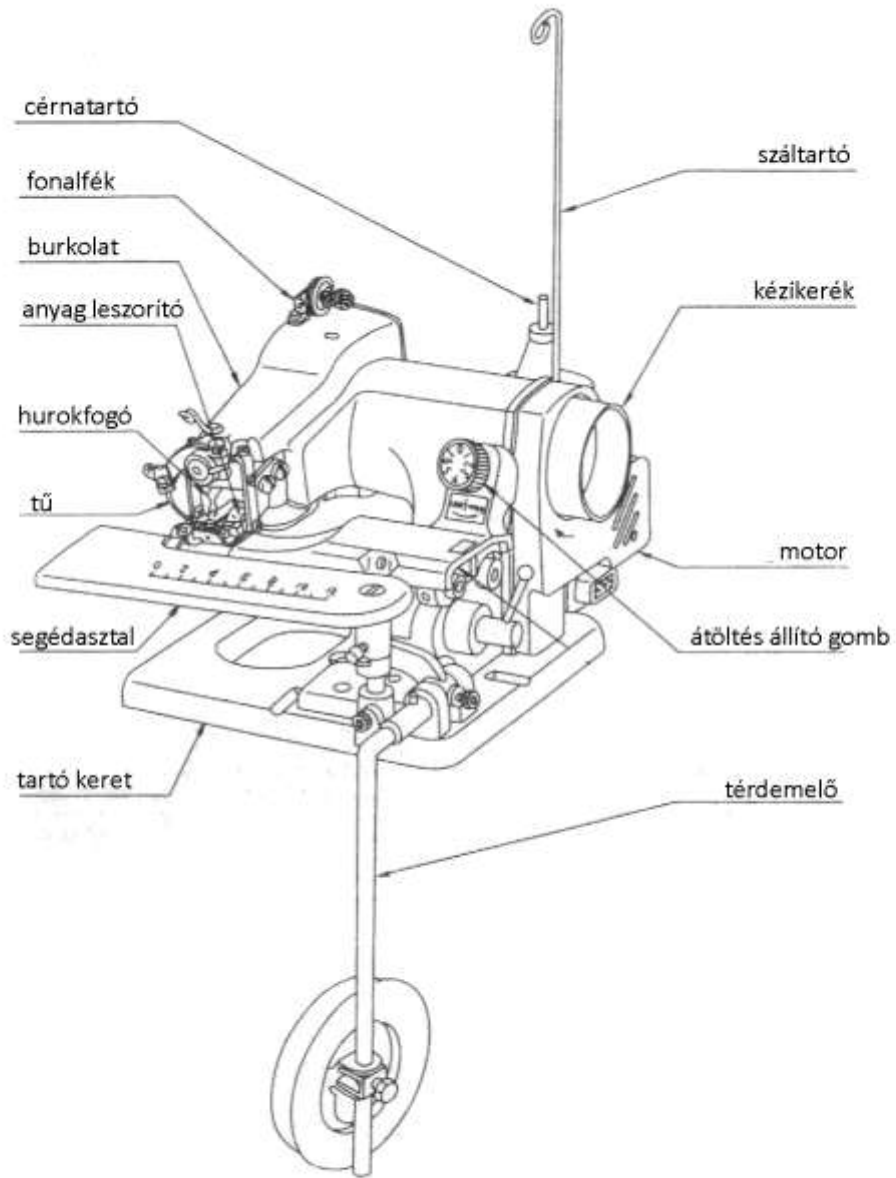

**1. A gép rögzítése a tárgyasztalhoz.**

A gépet helyezzük az asztal szélére úgy, hogy a keret az asztal szélével egy vonalban legyen. Majd a leszorító pálcával rögzítjük a gépet az 1. ábra szerint. A gép másik oldalát a másik rögzítő pálcával merőlegesen az 1-esre rögzítjük a 2. ábra szerint.

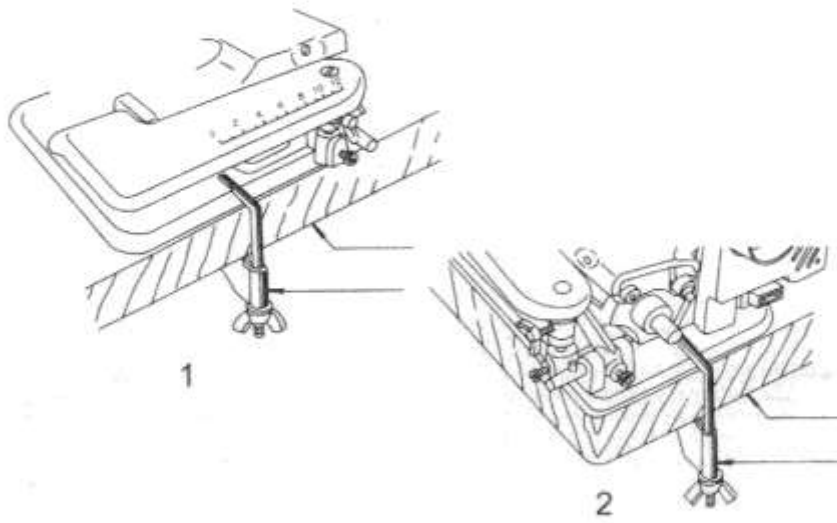

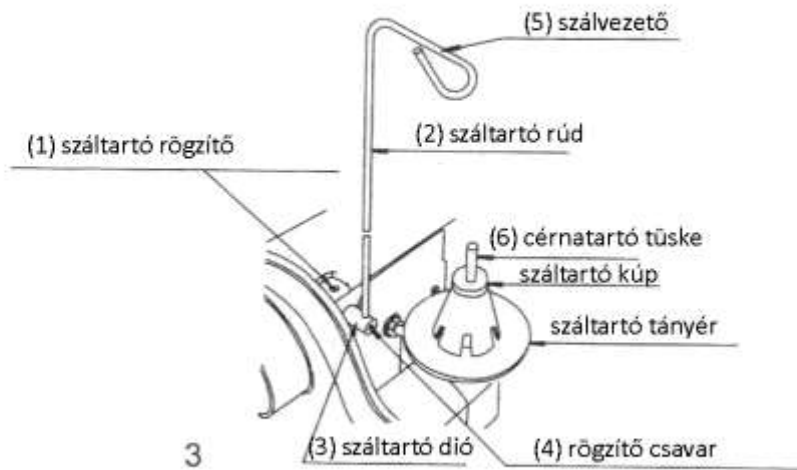

**C. Indító pedál csatlakoztatása a géphez.**

Az indító pedál vezetéknek a géphez csatlakozó oldalát a kézi kerék alatt lévő aljzatba dugjuk be. A másik csatlakozót a hálózati 230V-os konnektor aljzatba. Az indítópedál lenyomásával a gép indul.

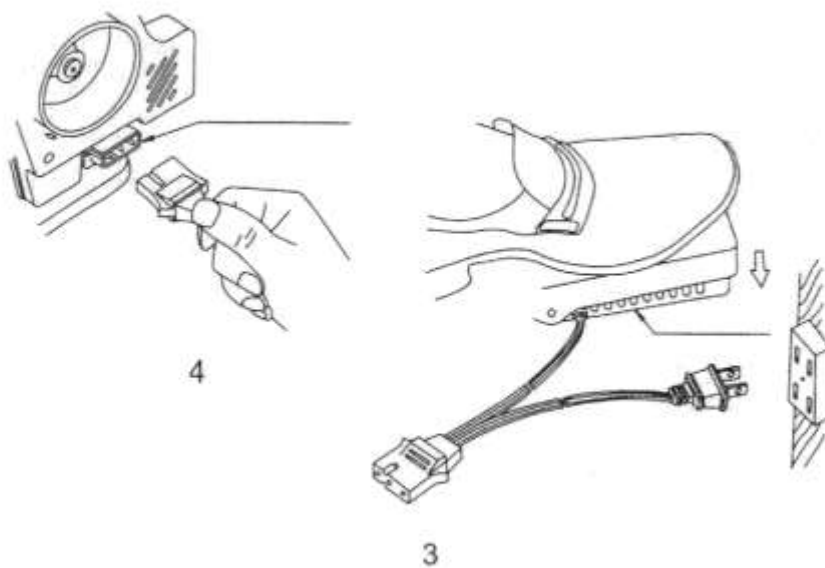

### 6. Térdemelő felhelyezése

A térdemelő kart (1) csúsztassuk fel a térdemelő csapra (2) úgy, hogy a térdemelő kar nyílása a térdemelő csapon lévő ütközőre (3) rácsússzon.

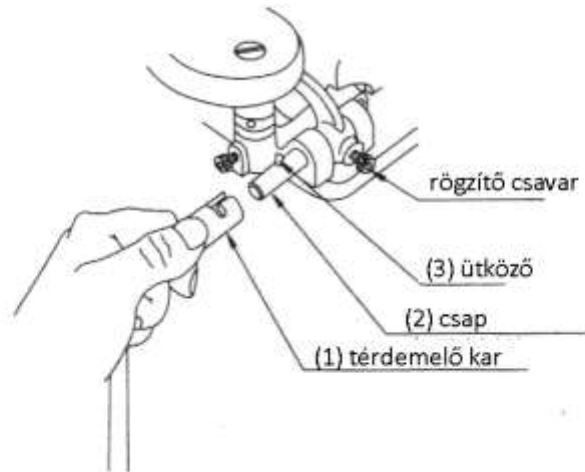

3. Olajzási pontok (7. ábra)

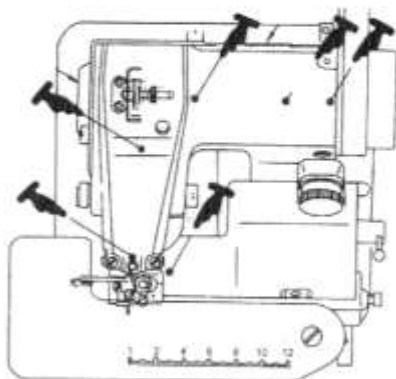

7

**Tűtípus**  
LW x 6T

Tű vastagság:

SIZE 3(11)	NO.80 - 100
SIZE 3 1/2(14)	NO.60 - 70
SIZE 4(16)	NO.50 - 60

5

#### 4. Tűcsere

A tű rögzítő csavart (1) lazítsuk meg, majd a tűt vegyük ki a helyéről, az új tűt pedig helyezze vissza a tartó karba (2) és a rögzítő csavart szorítsa meg.

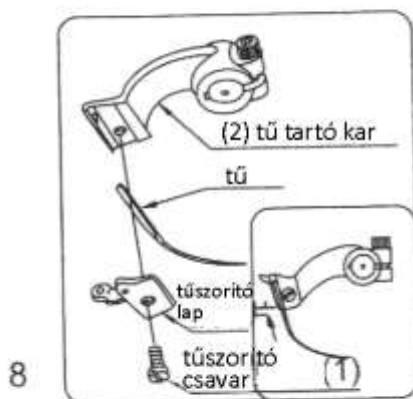

#### 5. Befűzés

Helyezzük a cérnát a száltartóra, majd kövessük a 9-es ábra szerinti befűzést.

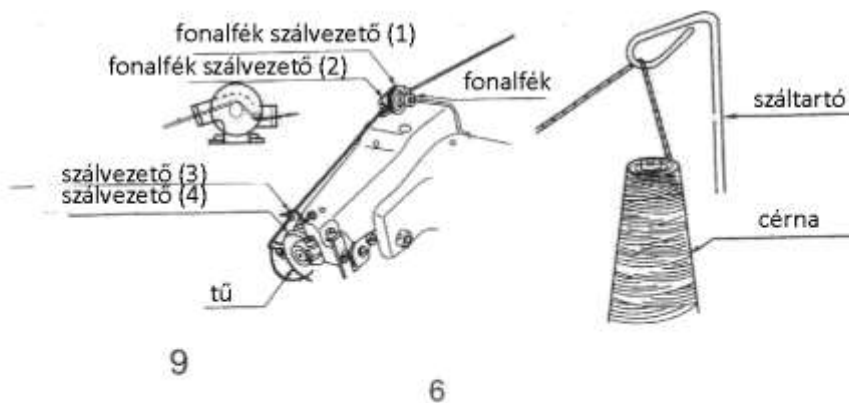

A cérna elhelyezése a 10-es ábrán látható.

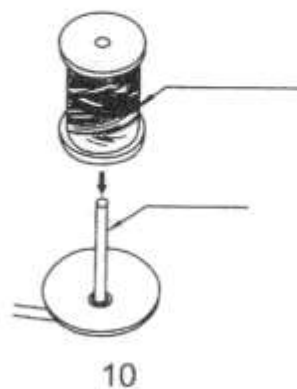

**A tű befűzése,** a 11-es ábra szerint.

**A segédszta rögzítése.**

A segédszta nyitható, amennyiben szűk ujját vagy gyermek ruhát hólozunk, a segédszta akadályozná a munkát, úgy ki lehet fordítani és külső állásba rögzíteni a 12 ábra szerint.

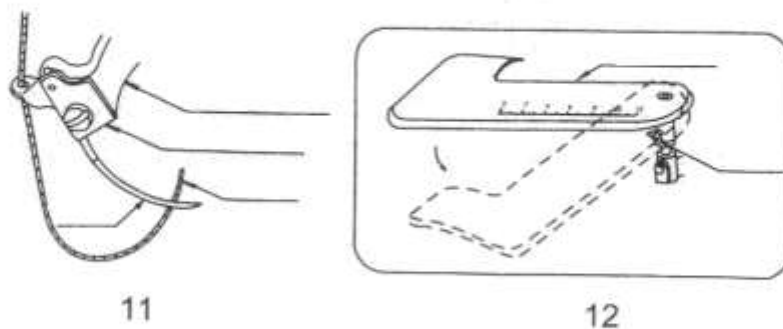



6. Helyezzük a kelmét a gép varróalpára, úgy hogy a behajtott rész felül legyen, a 13-as ábra szerint.

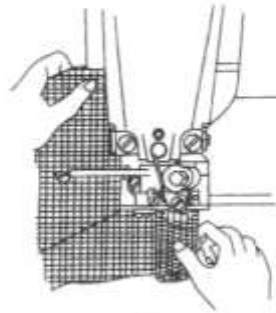

13

A kelmét varráshoz az alábbi két ábra szerint kell kezelni. Az egyik (14-1) a visszahajtott anyag szélét rögzíti a testhez. A másik (14-2) pedig magát a visszahajtott anyagot is rögzíti a testhez.

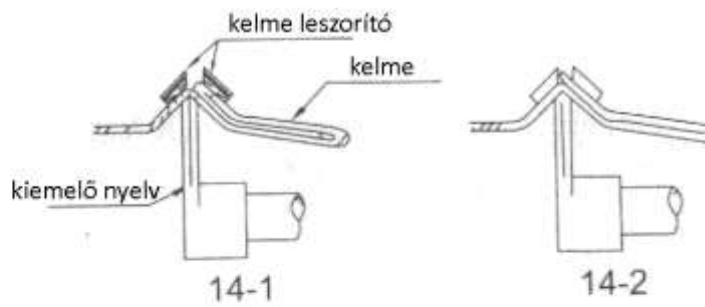

14-1

14-2

### 7. A fonalfék befűzése

Ügyeljünk arra, hogy a cérna a 2 fonalfék tányér között fusson.

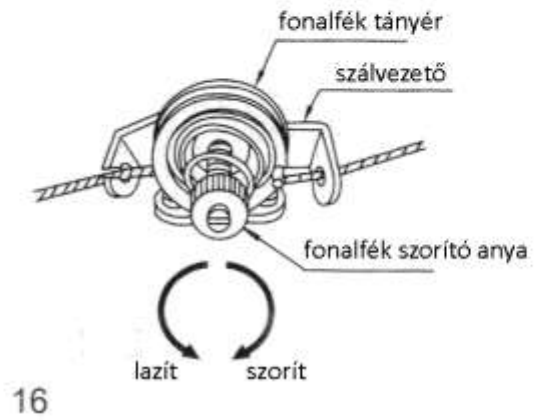

16

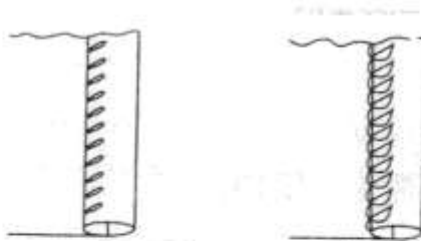

15

**Szál feszeség beállítása** a 15. ábra szerint.

# ALKATRÉSZ KATALÓGUS

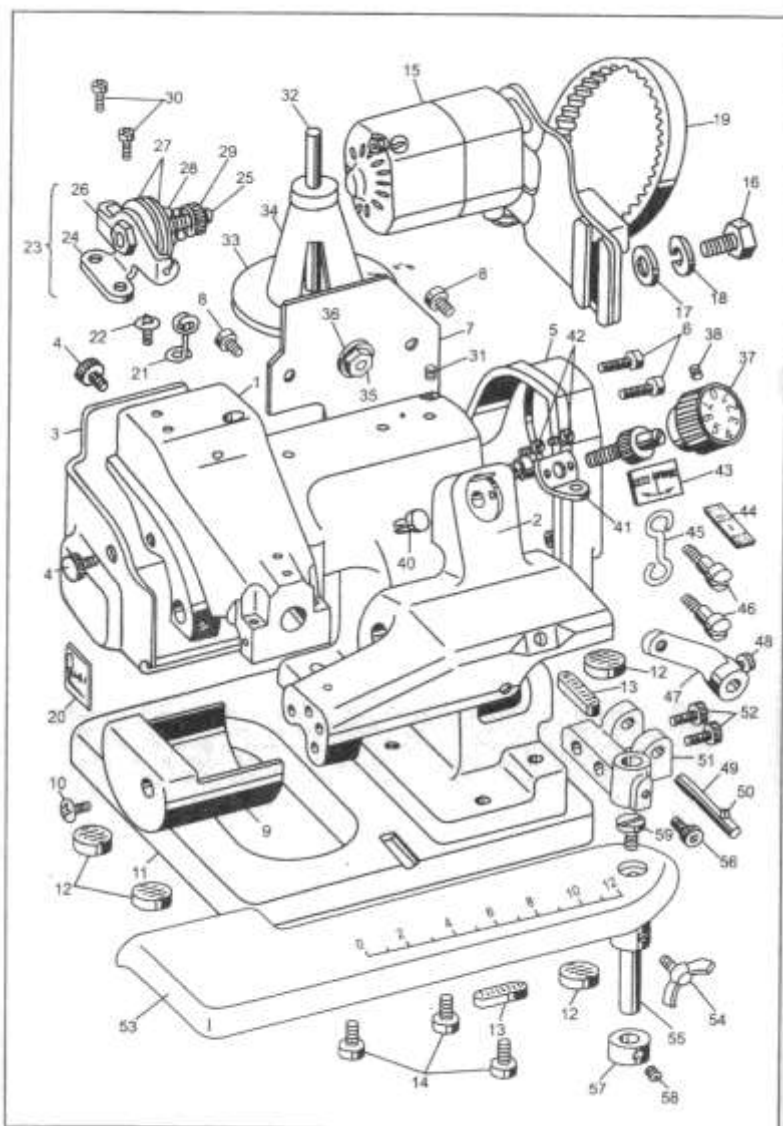

Ref Nos.	Parts No.	Description.
1	21001	Machine Frame
2	21002	Cylinder Bed
3	21003	Arm Side Cover
4	21004	Arm Side Cover Clamp Screw
5	21005	Pulley Cover
6	0144016	Pulley Cover Set Screw
7	21006	Arm Rear Cover
8	0144008	Arm Rear Cover Set Screw
9	21007	End Cover
10	0174008	End Cover Set Screw
11	S-21008-G	Machine Base with Rubber Cushion (Moss-Green)
11	S-21008-R	Machine Base with Rubber Cushion (Wine-Red)
12	21009	Rubber Cushion(A)
13	21010	Rubber Cushion(B)
14	0186016	Machine Base Clamp Screw
15	10109-A	Motor
16	B-005	Motor Bracket Set Screw
17	B-006	Motor Bracket Spring Washer
18	B-007	Motor Bracket Spring Washer
19	21101	Motor Belt
20	10131	Needle System Label (L.WX6T)
21	4135	Thread Guide (Pig Tail)
22	0144008	Thread Guide Set Screw
23	S-21095	Thread Tension Assembly (Ref.Nos.24-29)
24	21095	Thread Tension Bracket
25	21096	Thread Tension Post
26	4070	Thread Tension Post Nut
27	5190-A	Thread Tension Disc
28	79-B	Thread Tension Spring
29	83	Thread Tension Nut
30	0144008	Thread Tension Bracket Set Screw
31	0048006	Thread Guide Stud Set Screw
32	21093	Thread Stand
33	21094	Thread Stand Base
34	AC-101	Plastic Cap
35	11145	Thread Stand Nut
36	10543	Thread Stand Washer
37	S-10513-G	Disc Regulator (Moss-Green)
37	S-10513-R	Disc Regulator (Wine-Red)
38	6074	Disc Regulator Set Screw
39	10514	Disc Regulating Dial Screw
40	10516	Disc Regulating Dial Screw Prop
41	10515-A	Disc Regulating Plate Spring
42	8339	Disc Regulating Plate Spring Set Screw
43	21068	Disc Regulating Indicating Label
44	21037	Skip Stitch Label
45	10076-A	Cylinder Bed Connecting Hook
46	21085	Cylinder Bed Connecting Hook Screw
47	21083	Knee Lifter Crank
48	0216016	Knee Lifter Crank Set Screw
49	21084	Knee Lifter Shaft
50	10074	Knee Lifter Shaft Spring Pin
51	21082	Work Plate Bracket
52	0216016	Work Plate Bracket Set Screw
53	21081	Work Plate
54	10085	Work Plate Wing Screw
55	10082	Work Plate Shaft
56	0216012	Work Plate Shaft Set Screw
57	21023	Work Plate Shaft Collar
58	0096006	Work Plate Shaft Collar Set Screw
59	10083	Work Plate Screwed Cap

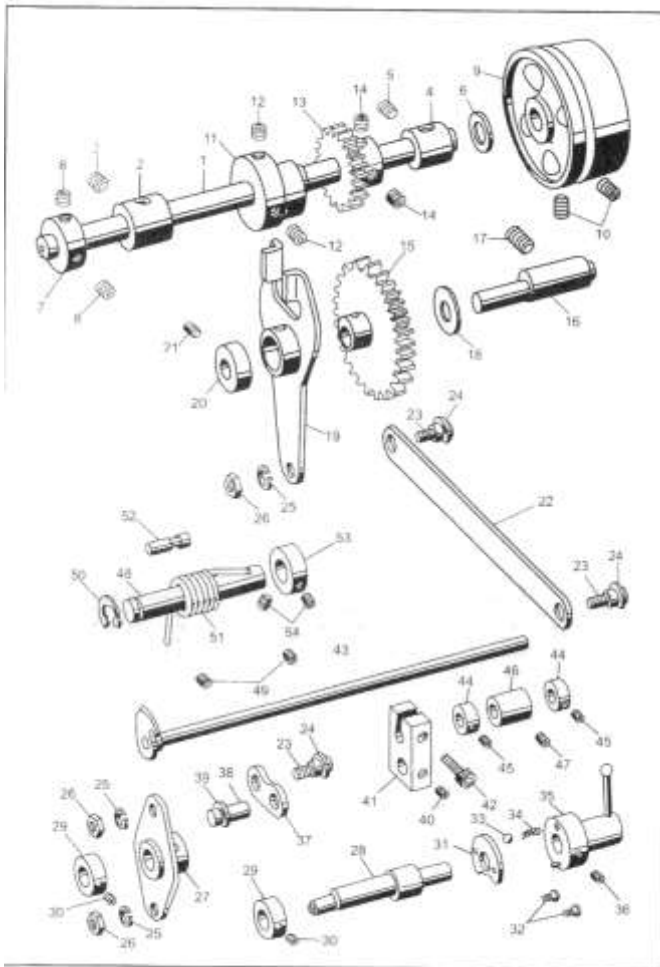

Ref No.	Parts No.	Description.
1	21012	Main Shaft
2	21013	Main Shaft Bushing (Front)
3	0096010	Main Shaft Bushing Set Screw
4	21014	Main Shaft Bushing (Rear)
5	0096010	Main Shaft Bushing Set Screw
6	21013	Main Shaft Thrust Washer
7	21016	Main Shaft Collar
8	0096006	Main Shaft Collar Set Screw
9	21017-C	Pulley (Moss-Green)
9	21017-R	Pulley (Wire-Rod)
10	0096014	Pulley Set Screw
11	21019	Eccentric Bushing
12	0096008	Eccentric Bushing Set Screw
13	21019	Main Shaft Gear (Small)
14	0096006	Main Shaft Gear Set Screw
15	21020	Skip Stitch Gear (Large)
16	21021	Skip Stitch Gear Eccentric Shaft
17	0096010	Skip Stitch Gear Eccentric Shaft Set Screw
18	21015	Skip Stitch Gear Eccentric Shaft Thrust Washer
19	21022	Skip Stitch Gear Eccentric Shaft Fork
20	21021	Skip Stitch Gear Eccentric Shaft Collar
21	0096006	Skip Stitch Gear Eccentric Shaft Collar Set Screw
22	21024	Connecting Link (Long)
23	21025	Connecting Link/Rod Holding Screw
24	10060	Connecting Link/Rod Holding Screw Snap Ring
25	10027	Connecting Link/Rod Holding Screw Spring Washer
26	17202	Connecting Link/Rod Holding Screw Nut
27	21026	Connecting Rod
28	21027	Skip Stitch Eccentric Shaft
29	21023	Skip Stitch Eccentric Shaft Collar
30	0096006	Skip Stitch Eccentric Shaft Collar Set Screw
31	21028	Skip Stitch Lever Plate
32	0124008	Skip Stitch Lever Plate Set Screw
33	4010	Skip Stitch Lever Plate Ball
34	10052	Skip Stitch Lever Plate Spring
35	S-21029	Skip Stitch Lever
36	0096010	Skip Stitch Lever Set Screw
37	21031	Connecting Link (Short)
38	21032	Connecting Link Holding Pin
39	10060	Connecting Link Holding Pin Snap Ring
40	0094004	Connecting Link Holding Pin Set Screw
41	21033	Connecting Block
42	0214012	Connecting Block Set Screw
43	S-21034	Ridge Forming Disc Shaft Assembly
44	21036	Ridge Forming Disc Shaft Collar
45	0094004	Ridge Forming Disc Shaft Collar Set Screw
46	10517	Ridge Forming Disc Shaft Bushing
47	0094006	Ridge Forming Disc Shaft Bushing Set Screw
48	21009	Cylinder Bed Shaft
49	0096006	Cylinder Bed Shaft Set Screw
50	19117	Cylinder Bed Shaft Snap Ring
51	21070	Cylinder Bed Shaft Spring
52	21071-A	Cylinder Bed Shaft Spring Pin
53	21016	Cylinder Bed Shaft Collar
54	0096006	Cylinder Bed Shaft Collar Set Screw

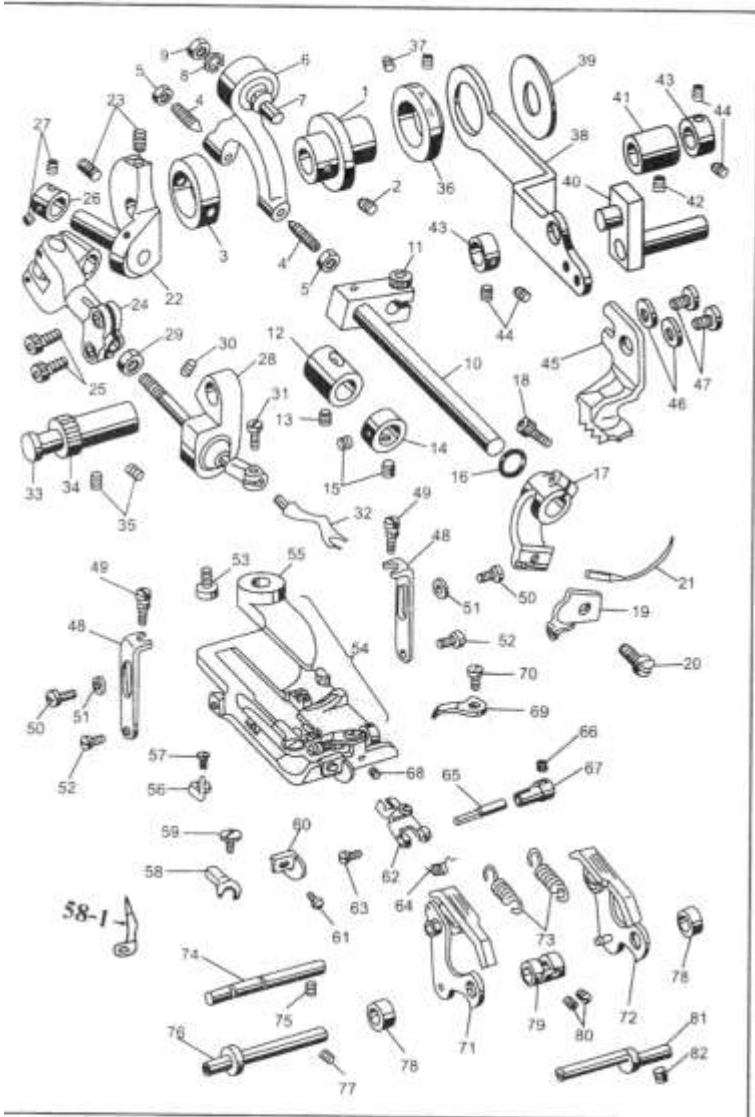

Ref.Nos.	Parts No.	Description
1	21038	Eccentric Bushing
2	0085010	Eccentric Bushing Set Screw
3	21046	Needle Yoke Ring
4	21047	Needle Yoke Center Screw
5	21048	Needle Yoke Center Screw Nut
6	S-21049-A	Needle Yoke & Ball Joint
7	21052-B	Needle Yoke Eccentric Pin
8	8179	Needle Yoke Eccentric Pin Spring Washer
9	C-10022	Needle Yoke Eccentric Pin Nut
10	S-21053	Needle Carrier Shaft Crank
11	0214016	Needle Carrier Shaft Crank Set Screw
12	21055	Needle Carrier Shaft Bushing
13	0094006	Needle Carrier Shaft Bushing Set Screw
14	21016	Needle Carrier Shaft Collar
15	0096006	Needle Carrier Shaft Collar Set Screw
16	19034	Needle Carrier Shaft "O" Ring
17	21056	Needle Carrier
18	0215016	Needle Carrier Clamp Screw
19	4025 A	Needle Clamp
20	121	Needle Clamp Set Screw
21	4181	Needle (LWx6T)
22	S-21057	Looper Drive Crank & Pin
23	0096014	Looper Drive Crank Set Screw
24	S-21059	Looper Yoke With Joint & Pin
25	0214012	Looper Yoke Set Screw
26	17037	Looper Yoke Pin Collar
27	17146	Looper Yoke Pin Collar Set Screw
28	S-21062-A	Looper Carrier Assembly
29	21048	Looper Carrier Nut
30	0096006	Looper Ball Joint Clamp Screw
31	4040	Looper Clamp Screw
32	4039	Looper
33	21064	Looper Ball Joint Pin
34	21065	Looper Ball Joint Eccentric Sleeve
35	0046008	Looper Ball Joint Eccentric Sleeve Set Screw
36	21039-A	Stitch Regulating Eccentric
37	0094006	Stitch Regulating Eccentric Set Screw
38	21040	Feed Lever
39	21041	Feed Lever Thrust Washer
40	S-21042-A	Feed Lever Crank
41	10517	Feed Lever Crank Bushing
42	0094006	Feed Lever Crank Bushing Set Screw
43	21045	Feed Lever Crank Collar
44	0094004	Feed Lever Crank Collar Set Screw
45	4047-C	Feed Dog
46	2528	Feed Dog Washer
47	4048-A	Feed Dog Set Screw
48	4061-A	Presser Foot Bracket
49	21066	Presser Foot Bracket Adjusting Screw
50	0144008	Presser Foot Bracket Holding Screw
51	1158	Presser Foot Bracket Holding Screw Washer
52	4186	Presser Foot Holding Screw
53	21067	Presser Foot Clamp Screw
54	PF100	Presser Foot Assembly (Ref Nos.54-69)

For Needle System LWx6T  
(Re-LWx5T refer to Page 4)

Ref.Nos.	Parts No.	Description
55	4049-B	Plain Presser Foot
56	4048-A	Chaining Finger
57	4185	Chaining Finger Set Screw
58	11563	Needle Guide
58-1	11563-A	Stitch Stabilizing Guide
59	4052-A	Needle Guide Set Screw
60	4059	Edge Guide
61	4185	Edge Guide Set Screw
62	4055-CAS	Cloth Retainer
63	4185	Cloth Retainer Screw
64	4056	Cloth Retainer Spring
65	4054	Cloth Retainer Eccentric Stud
66	4183	Cloth Retainer Eccentric Stud Set Screw
67	4053	Cloth Retainer Eccentric Stud Bushing
68	130-B	Cloth Retainer Eccentric Stud Bushing Set Screw
69	4057-B	Cloth Retainer Stopper
70	4182	Cloth Retainer Stopper Set Screw
71	S-21072	Feed Plate Assembly(Left)
72	S-21073	Feed Plate Assembly(Right)
73	21078	Feed Plate Bracket Spring
74	21079	Feed Plate Bracket Spring Pin
75	0094006	Feed Plate Bracket Spring Pin Set Screw
76	21075	Feed Plate Bracket Shaft
77	0094006	Feed Plate Bracket Shaft Set Screw
78	21076	Feed Plate Bracket Shaft Spacer
79	21077	Feed Plate Bracket Shaft Thrust Collar
80	0094004	Feed Plate Bracket Shaft Thrust Collar Set Screw
81	21080	Feed Plate Bracket Eccentric Shaft
82	0094006	Feed Plate Bracket Eccentric Shaft Set Screw

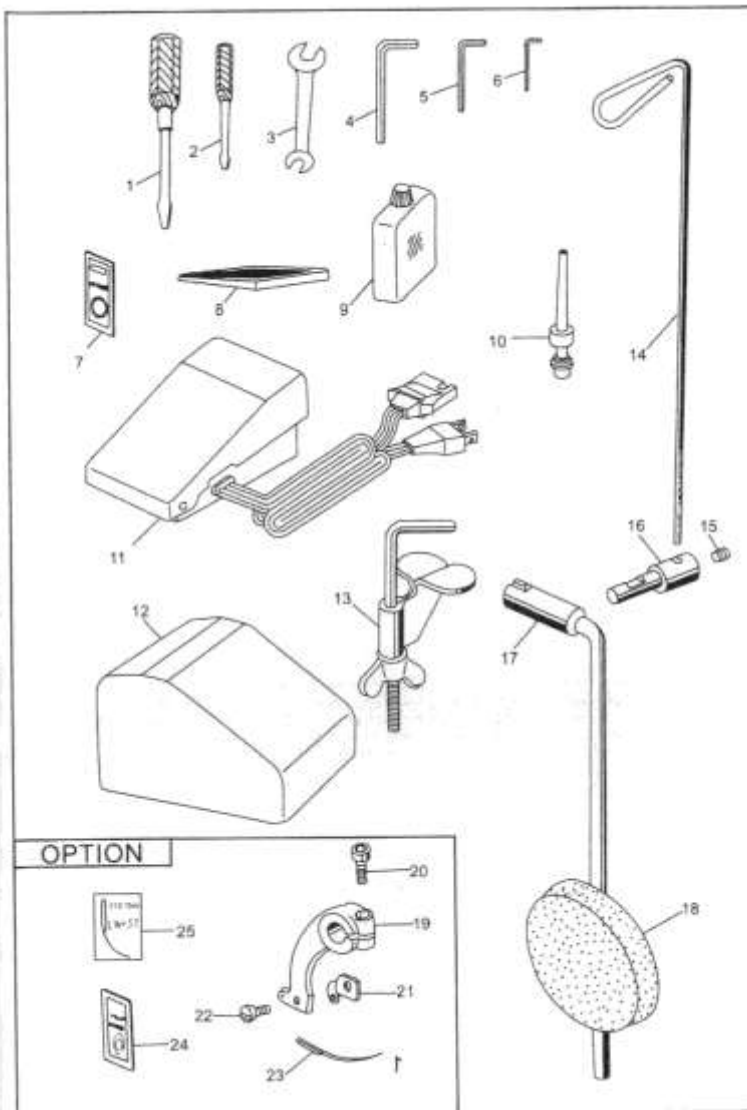

Ref.Nos.	Parts No.	Description.
1	AC-02	Screw Driver
2	AC-03	Screw Driver
3	AC-104	Spanner
4	AC-102	Wrench(5m/m)
5	AC-06	Wrench(3m/m)
6	C-16003	Wrench(2m/m)
7	4181	Needle(LWx6T) (3pcs)
8	AC-09	Tweezers
9	AC-05A	Oil
10	AC-04A	Oiler
11	10110-A	Controller Pedal
12	C-10A	Vinyl Cover
13	S-21097	Machine Clamp Assembly
14	21103	Thread Guide
15	0044004	Thread Guide Set Screw
16	21092	Thread Guide Stud
17	S-21086	Knee Press Rod & Sleeve
18	S-21088	Knee Press Pad Assembly

OPTIONAL PARTS for Needle system LWxST

19	17026	Needle Carrier
20	17144	Needle Carrier Clamp Screw
21	17027	Needle Clamp
22	17145	Needle Clamp Set Screw
23	17028	Needle (LWx5T)
24	17028	Needle (LWx5T) (3 pcs)
25	21102	Needle System Lable (LWx5T)