

Operator's Guide SINGER*

457U105, 457U125, 457U135, 457U140 Machines

LUBRICATION

FOR THE AUTOMATIC LUBRICATION
USE SINGER "TYPE C" OIL ONLY

Check oil flow in window when
machine is running.

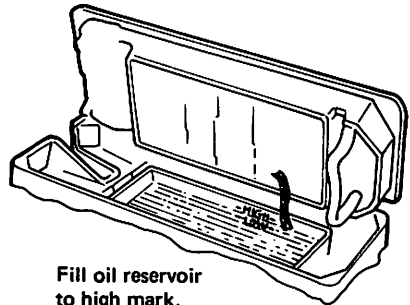
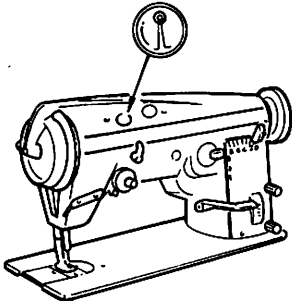

Fill oil reservoir
to high mark.
Check daily.

Check oil flow to hook by
holding a small piece of paper
under the hook while machine
is running. After 15 seconds,
the paper should show an
oil pattern of approx
1/32 inch (0.8mm).

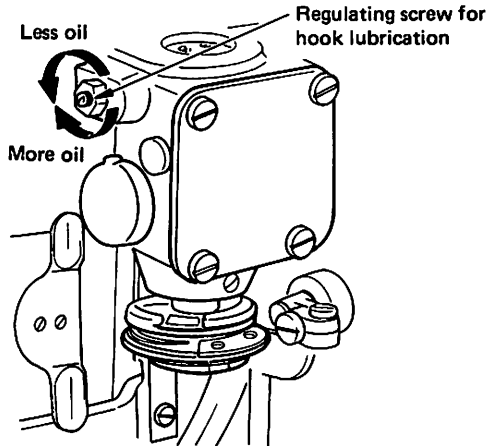

SPEED

The maximum speeds recommended for Machines of Class 457U are 5000 RPM (4500 RPM for 457U140), however, for the first 150 hours machines should be run at least 500 RPM below maximum recommended speeds.

NEEDLES

Use Singer needles

Catalog 1906
(chromium finished)

Machine 457U140 only
Catalog 8752
(chromium finished)

—In sizes determined by
size of thread and type
of material being sewn.

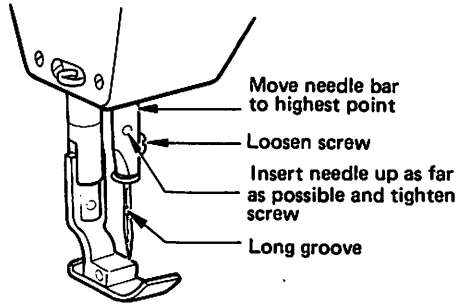

SETTING THE NEEDLE

UPPER THREAD

1. Before threading, any remains of thread must be removed from the rotary take-up.

CAUTION: Be careful to avoid injury from thread cutter ❶.

2. Thread only with the needle bar in highest position.

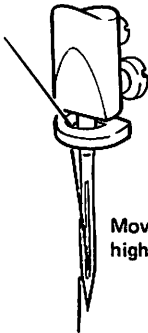

Move needle bar to highest point

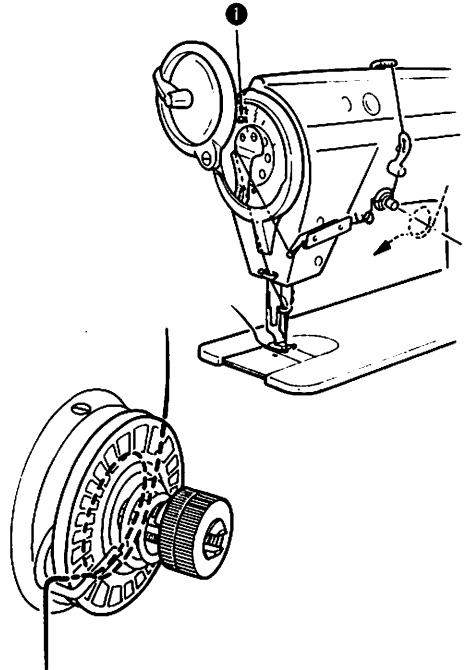

BOBBIN REMOVAL AND REPLACEMENT

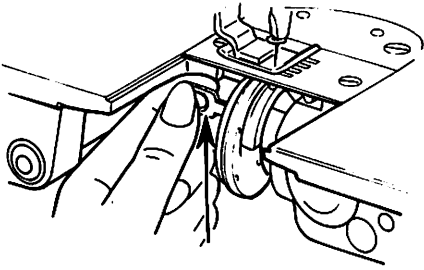

REMOVAL

1. Open latch
2. Hold latch and pull bobbin case from hook
3. Release latch
4. Bobbin drops out

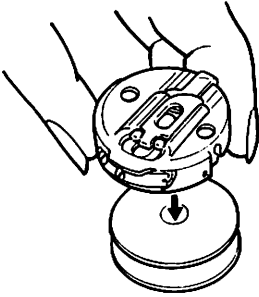

REPLACEMENT

5. Holding latch, replace bobbin case on stud
6. Release latch
7. Press back until latch catches groove in stud

BOBBIN WINDER

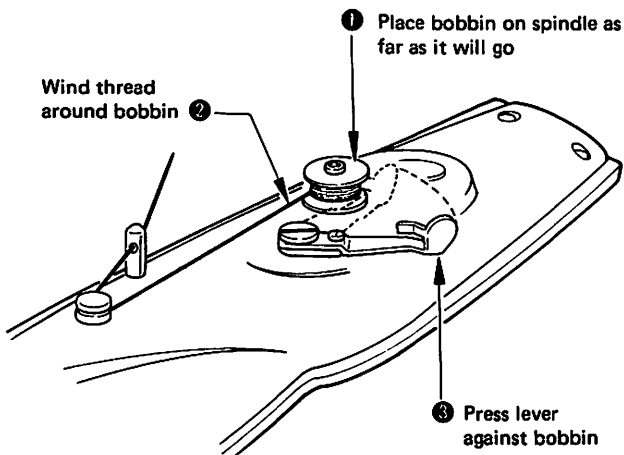

THREADING BOBBIN CASE

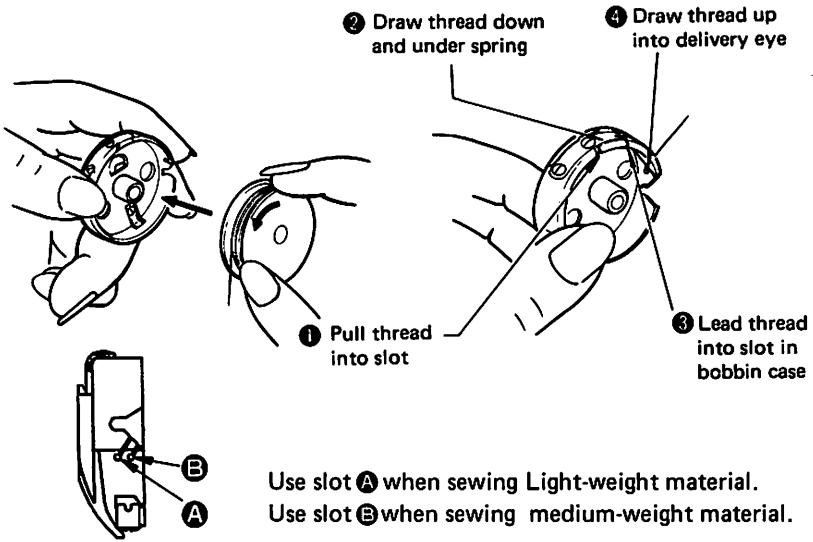

THREAD TENSIONS

BOBBIN THREAD

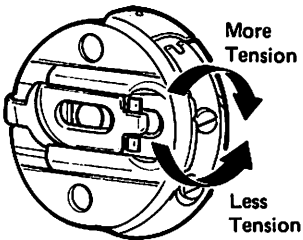

Tension on threads should be as light as possible, while still sufficient to set stitch correctly in material.

NEEDLE THREAD

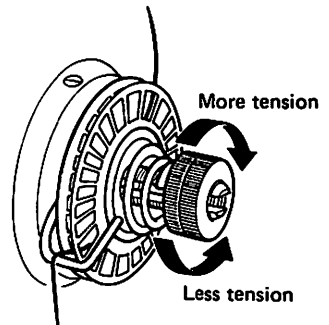

Regulate needle thread tension only when presser foot is down.

STITCH LENGTH REGULATION

457U105, 457U125, 457U135 MACHINES

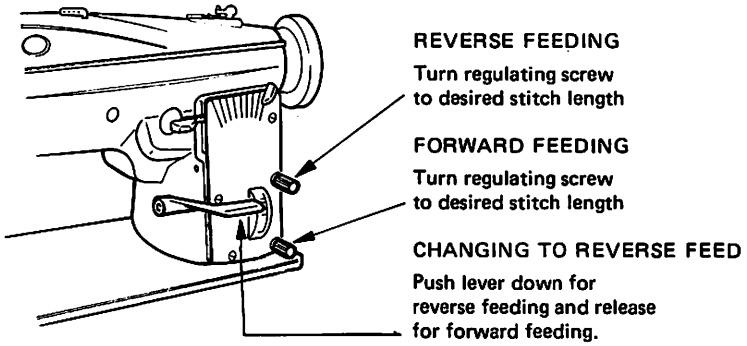

STITCH LENGTH REGULATION

457U140 MACHINE

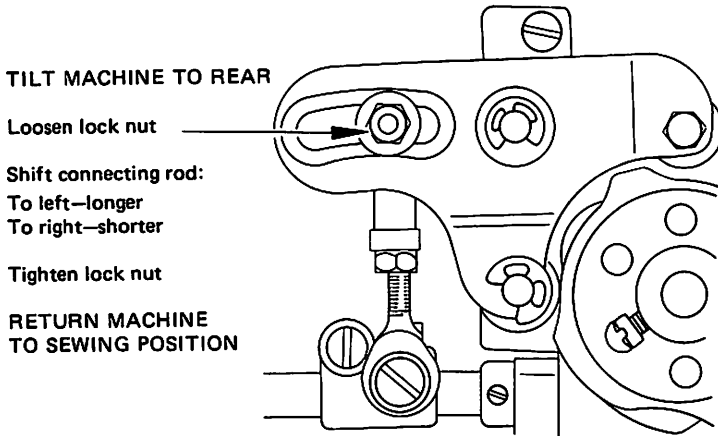

ZIG-ZAG STITCH SETTING 457U105 MACHINE

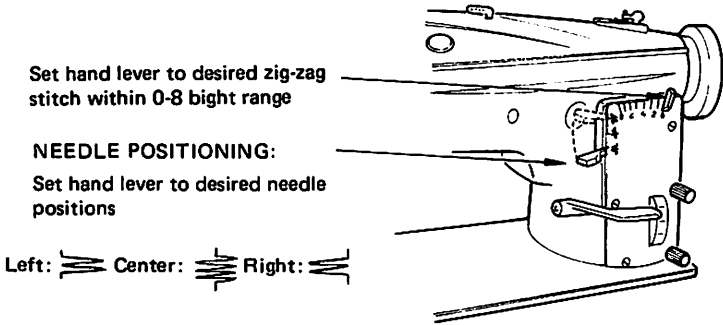

ZIG-ZAG STITCH SETTING 457U125, 457U135, 457U140 MACHINES

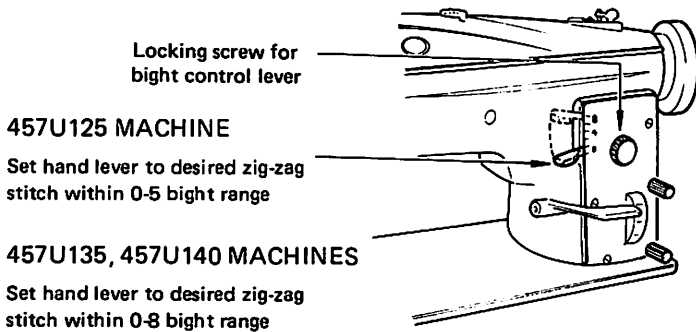

PRESSER FOOT PRESSURE

The pressure on the material should be as light as possible, while still sufficient to ensure correct feeding.

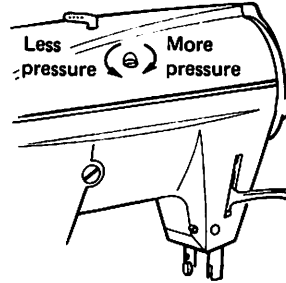

CLEANING

Clean out any lint or other waste around the hook, between the feed rows on the underside of the throat plate and in the hook area of the oil pan.

* A Trademark of THE SINGER COMPANY
Copyright ©1987 SINGER SEWING MACHINE COMPANY
All Rights Reserved Throughout The World

Form U3150 (Rev. 990)
Part No. 543182-002 (Rev. 2)
Printed in Japan